

Wirelessly Controlled Irrigation System

Zain-Aldeen S. A.Rhman
Dept. of Electrical Engineering
University of Basrah
Basrah, Iraq
aszain123@gmail.com

Ramzy S. Ali
Dept. of Electrical Engineering
University of Basrah
Basrah, Iraq
rsalwaily@ieee.org

Basil H. Jasim
Dept. of Electrical Engineering
University of Basrah
Basrah, Iraq
hanbas632@gmail.com

Abstract— In the city of Basrah, there is an urgent need to use the water for irrigation process more efficiently for many reasons: one of them, the high temperature in long summer season and the other is the lack of sources fresh water sources. In this work, a smart irrigation system based wireless sensor networks (WSNs) is implemented. This system consists of the main unit that represented by an Arduino Uno board which include an ATmega328 microcontroller, different sensors as moisture sensors, temperature sensors, humidity sensors, XBee modules and solenoid valve. Zigbee technology is used in this project for implementing wireless technology. This system has two modes one manual mode, the other is a smart mode. The set points must be changed manually according to the specified season to satisfy the given conditions for the property irrigation, and the smart operation of the system will be according to these set points.

Index Terms— Smart irrigation, WSN, Arduino Uno, Moisture.

I. INTRODUCTION

A smart irrigation system is a system that gives water to the plants where water is needed with the required amounts only. When compared with the conventional irrigation systems that work on the principle of timer-based irrigation that give water to the plants where water is needed without the required amounts. In 2007, G. Vellidis, *et. al.* [1] presented the use of wireless sensors in the agriculture, this project shed light on the collection of information from rain gauges, soil moisture sensors and other devices, control equipment (start pumps, close gates, etc.) and how these motes will communicate with each other by using a wireless technology. In 2008, Kim, *et. al.* [2] proposed an efficient water

management based on distributed wireless sensor network for cropping systems. This system was electronically controlled by a programming logic controller that updates geo-referenced location of sprinkler from differential global positioning system and wirelessly communicates with a computer at the base station. In 2009, Luis Ruiz-Garcia, *et. al.* [3] presented a review of wireless sensor technologies and applications in agriculture and food industry. The project focus on WSN and RFID (Radio Frequency Identification), presenting the different systems available, including ZigBee based WSN. In 2010, Xiu-hong Li , *et. al.* [4] designed a monitoring system for vegetable greenhouses based on a wireless sensor network. The complete system architecture includes a group of sensor nodes, the base station, and an internet data center. A GSM (global system for mobile communications)-short-message-based interface is developed for sending real-time beyond some pre-defined threshold. In 2011, Ragheid Atta, *et. al.* [5] proposed a smart irrigation system for wheat in Saudi Arabia using wireless sensors network technology. The system consists of real-time sensor data acquisition, a decision module for calculating the optimal quantity and spread pattern for a fertilizer and an output module to regulate the fertilizer application rate. The system was proven to be cheap, reliable and simple to use. In 2012, V. Ramya, *et. al.* [6] proposed an embedded System for automatic irrigation of the cardamom field using Xbee-PRO technology this wireless system supports the cardamom field which has both plain and slope areas. This system has software for real-time in-field sensing and control of an irrigation system and provides uniform and required level of water for both plain and slope areas and therefore it avoids the water

overflow at the slope areas which saves the plant and also water. In 2013, V.Divya, *et. al.* [7] proposed smart irrigation technique using vocal commands. In this system, the farmer just needs to call a fixed number and utter the control commands through his phone. The control system at the field involves a PIC microcontroller interfaced with GSM modem to receive a command from the farmer and a voice recognition unit which decodes it. The motor is turned on/off according to the decoded commands by the controller. In 2014, Joaquin G., *et. al.* [8] suggested an automated irrigation system to optimize water use for agricultural crops. The system has a distributed wireless network of soil moisture and temperature sensors placed in the root zone of the plants. It is also has a gateway unit handles sensor information, triggers actuators, and transmits data to a web applications. The system was tested in a sage crop field for 136 days and water savings up to 90% compared with traditional irrigation systems.

In this paper, a smart irrigation system based on WSNs, is implemented, the principle operation of this system depends on the monitored parameters that include the soil moisture, the surrounding relative humidity and air temperature.

Agricultural irrigation is very important in crop production. Therefore, the main issues of the research hide in improve the economical, saving freshwater resources, healthy and the rest for the costumer. By using a smart system depending on WSN agricultural field the irrigation will be efficient by determining the time and the local of plants that need for irrigation and there will not dissipate water in the irrigation process. The WSN eliminates the need to hardwire sensor stations across the field and reduces installation and maintenance costs.

II. THE SMART IRRIGATION

Irrigation is most important in crop production in the agriculture areas, the major disquiet with irrigation activities in agriculture areas is the efficient water use applications and management. Due to the rapid advances in wireless communication and information technologies it is now possible to use various levels of smartness in agriculture fields. In this

work, a smart system supporting by wireless technology is desired and implemented for irrigation managements. These smart irrigation systems are ones that can interrelate intelligently to provide comfort and safe living. The smart irrigation needs tools and technologies that can improve production efficiency, product quality, postharvest operations, and reduce their environmental impact. A definition the smart irrigation may be the following: the technique of applying the optimal amount of water at the right location and the best time to enhance production and improve the quality for plants [9].

III. SYSTEM DESCRIPTION

In this system real-time monitoring parameters for temperature, humidity in the atmosphere and content of moisture in the soil are the important factors for obtaining high-quality for system operation. To implement this system the field must be divided to numbers of zones depending on many factors as size of fields, nature of soil, nature of plants, nature of field, mechanical of the irrigation, and the season. Each zone contains at least one node; these nodes are the sensor units (SUs) and must communicate with a central unit that called a base station unit (BSU). The system is planned to be implemented using distributed wireless sensor network (WSN) that utilizes Zigbee technology. According to this wireless technology, the distance between the BSU and the SUs in practical experiments is found about 70 m with consideration the obstacles availability (as trees)) and 100 m without obstacles. The sensors that the system needed are soil moisture sensors, temperature and humidity sensor (DHT-22). The Arduino Uno board (with ATmega328) that will be the brain for the system, the actuator that is a solenoid valve and XBee modules for implementing the wireless technology in this system. The system consists from BSU and many SUs as shown in Fig. 1.

In the SUs, the humidity and temperature sensors should be in place that ensure the suitable reading for the field humidity and the air temperature. While the soil moisture sensor must be in the proper location in the soil field as near the plant roots for achieving an accurate measurements for the soil moisture.

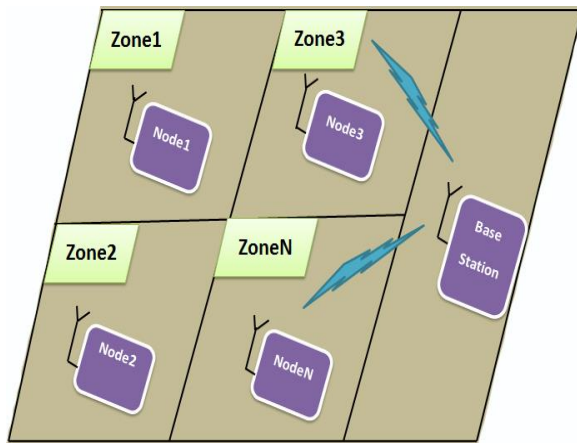

Fig. 1 Proposed system diagram.

The BSU will be the main control unit for the whole system and the nodes respond to the base station what its need and execute its instructions. The area that can be covered by a SU is determined by many factors as the frame nature, plants nature, the season, the frame geographical location, and the water flow rate that determined by the solenoid valve.

IV. HARDWARE DESCRIPTION

The system hardware consists of a single BSU and several SUs. The details are as follows:

A. The Base Station Unit (BSU)

The base station plays a key role in the designed system. The hardware of base station consists of an Arduino Uno board, liquid crystal display (LCD), which is used for monitoring the required parameters and XBee modules used to communicate wirelessly between the BSU and SUs. Fig. 2(a), shows the BSU schematic diagram and Fig. 2(b), shows the internal construction of a prototype BSU that used for implementing the system.

1) The Arduino Uno Board

Arduino is an open-source microcontroller that uses ATmega328, an Atmel AVR processor which can be programmed by the computer in C language via Universal Serial Bus (USB) port.

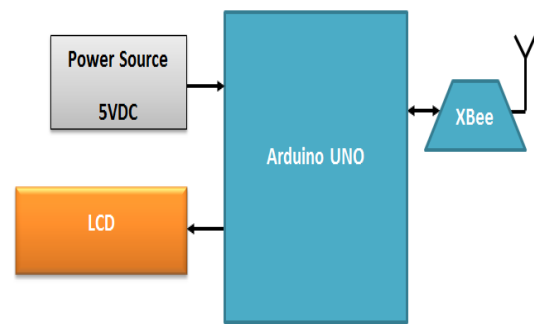

(a)



(b)

Fig. 2 Base station unit. (a) Schematic diagram. (b) Internal construction.

Arduino also has on-board 6 analog pins and 13 digital pins for input and output operations, supporting serial peripheral interface (SPI) and Inter-integrated circuit (IIC) which can be used to interface with other devices [10]. Fig. 3, shows the Arduino Uno board.

2) LCD Interfacing

The LCD in the base station used for monitoring the state of nodes (on or off), current humidity for air, temperature of the field, and moisture content in the field soil. The LCD size 20*4 that use IIC serial bus is used in this system. The interfacing of the LCD to the Arduino Uno board shown in Fig. 4.

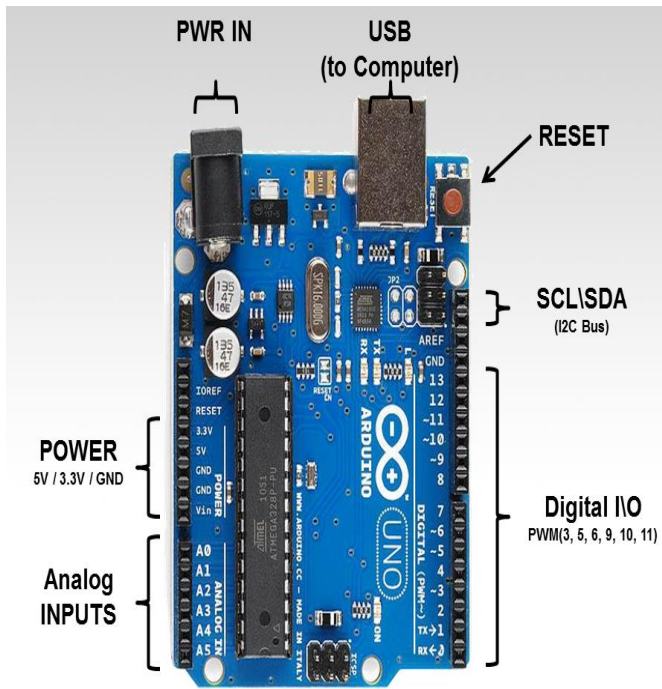

Fig. 3 Arduino UNO Board.

3) The XBee Module

In this work, the XBee modules are used for implementing Zigbee wireless communication technology in the system. The interfacing of the XBee to the Arduino Uno board is shown in Fig.5.

B. The Sensor Unit (SU)

The SUs are the system nodes that responsible for the measurements of humidity, temperature and moisture depending on the sensor content in the node. The DHT-22 sensor for sensing the humidity and the temperature and soil moisture sensor used for sensing the water content in the soil. Also, the SU supported with an Arduino Uno board for processing the signals from the sensors and an XBee to communicate wirelessly with BSU. Fig. 6, shows the schematic diagram of a system node and Fig. 7, shows the internal construction of a prototype node that used for implementing the system.

1) Humidity and Temperature Sensor Interfacing

It is a combined temperature and humidity sensor called DHT-22 used for sensing surrounding humidity and temperature. It's a capacitive humidity sensing.

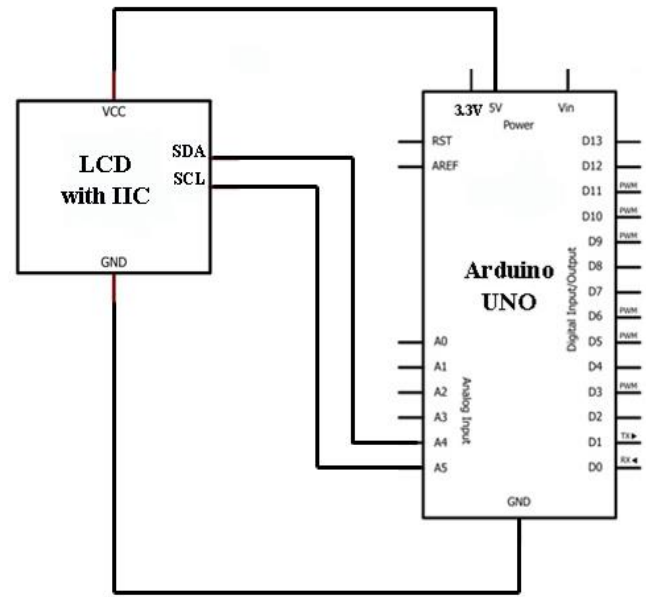

Fig. 4 Interfacing LCD with Arduino Uno board.

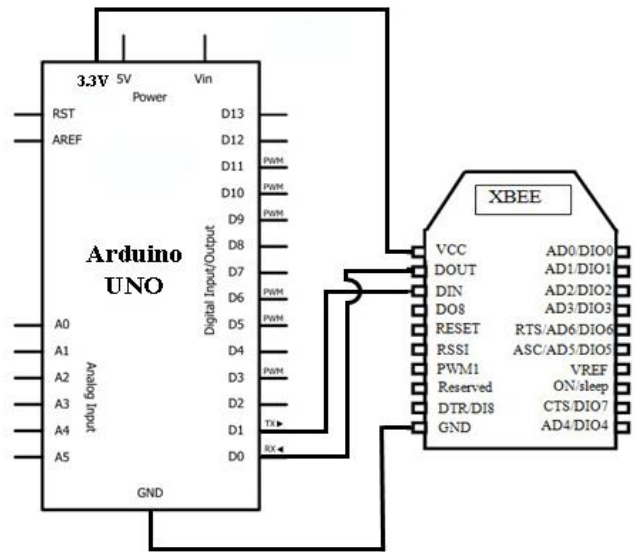

Fig. 5 Interfacing XBee with Arduino Uno board.

Application of a dedicated digital modules collection technology and the temperature and humidity sensing technology, to ensure that the product has high reliability and excellent long-term stability [11]. Fig. 8, shows the interfacing of DHT-22 sensor with the Arduino Uno board.

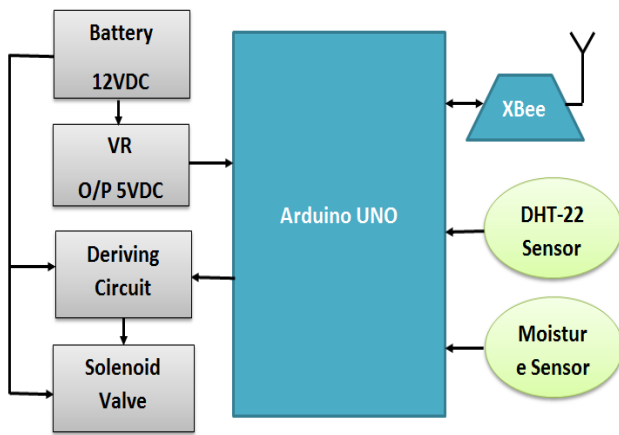

Fig. 6 The system node schematic diagram.

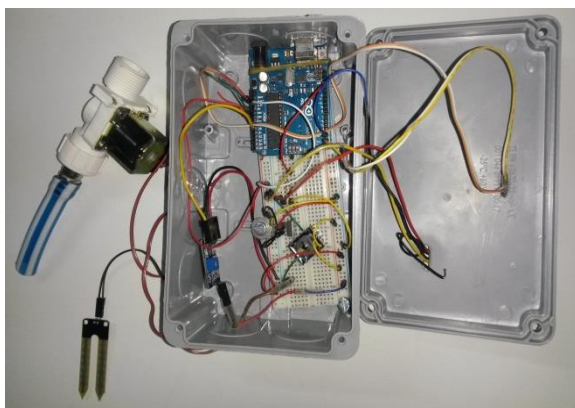

Fig. 7 The internal construction of the system prototype node.

2) The Soil Moisture Sensor

This sensor used for sensing the water content of the soil in the field. The moisture sensor has two probes and uses them to measure soil moisture in the soil by telling how well an electrical current is passed between the two probes [12]. Fig. 9(a), shows the soil moisture sensor and Fig. 9(b), shows interfacing the soil moisture sensor with the Arduino Uno board.

3) Solenoid Valve Interfacing

In this system a solenoid valve is used to be the actuator for controlling the water flow to start or stop the irrigation process according to the control signals that received from the microcontroller through the driving circuit in the SU. Fig. 10, shows the used driving circuit and Fig. 11, shows illustrates the driving circuit interfacing.

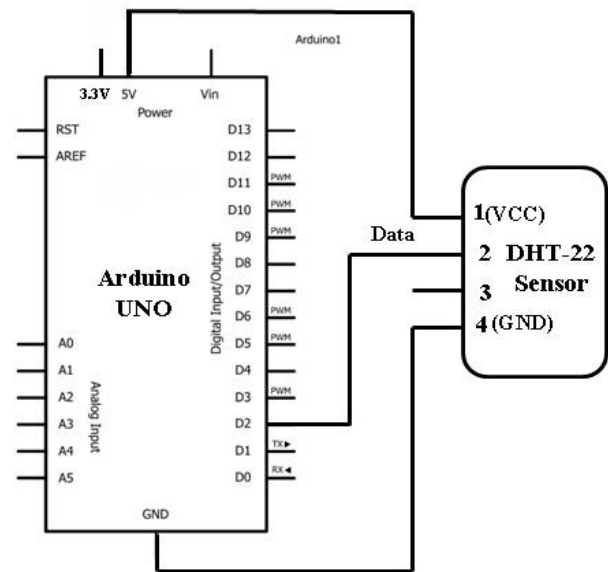
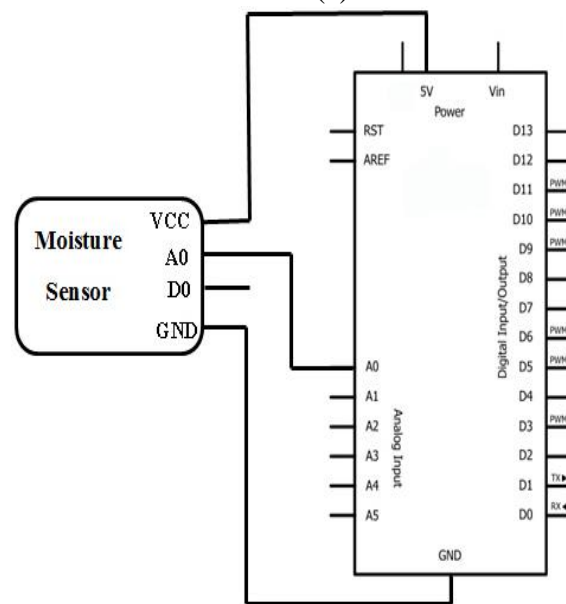

Fig. 8 Interfacing DHT-22 with Arduino Uno board.



(a)



(b)

Fig. 9 Interfacing the soil moisture sensor. (a) The sensor. (b) Interfacing schematic diagram.

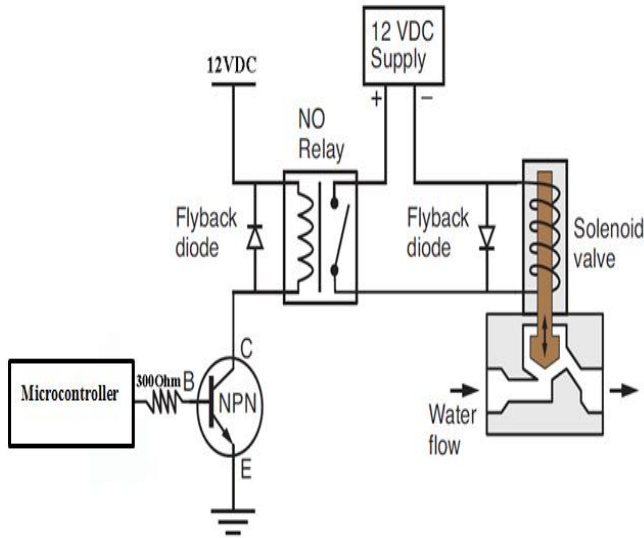

Fig. 10. The driving circuit.

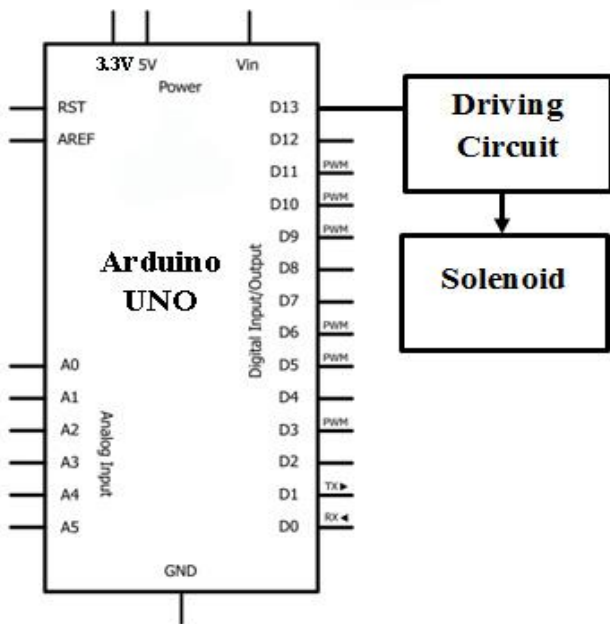

Fig. 11. Solenoid valve interfacing.

V. SOFTWARE DESCRIPTION

The software part contains the programming of Zigbee network, the system protocol using the Arduino Integrated Development Environment (IDE) with Matlab.

A. Zigbee Network

In this work, a simple point-to-multipoint topology is used. We achieved that by using X-CTU software that used for XBee module

configuration for building the wireless Zigbee network. In this simple network, all nodes are managed by a central node which called a base station or master or coordinator. Fig. 12, shows the base station configuration by using X-CTU software and Fig. 13, shows the node configuration by using X-CTU software.

B. The System Protocol

We can describe the system protocol as following, after power up, the base station Unit (BSU) sends addresses data to all SUs for getting the data. The SU responds according to its address from the BSU, if the SU address matches the BSU, it can evaluate the moisture, humidity and soil moisture data, then sends these data with its address to the BSU. The BSU checks the data according to the determined threshold values and sends the control signals to the required node to be the start or stop the irrigation. These threshold values should be chosen according to the plants water requirements with the environmental parameters. The data and the node state will be displayed by the LCD in the BSU. Fig. 14, shows flowchart of the BSU and Fig. 15, shows flow chart of the SU.

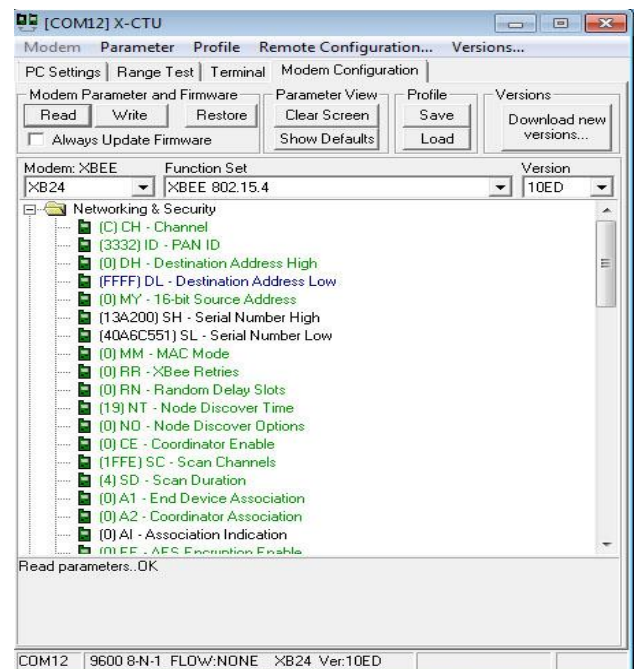

Fig. 12 The base station configuration by using X-CTU software.

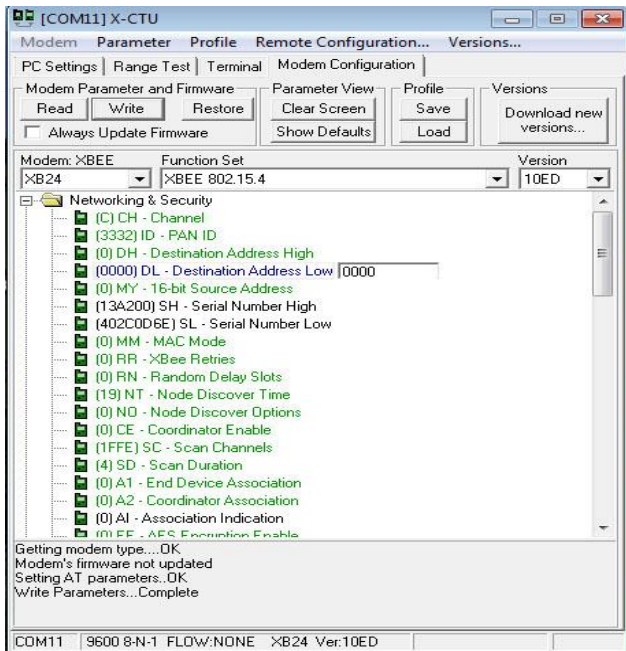

Fig. 13 The node configuration by using X-CTU software.

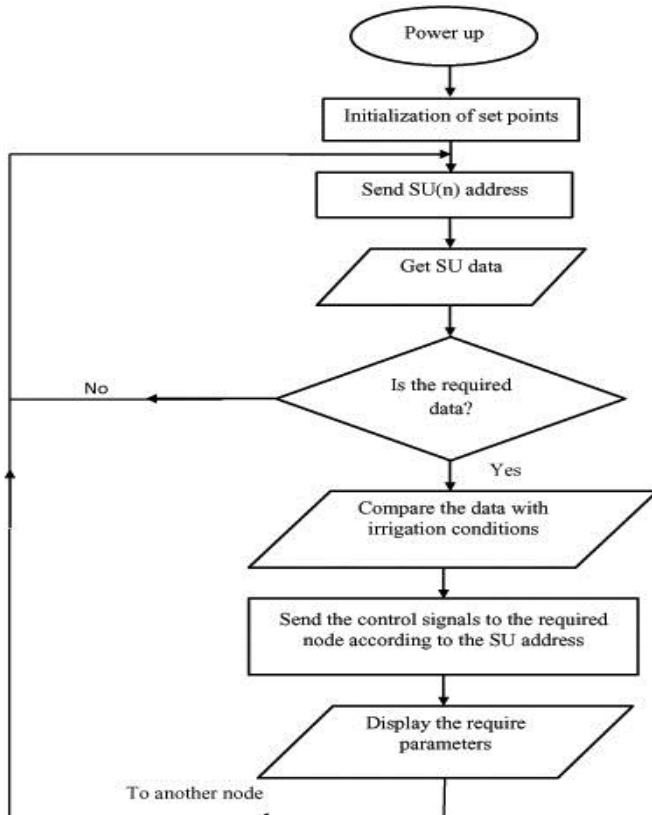

Fig. 14 BSU flowchart.

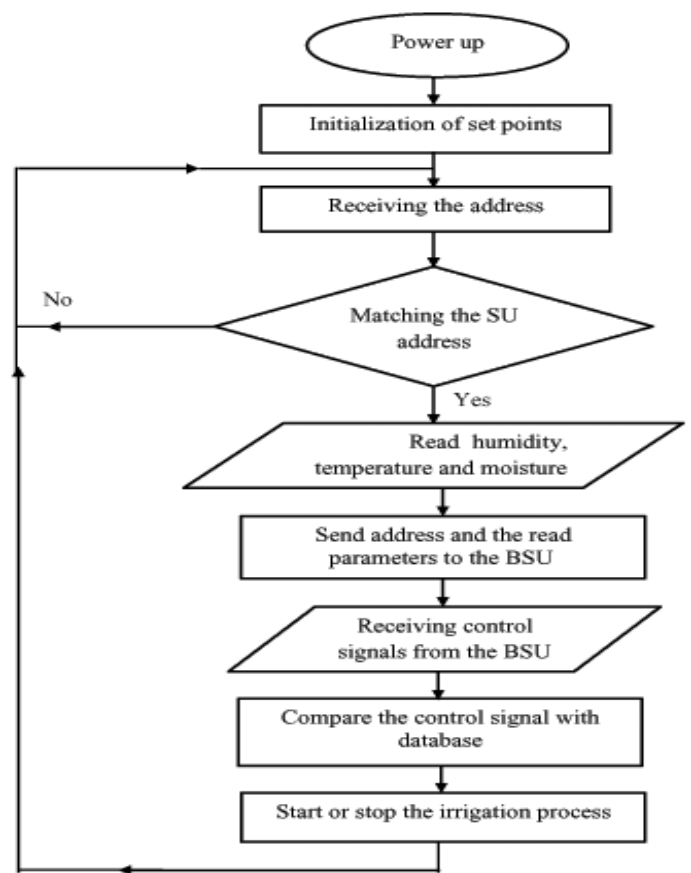

Fig. 15 SU flowchart.

C. Arduino IDE

The Arduino board which contents an Atmega328 microcontroller is programmed using IDE software that utilizes C language. The screenshot of the Arduino software can be seen in Fig. 16.

VI. RESULTS AND DISCUSSION

The proposed system was applied on anvil's plants and in actual field for measuring required data from agriculture field as soil moisture, surrounding humidity and air temperature.

A. An Anvil's Plants Test

This test is performed on the shade plants in the anvils as shown in Fig. 17. The LCD in the base station interfaces with the Arduino Uno to display the sensed values. These values represent the soil moisture from soil moisture sensor, the surrounding humidity and air temperature from the DHT-22 sensor and also displays the node address and the irrigation state run or stop.

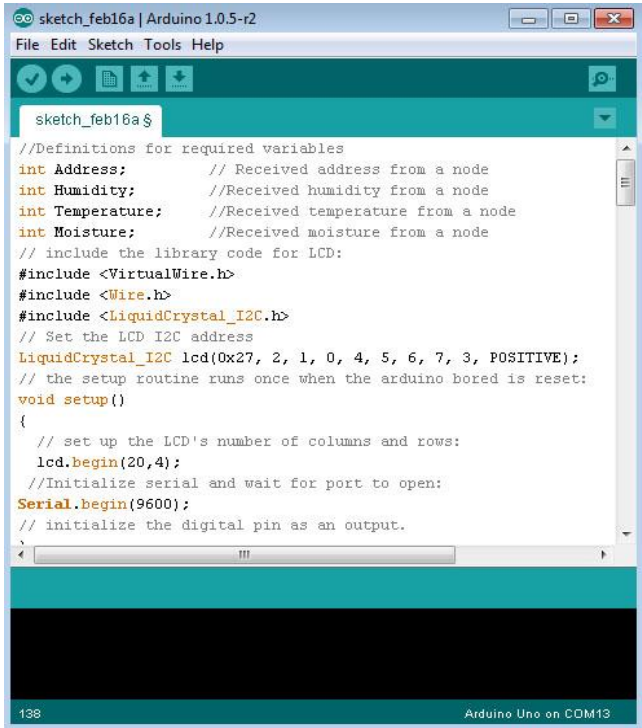

Fig.16 The Arduino software screenshot.



Fig. 17 System nodes in anvil's plants

Fig. 18, shows the LCD, which displays the required parameters for different states according to required threshold values of relative humidity, temperature, and soil moisture.

It can be seen from Fig.18 that the LCD shows the state of two nodes. Fig. 18(a) and Fig. 18(b), indicate that the parameters of the first node (the state of the node on/of, humidity, temperature, in the degree and the moisture). The parameters of the second node are shown in Fig. 18(c) and Fig. 18(d). Different temperature degrees are displays

(different Seasons), 40C and 28C in a and b, respectively.



(a)

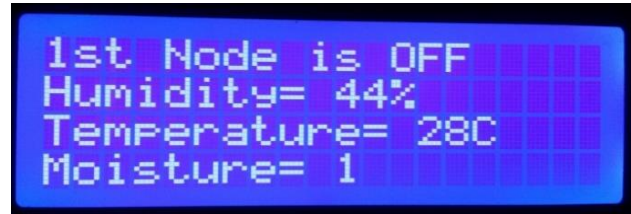

(b)



(c)

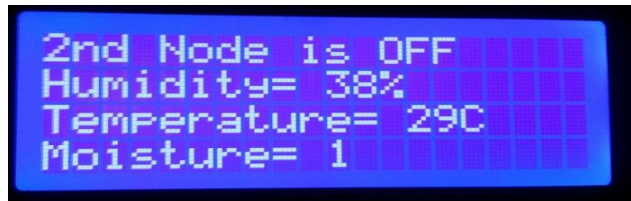

(d)

Fig. 18 displays the required system parameters.

The moisture sensor reading presented in a voltage form (0-5V), where 0 represents the percent of high relative soil moisture while 5 presents the percent of low relative moisture.

B. An Actual Field Test

An actual field test is shown in Fig. 19. The system is tested for 24 hours and the required parameters (the state of the node on/of, humidity, temperature, in degree and the moisture) are recorded for each node at each hour. It can be seen from Fig. 19, that the area of each node is 2mX2.5m. This area may become larger depends on the type of solenoid valve.

TABLE I

C. First Node Test

Table I, shows experimental results for the system test in the actual field for the first node. In this node, the test has been started at the ten o'clock AM and the soil moisture sensor is placed in a very dry soil. Therefore, the soil moisture sensor noted with 5V reading and according to the determined irrigation conditions (the soil moisture greater than 3V, the relative humidity less than 80%, and the temperature greater than 15C⁰) the node started the irrigation process.

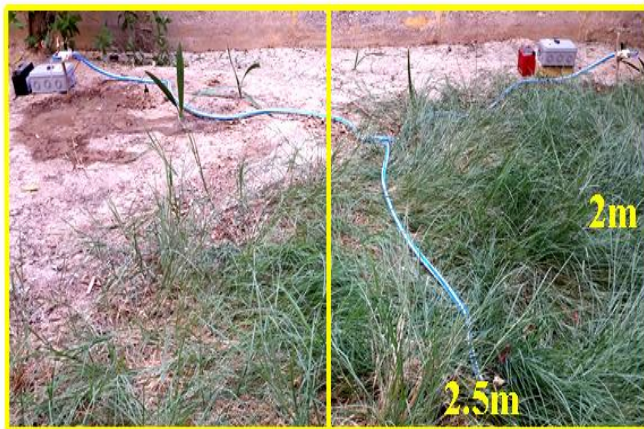

Fig. 19 System nodes in actual field.

After five minutes the sensor reading become 4V, also in this state, all irrigation conditions are still achieved, therefore, the water flowing for the plants is continued. At this time, the sensor reading is recorded to be 3V. Thus, the irrigation process is stopped. Here, the irrigation process took about ten minutes; this is determined by the time carried by the water to achieve the soil moisture sensor. It's clear that the irrigation time depend on the distance between the moisture sensor and a solenoid.

Also, it's must be noted that the irrigation conditions should be determined by the required plants parameters. Also, the irrigation process is run for ten minutes at the 5.50 o'clock PM. Fig. 20, shows the change in soil moisture, relative humidity and temperature with 24 hours.

EXPERIMENTAL RESULTS OF THE FIRST NODE

Time	Temperature (Celsius)	Relative Humidity (%)	Soil Moisture (V)	Node State
10 AM	32	22	5	ON
10:5AM	32	22	4	ON
10:10AM	32	22	4	ON
10:15AM	32	22	3	OFF
11 AM	35	20	1	OFF
12 AM	36	20	1	OFF
1 PM	38	19	2	OFF
2 PM	39	18	2	OFF
3 PM	40	18	2	OFF
4 PM	39	17	3	OFF
5 PM	36	19	3	OFF
5:50PM	35	21	4	ON
5:55PM	35	21	4	ON
6PM	35	21	4	ON
6:5PM	35	21	3	OFF
7 PM	33	21	1	OFF
8 PM	33	23	1	OFF
9 PM	32	24	1	OFF
10 PM	31	24	1	OFF
11 PM	30	25	2	OFF
12 PM	28	25	2	OFF
1 AM	27	25	2	OFF
2 AM	26	26	2	OFF
3 AM	25	27	2	OFF
4 AM	25	27	2	OFF
5 AM	24	28	3	OFF
6 AM	25	27	3	OFF
7 AM	27	26	3	OFF
8 AM	28	26	3	OFF
9 AM	30	23	3	OFF

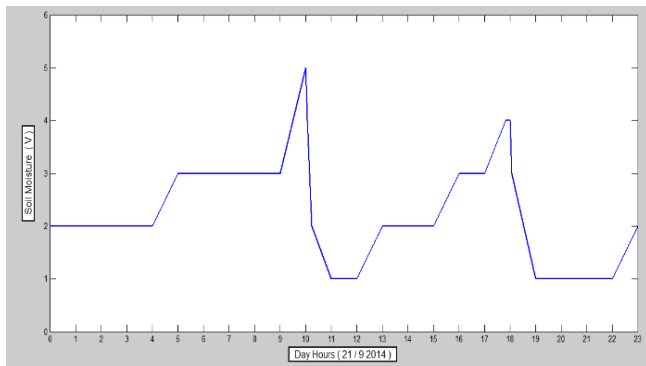

(a)

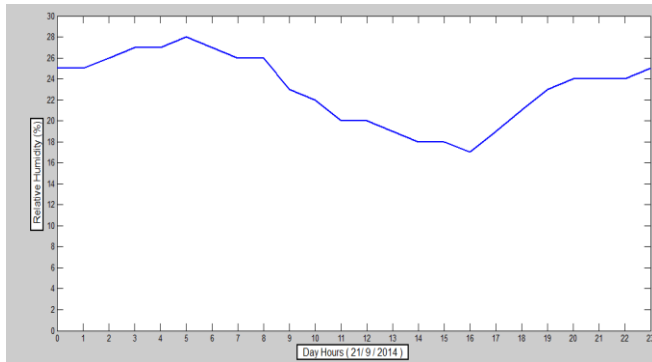

(b)

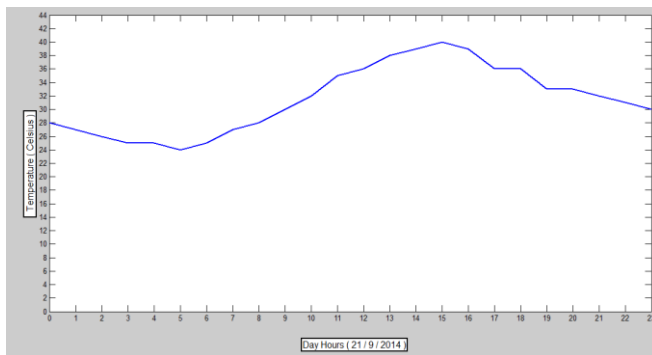

(c)

Fig. 20 First node results. (a) Soil moisture. (b) Relative humidity. (c) Air temperature during 24 hours.

VII. A SYSTEM EVALUATION

The system is tested in different environmental as shown in the previous terms. The main advantage of this system achieved in the power and cost saving. The maximum power will be consumed in the solenoid operation for allowing the water to flow to the plants. The maximum required power of this system for the

BSU is shown in Table II, and the maximum SU power is shown in Table III. From the power tables, it is noted that the maximum total current drawn by the BSU is 125mA and the maximum current drawn by the SU is 423mA. Also, noted the maximum level voltage is 12VDC, that show the system can be operated with small DC batteries with low power requirements. Table IV, illustrates the cost of the BSU and the SU cost is illustrated in the Table V.

TABLE II
BSU POWER REQUIREMENTS

Component	Current (mA)	Voltage (VDC)
Arduino Uno	50	5
LCD	30	5
XBee	45	3.3

TABLE III
SU POWER REQUIREMENTS

Component	Current (mA)	Voltage (VDC)
Arduino Uno	50	5
Solenoid Valve	300	12
DHT-22 Sensor	8	5
Moisture Sensor	20	5
XBee	45	3.3

TABLE IV
BSU COST

Component	Cost (\$)
Arduino Uno	17 \$
LCD	6 \$
XBee	24 \$
Total	47 \$

TABLE V
SU COST

Component	Cost (\$)
Arduino Uno	17 \$
Solenoid Valve	7 \$
DHT-22 Sensor	9 \$
Moisture Sensor	2 \$
XBee	24 \$
Total	59 \$

VII. CONCLUSION

In this paper, a WSN was implemented and applied to achieve smart irrigation. It's could be used to save water used for irrigation by including the controlled solenoid, less hardware involved, its need low cost when compared with classical systems. Also the system economical in power consumption. By comparison, this system with noted systems in this field it has the applicability in the frames that an away from the urban which not provided with power. This system has this advantage since, the system notes need low power and can these be provided with a rechargeable batteries with photovoltaic cell. Finally, the system has the simplicity using by the farmers.

IX. REFERENCES

- [1] G. Vellidis, V. Garrick, S. Pocknee, C. Perry, C. Kvien, M. Tucker," How Wireless Will Change Agriculture", Sixth European Conference on Precision Agriculture, University of Georgia, Tifton, Georgia, USA pp. 57-67, 2007.
- [2] Y. Kim, R. G. Evans and W. M. Iversen, " Remote Sensing and Control of an Irrigation System using a distributed Wireless Sensor Network", IEEE Transactions on Instrumentation and Measurement, vol. 57, No. 7, pp. 1379-1387, 2008.
- [3] L. R. Garcia, L. Lunadei, P. Barreiro, J. I. Robla," A review of wireless sensor technologies and applications in agriculture and food industry", International journal of Sensors and Applications, Vol. 9, pp. 4728-4750, 2009.
- [4] L. Xiu-hong , X. Cheng , K. Yan and P. Gong, " A monitoring system for vegetable greenhouses based on a wireless sensor netwo", International Journal of Sensors and Applications, Vol. 10, pp. 8963-8980, 2010.
- [5] R. Atta1, T. Boutraa, A. Akhkha," Smart irrigation system for wheat in Saudi Arabia using wireless sensors network technology", International Journal of Water Resources and Arid Environments, Vol. 1, PP. 478-482, 2011.
- [6] V. Ramya, B. Palaniappan , B. George," Embedded system for automatic irrigation of cardamom field using Xbee-PRO technology ", International Journal of Computer Applications, Vol.53, pp. 36-43, 2012.
- [7] V. Divya, A. Umamakeswari," Smart irrigation technique using vocal commands", International Journal of Engineering and Technology, Vol. 5, pp. 385-390, 2013.
- [8] G. Joaquin. F. Juan, M. Villa, N. Alejandra," and Miguel A. P., Automated Irrigation system using a wireless sensor network and GPRS module, IEEE Transactions on Instrumentation and Measurement, vol. 63, no. 1, pp. 166-176, January, 2014.
- [9] A. N. Srivastava, and R. Singh," Wireless sensor networks in agriculture: for potato farming", International Journal of Engineering Science and Technology, Vol.2, pp. 3955-3963, 2010.
- [10] R. Piyare, S. R. Lee," Towards internet of things (iots): integration of wireless sensor network to cloud services for data collection and sharing", Vol. 5, pp.59-72, 2013.
- [11] Temperature and humidity module AM2302 Product Manual, www.aosong.com
- [12] D. Hsu, J. S. Park, M. Vahabzadeh,Y. Zhang," Design specification for the smart plant design", School of Engineering Science Simon Fraser University Burnaby, British Columbia, Vol. 5, 2013.