

Design and Performance Analysis of an Active Power Factor Corrector

تصميم و تحليل أداء مصحح فعال لعامل القدرة

M.Sc. Haider MuhamedUmran

University of Kerbala / College of Engineering / Electrical and Electronic
Engineering Department\Power Electronics

E-mail: hyderumran@yahoo.com

Abstract:

Electrical devices, which mostly used at houses, industrial, commercial purposes and other applications, require amendment for its power to some standard forms. Typically, rectification would be necessary for a proper operation and for a high performance. The electrical devices are represented as non-linear loads therefore, it is producing a non-sinusoidal current, and as a result, they are working with a poor power factor.

In this research paper, an active power factor correction circuit designed by using Switch Mode Power Supply (SMPS) "Buck Converter" type, to improve the power factor. The input parameters are 220V, 50Hz. Moreover, the Average Current Mode Control (ACMC) method has been implemented to observe the effect of the corrected active power factor on the circuit. The research starts with the study of the power factor and designing the proposed system. The software P-SIM (6.1) will be used in designing the circuit and viewing the waveforms. The main advantage of use P-SIM software is providing a powerful simulation environment for power electronics and power conversion systems. Finally, the simulation results in the current research are compared with the adopted research results.

الخلاصة:-

اغلب الأجهزة الكهربائية، التي تستخدم في المنازل و الصناعة و في الاغراض التجارية وغيرها من التطبيقات، تحتاج إلى تعديل قدرتها إلى بعض الاشكال القياسية. عادةً، تكون التصحيح ضرورياً لضمان عمل تلك الاجهزة بشكل صحيح و بأداء عالي. تمثل الأجهزة الكهربائية كالأحمال غير الخطية لذلك فإنها تنتج تيار خط غير جيبي، ونتيجة لذلك فإن تلك الاجهزة تعمل بمعامل قدرة ضعف. في هذه البحث، تم تصميم دائرة تصحيح معامل قدرة نشيطة باستخدام مجهز القدرة ذات النمط المفتاحي نوع المحول الخافض لتحسين معامل القدرة. معلومات الادخال للدائرة هي 220 فولت و بتردد 50 هيرتز. علاوة على ذلك، تم تنفيذ اسلوب السيطرة على متوسط التيار (ACMC) لمراقبة تأثير تحسين معامل القدرة الفعال على الدائرة. بدأ البحث بدراسة معامل القدرة وتصميم النظام المقترح. لقد استخدم برنامج المحاكاه P-SIM (اصدار 6.1) في تصميم الدائرة و عرض الاشكال الموجية. ان الفائدة الاساسية من برنامج المحاكاه P-SIM هو توفر بيئة محاكاة قوية لالكترونيات القدرة و انظمة تحويل الطاقة. اخيراً تم مقارنة نتائج المحاكاة في البحث الحالي مع نتائج البحث المعتمد.

1. Introduction:

Power factor is simply defined as the ratio of the real power to the apparent power, as follows:

$$PF = \frac{P}{S}$$

Where P is the real power, it's the average, over a cycle, of the instantaneous product of current and voltage, and S the apparent power is the product of the value of current, times the value of voltage. If both current and voltage are sinusoidal and in phase the power factor equals to 1.0, but if both are sinusoidal but not in phase, the power factor is the cosine of the phase angle [1]. Power factor correction has become a challenge facing for designers of hardware. There are main benefits of PFC, like: Improved energy efficiency reduced system currents and kW losses, security of supply

reduction in peak currents prevents fuse failure and loss of supply and eliminating expensive utility penalties for a poor power factor, etc.

Recently, there are many researches have done in the field of PFC applications. However, Gawade, et al. [2] implemented a single phase, PWM buck converter at quarter load and full load to power factor from 0.864 to 0.95 at full load. Mula [3] designed a power factor corrector by using a fly back converter in parallel with forward converter for medium-power applications. Mitra, et al. [4] analyzed and simulated an active power factor corrector using a boost converter, where MOSFET is driven by the regulated pulses. Al Mansur, et al [5] developed and simulated a single phase power factor correction by using a passive filter and boost rectifier. Where used a full wave rectifier with input LC passive filter as PFC. The designer use a large capacitor at the output to get pure d.c output voltage, but THD rose to 200%. Another drawback to this design it does not have any voltage control option. According to the results achieved, it is clear that, when the inductive filter increase, the capacitive filter is decreased and the output voltage (V_o) is decrease. The efficiency also decreases at this condition. Boost rectifier with active switching has been used for different duty cycle, to solve the problems of a passive filter. Used of a boost converter for output voltage regulation, reduce the value of THD and increase efficiency. A power factor correction circuit using Boost Converter possesses 1% to 3% lower efficiency at 100 Volts than that at 230 V. This is due to increased input current that produces higher losses in semiconductors and input filters. Also the high output voltage of Boost Converter in (380-400) V range has a detrimental effect on its switching losses and on the size and efficiency of the isolation transformer [5, 16]. The above drawbacks of Boost Converter in Power Factor Correction circuit can be overcome by using Buck Converter. In this research, an active power factor correction achieved by using Switch Mode Power Supply (SMPS) "Buck Converter". The block diagram for the design, as shown in Fig.1.

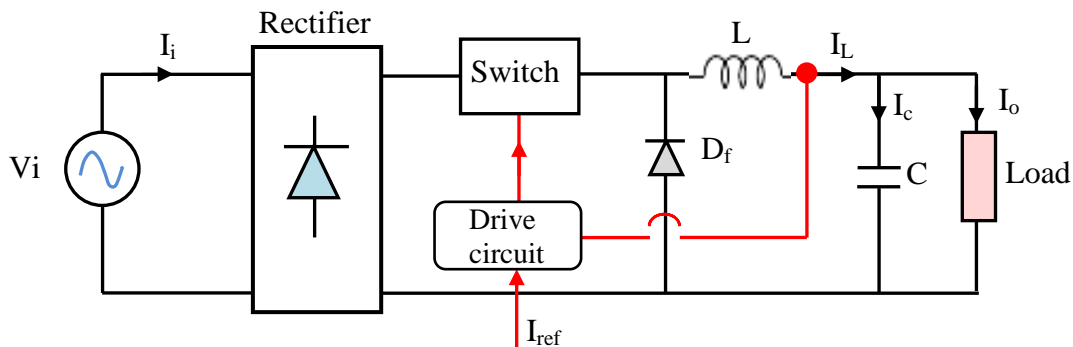

Fig (1): Block diagram of the system design.

A switched mode power supply represents nonlinear impedance to the mains, as a result of the input circuitry. The input circuit usually consists of a full-wave rectifier followed by buck converter circuit and storage capacitor able to maintaining voltage to approximately value of peak voltage for the input sine wave until the next peak comes along to recharge the capacitor. In this case, the current is drawn from the input only at the peaks of the input waveform and this pulse of current must contain enough energy to sustain the load until the next peak. Average Current Mode Control method (ACMC) has been implemented with buck converter to observe the effect of the active power factor corrector on the power factor [1, 9].

1.1. Active Power Factor Correction:

An active PFC is a power electronic device designed to control the amount of power drawn by a load and obtain a power factor as close as possible to unity. Commonly, the design functions of any an active PFC is the controlling on the input current in order to making the current waveform in phase with supply voltage waveform it closer to a sine wave. The combination of the reactive elements and some of the active switches increase the effectiveness of the line current shape to obtain controllable output voltage [10].

There are many advantages to using an active PFC such as: light weight system, small size, power factor value of over 0.95, reduces the harmonics which are present in the system, automatic correction for the ac input voltage and it's capable to operating in a full range of voltage. [6, 9, 12].

1.2. Performance Parameters of Input Supply:

The performance can be measured with the help of the following terms as given below:-

a) Input Power Factor:
$$P.F = \frac{\text{Main input power}}{\text{RMS input voltamperes}}$$

If the supply voltage is undistorted, then only the fundamental component of the input current, would contribute to the main input power.

Therefore,
$$P.F = \frac{V I_1 \cos \theta_1}{V I}$$

Where, V the RMS value of supply phase voltage(220V), I the RMS value of supply phase current, I_1 the RMS value of fundamental component of the supply current and θ_1 is angle between the supply voltage and fundamental component of the supply current. The input power factor is very important it decides how much volt-ampere is required by the system.

b) Input Displacement Factor DF: It related to displacement angle (θ_1) between the input, or source, voltage and the fundamental component of the input current of the frequency changer system. The displacement factor which is often referred to as the input power factor. Where $DPF = \cos \theta_1$. For a certain power demand, if displacement factor is low, then large value of fundamental current is drawn from the supply.

c) Harmonic factor: The Harmonic Factor (HF) gives us idea about the harmonic contents in the input supply current and measures the Total Harmonic Distortion (THD). THD is inversely proportional with the power factor (PF), as in the graph shown in Fig. 2. [6, 7, 13].

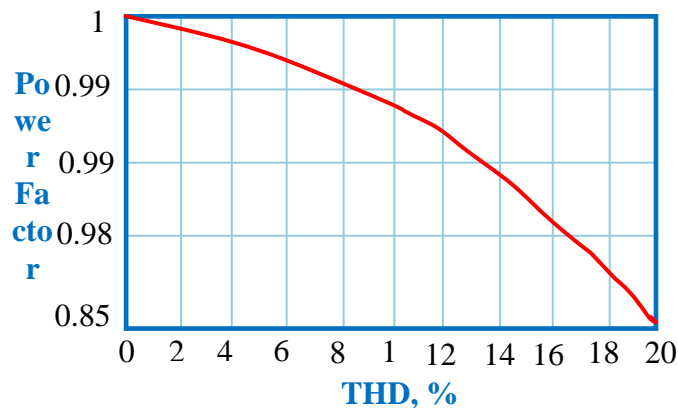

Fig. (2): Graph showing Power Factor vs. Total Harmonic Distortion[13].

The input current is non-sinusoidal in nature; it contains currents of harmonic frequencies and defined as:-

Harmonic Factor (HF) =
$$\frac{\sqrt{I^2 - I_1^2}}{I_1}$$
 or
$$HF = \frac{I_n}{I_1}$$

Where, I_n : The RMS value of n^{th} harmonic current. The Harmonic Factor (HF) is an important term, where gives an idea about the harmonic contents in the input supply current and measures the THD.

2. Operation Analysis of a Buck Converter:

A buck converter is used to convert an unregulated dc input to a regulated dc output voltage, at any desired voltage value. In this type of converter the output voltage is less than the input voltage $V_i > V_o$. This converter consists from input voltage source V_i , power controlled switch, diode D_f is usually called the catch diode or freewheeling diode, inductor, L , and capacitor, C . The resistor R represents the load seen by the power stage output [9, 15]. The simplified circuit diagram for a buck converter as in Fig. 3.

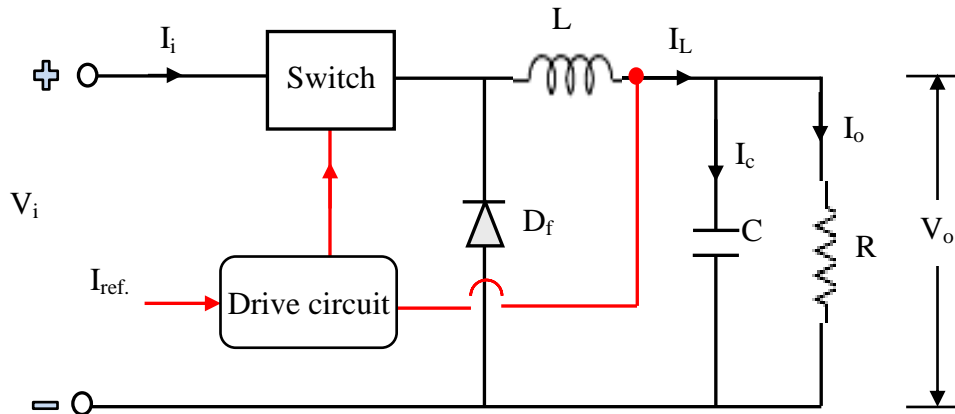

Fig (3):Buck Converter.

3.Operation Modes of Buck Converter:

The buck converter can have two distinct modes of operation: Continuous conduction mode (CCM) and discontinuous conduction mode (DCM). In practice, a converter may operate in both modes, which have significantly different characteristics. However, this research considers the buck converter operating in (DCM).

3.1 ON Current Mode:

When transistor is switched ON, ($T_{ON} = D \times T_S$), Where (D) is the duty cycle set by the control circuit and expressed as a ratio of the switch ON time to the time of one complete switching cycle, (T_S). In this case the inductor current and the diode (D_f) becomes reverse biased. Therefore, the voltage across inductor ($V_L = V_i - V_o$). This voltage causes a linear increase in the inductor current I_L [6].

3.2 OFF Current Mode:

When transistor is switched OFF, the duration of this state is called T_{OFF} . Where ($T_{OFF} = 1 - D \times T_S$). The diode (D_f) becomes forward-biased because the stored energy in the inductor and current flowing through L , C , and the D_f . [6, 8].

The waveforms of switching state, current and voltage during discontinuous conduction mode (DCM) operation of Buck Converter are as shown in Fig.4.

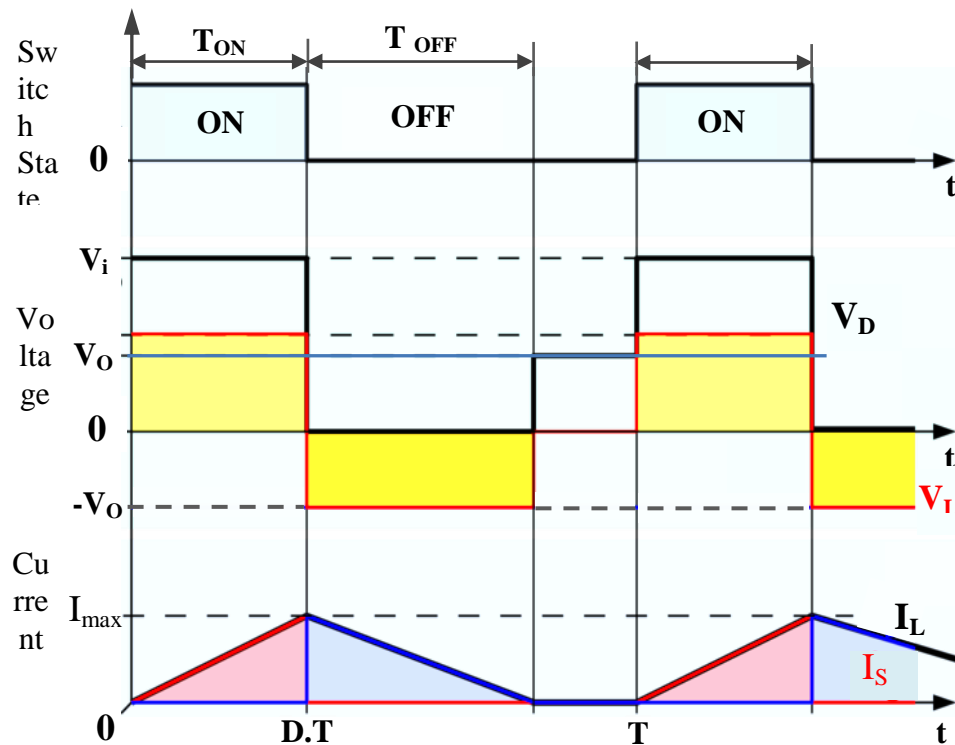

Fig (4): Buck convertor waveforms during DCM[15].

4. Design of Power Factor Corrector:

This design focuses on analysis of buck converter under discontinuous conduction mode (DCM). The specifications of proposed for designing the active power factor corrector is: Input voltage 220 V ac, line frequency 50 Hz, output voltage 130 V dc and maximum output power 660 W. Even though the power stages of design vary, but the design process is the same for all ratings.

4.1 Selection of Switching Frequency:

There are many considerations must be taken into account in selection of switching frequency, such as:

i. Minimize the size of power circuit, where the inductors and capacitors are chosen according to the following formulas:

$$V_i = L \times di/dt$$

$$\text{Rearranging: } L = \frac{V_i \times D \times (1-D)}{\Delta I_L \times f_s} \quad \dots 1$$

$$\Delta I_L = \frac{(V_i - V_o) \times D}{f_s \times L} \quad \dots 2$$

And $I = C \times dv/dt$

Rearranging:

$$C = \frac{\Delta I_L}{8 \times f_s \times \Delta V_c} \quad \dots 3$$

Where D is duty cycle, ΔI_L the estimated inductor ripple current, f_s switching frequency of the converter and ΔV_c the desired output voltage ripple. According to Eq. 3, evidently, the switching frequency is inversely proportional with the values of (L and C) and the ripple current will reduce when the switching frequency is increasing. Depending upon this considerations, the value of switching frequency is selected 100 KHz.

ii. Limit for the controllable pulse width results in a minimum achievable duty cycle, which can be calculated as:

$$\text{Minimum duty cycle} = T_{ON} \times f_s \quad \dots 4$$

iii. Minimum duty cycle it means the lowest output voltage can be achieved, which can be calculated as:

$$V_o = V_i \times \text{Minimum duty cycle} \quad \dots 5$$

$$\text{Therefore, duty cycle (D)} = \frac{V_o \times \eta}{V_i} \quad \dots 6$$

The efficiency of the converter added in Eq. 6, because the converter also has to deliver the energy dissipated. This calculation gives a more realistic duty cycle than the formula without an efficiency factor. Where, the efficiency (η) is chosen 96%. This value of efficiency is not unrealistic, where 90% for a buck converter is worst - case efficiency [6].

4.1.1 Selection of Inductor:

The value of inductor can be selected from the value of maximum peak current (I_{pk}) which flows through it, when the input voltage has minimum value. The maximum peak line current I_{pk} at $P_i = P_o$ (max) = 660W.

$$I_{pk} = \frac{P_i}{V_i} = 4.24 \text{ A.}$$

a. Ripple of current :

The inductor ripple current cannot be calculated with Eq. 2, because the inductor is not known. A good estimation for the inductor ripple current is 20% to 40% of the output current. In this design, the inductor ripple current is chosen 30% of the peak line current (I_{pk}).

$$\Delta I_L = 30\% \times I_{pk} = 1.272 \text{ A.}$$

b. The duty cycle (D) at maximum peak current (I_{pk}), can be calculated according to Eq. 6 as:

$$D = \frac{V_o \times \eta}{V_i} = 0.57$$

Hence, inductance L is calculated as:

$$L = \frac{V_{i(r.m.s)} \times D \times (1-D)}{\Delta I_L \times f_s} = 0.3 \text{ mH.}$$

4.1.2 Selection of Output Capacitor:

The output capacitor is used to minimize the ripple on the output voltage, according to Eq. 3, the capacitor is calculated depending on the peak to peak ripple voltage. In this design ΔV_c is assumed 20mV [6].

$$C = \frac{\Delta I_L}{8 \times f_s \times \Delta V_c} = 79.5 \mu\text{F.}$$

5. Average Current Mode Control (ACMC):

Typically, the Average Current Mode Control technique dividing into two loops: an inner loop (current) and outer loop (voltage) for power electronic converters. The main advantage of ACMC is providing high gain integrating current error amplifier (CA) into the current loop. A voltage across R_p (set by the outer loop) represents the desired current program level. According to control structure as shown in Fig. 5, the voltage across current sense resistor R_s represents actual inductor current. The difference, or current error, is amplified and compared to a large amplitude saw tooth (oscillator ramp) at the PWM comparator inputs [14]. The inductor current follows the demanded current reference with very small error, as a controlled current source. The input current of buck converter is forced or programmed to be proportional to the input voltage waveform for power factor correction. The output of the buck regulator is constant voltage but the input current is programmed by the input voltage. This method involves the control of both the input current and the output voltage [10]. Therefore, in this research the control circuit for the buck converter is implemented using Average Current Mode Control (ACMC) method.

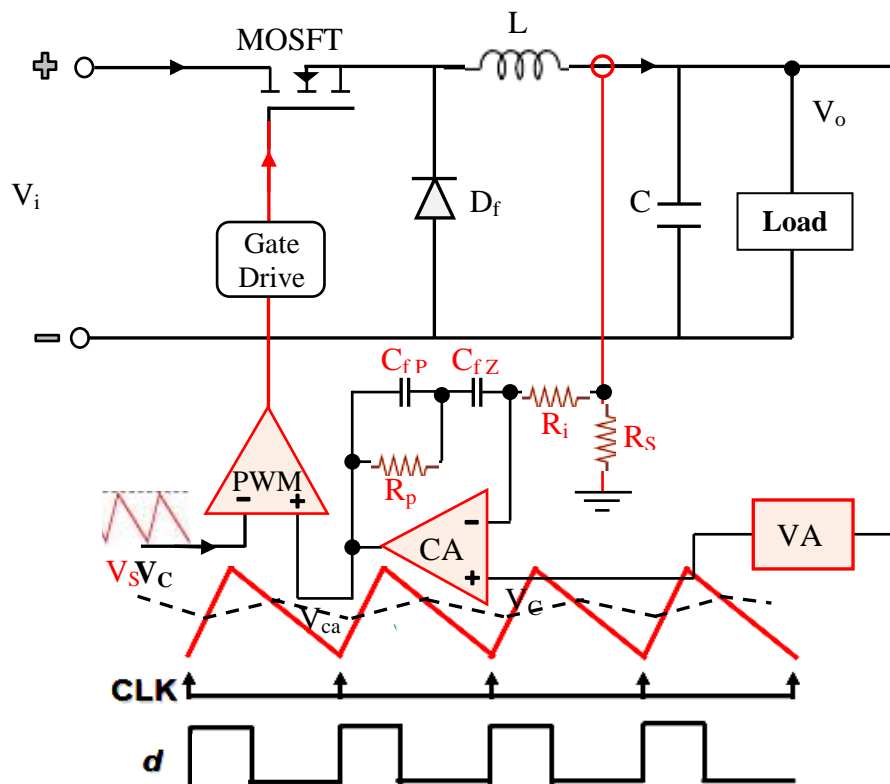

Fig (5): Average Current Mode Control Circuit and Waveforms [14].

6. Simulation of the PFC Design:

The P-SIM software has been used for carrying out the simulation circuit shown in Fig. 6. The P-SIM is a simulation environment includes the circuit schematic, the simulation engine and the SIMVIEW for viewing the waveforms. This program is a highly interactive and user-friendly in building the circuit as well as editing it. The circuit diagram of proposed PFC using buck converter as shown in Fig. 6.

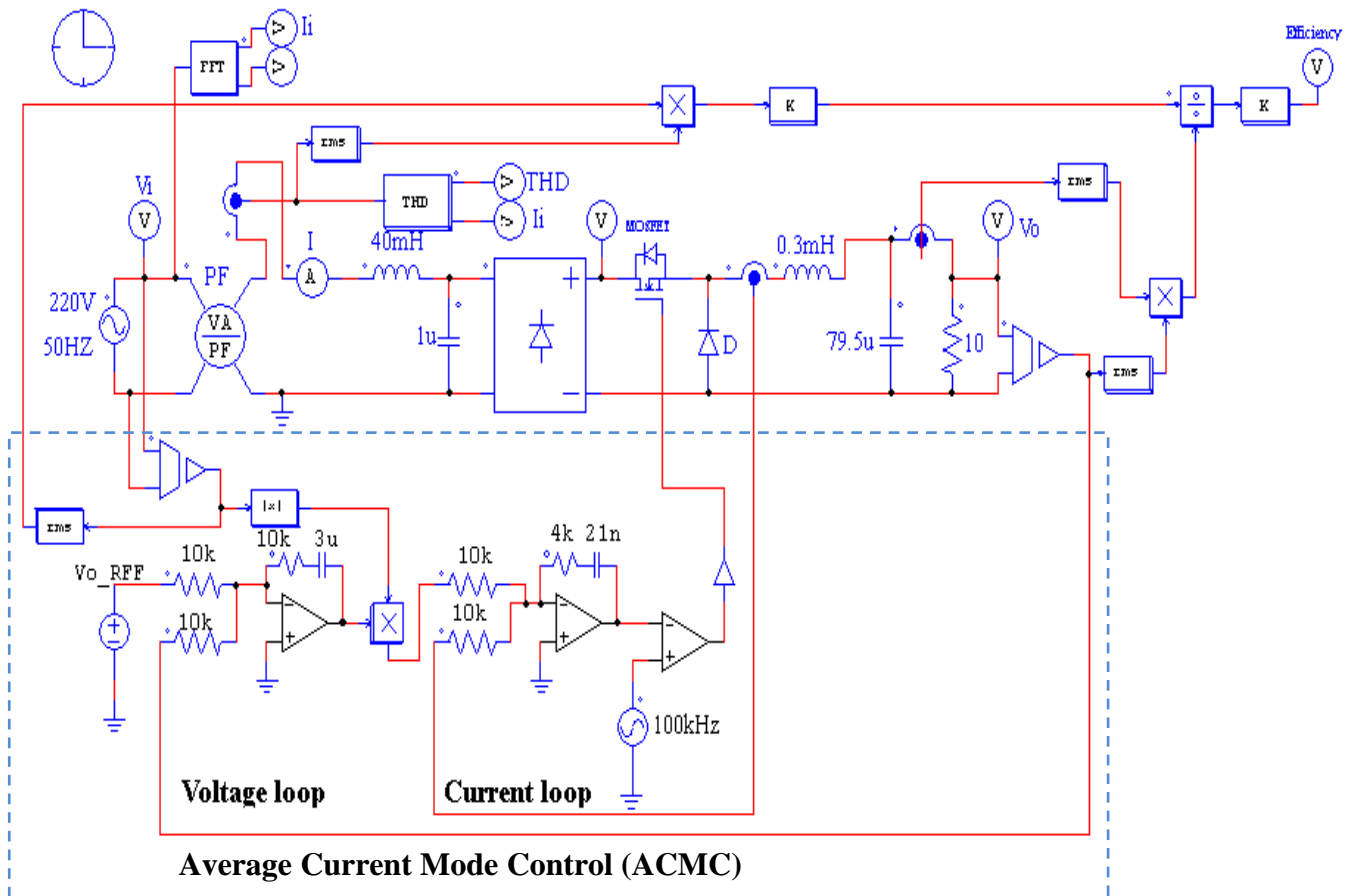

Fig (6): Circuit Diagram of PFC using Buck Converter.

7. Simulation Results:

The results which are obtained in this design are compared with the results illustrated in [5]. Several parameters are compared such as: the input current and voltage, D.F, FFT analysis of the input current, THD, efficiency, power factor and other factors related to the both of the design styles. The comparison is made by two phases: first, comparing the obtained results in this research with the results in [5], for rectifier with input LC passive filter. This done through implementation the circuit of rectifier with input LC passive filter and extracting the input and output waveforms. Second, comparing the obtained results in this research with the results in [5], for the boost converter.

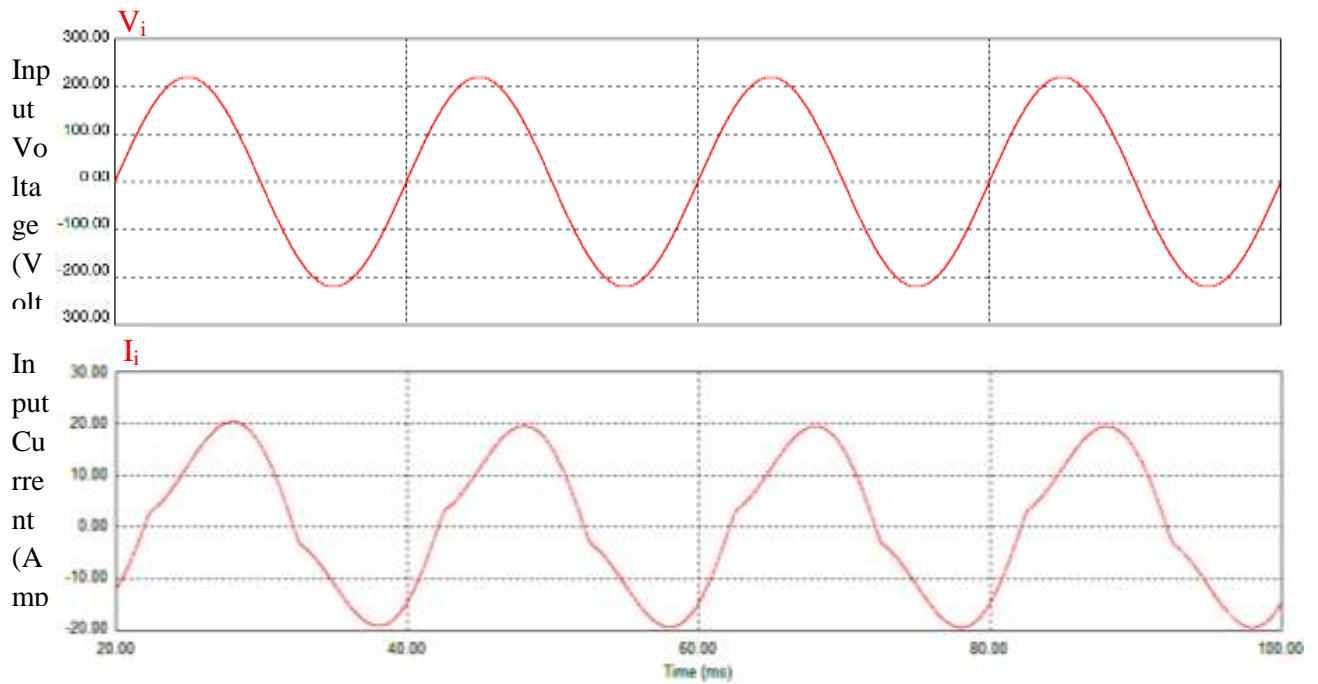

Fig.(7): Waveforms of Input Voltage (V_i) and Input Current (I_i) for Rectifier with Input LC Filter for [5].

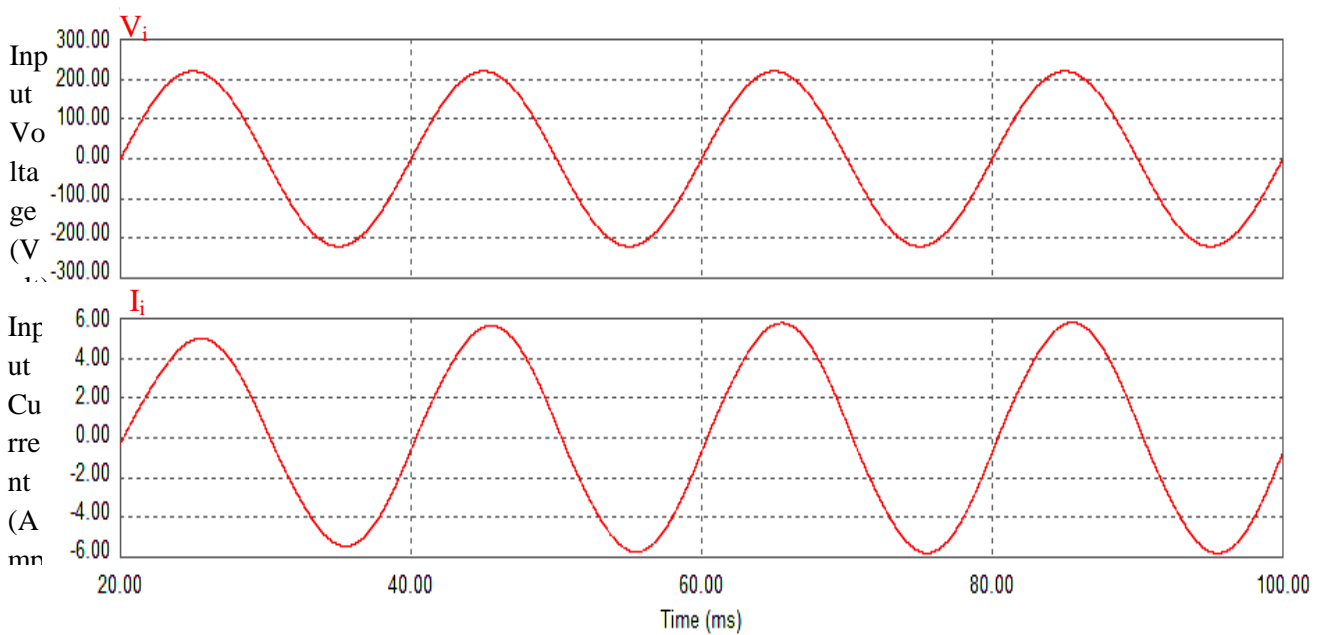

Fig (8): Waveforms of Input Voltage (V_i) and Input Current (I_i) For the Proposed Design.

The displacement angle (θ) between input voltage wave and input current wave as shown in Fig. 7, is 21.6° . Therefore, the power factor equal 0.93. While the displacement angle (θ) between input voltage wave and input current wave in Fig. 8, is closer to zero. Therefore, the power factor approximately equal to 1, which is considered as a good improvement.

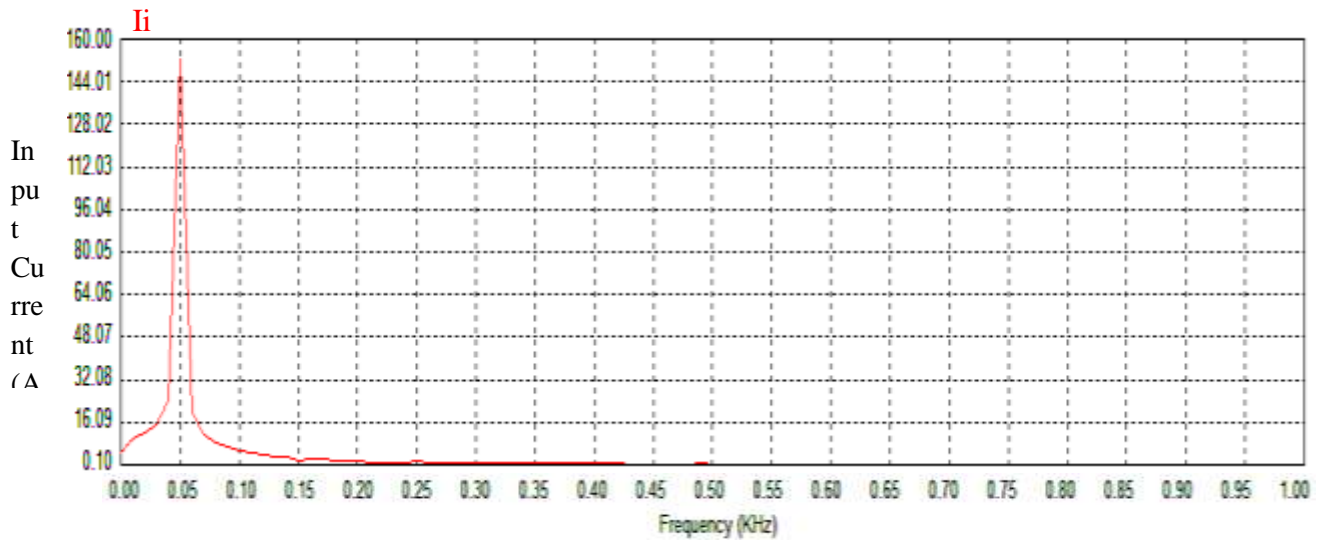

Fig. (9):FFT Analysis of the Input Current (I_i)for Rectifier with Input LC passive filterfor [5].

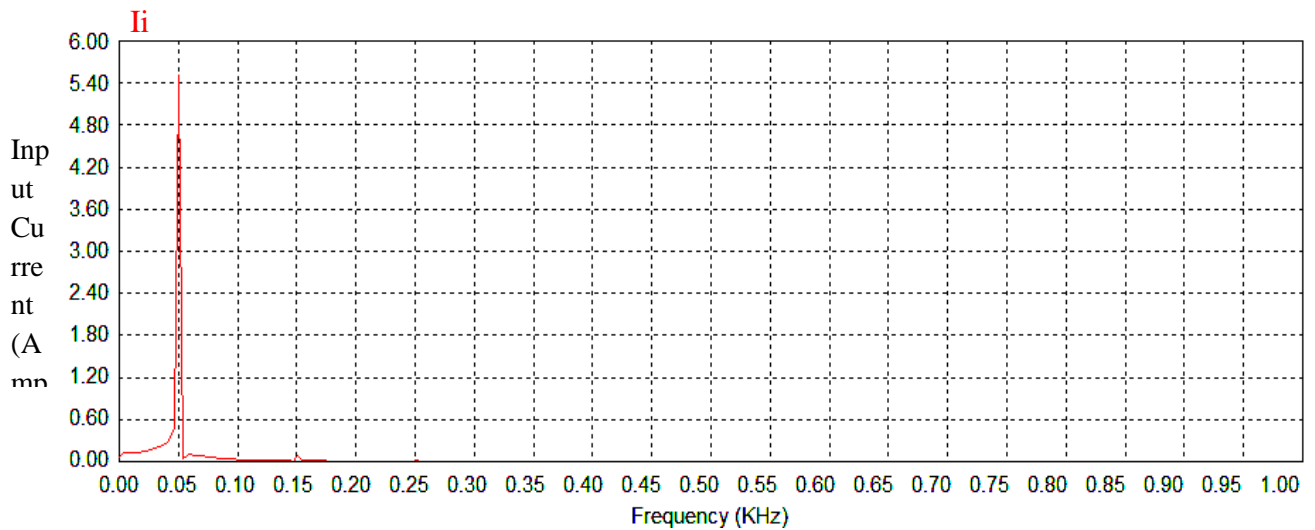

Fig (10): FFT Analysis for the Input Current (I_i)For the Proposed Design.

As shown in Fig. 9, the value of fundamental input current equal 148 A, this value is great if compared with the result obtained in the Fig. 10; where the value of fundamental input current is equal to 5.48 A, Which means less distortion in the input waveform and a great deal of reduction in losses.

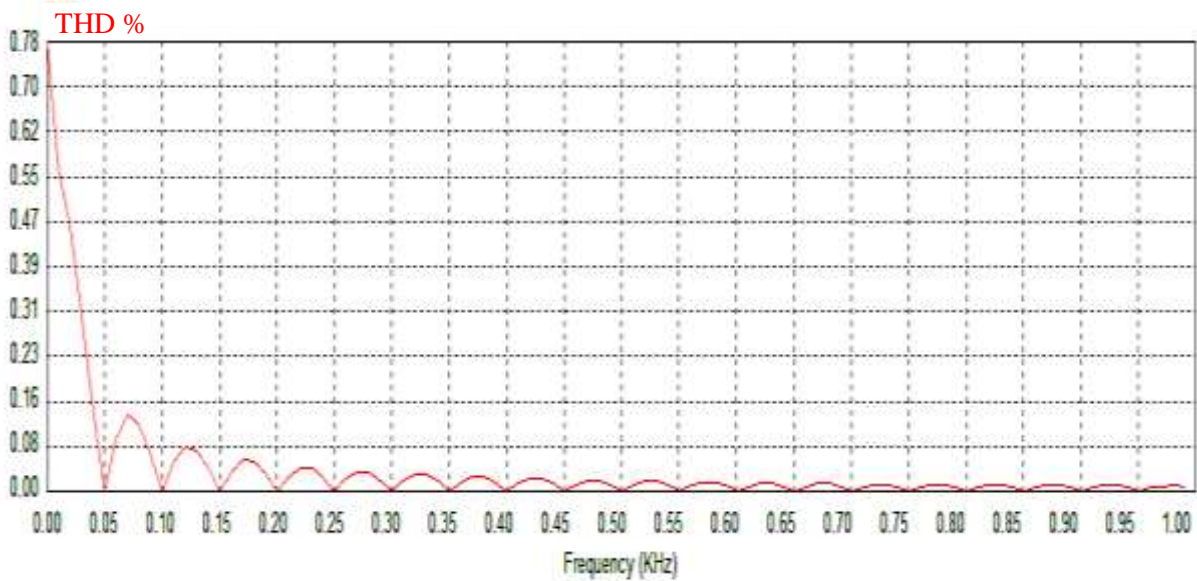

Fig (11): THD Analysis of Input Current (I_i)forRectifier with input LC passive filterfor [5].

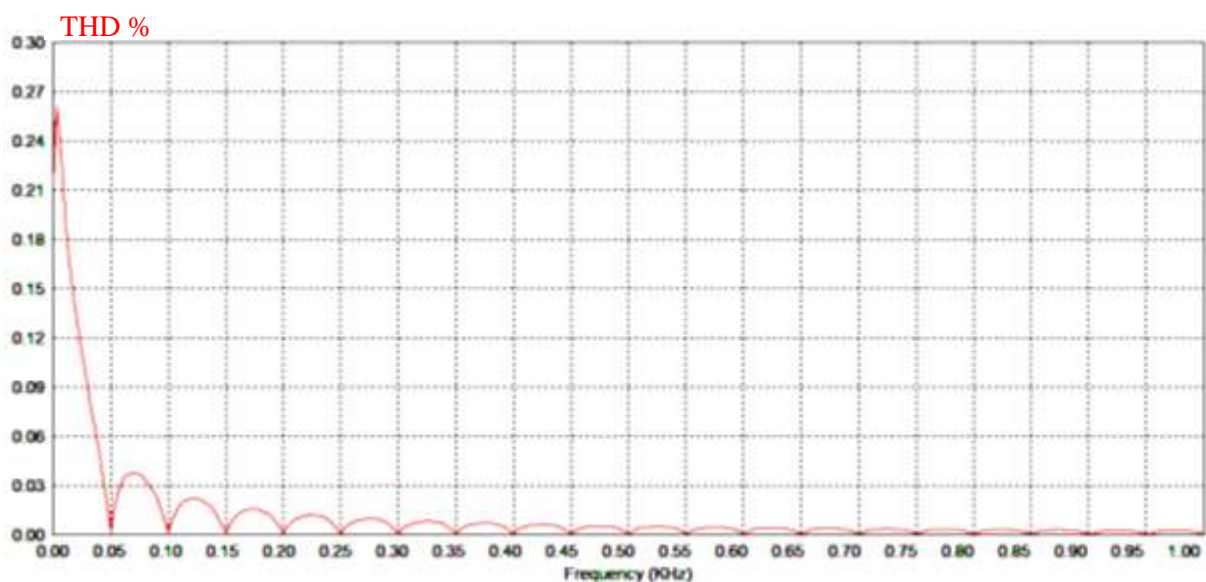

Fig (12): THD Analysis for Input Current (I_i)For the Proposed Design.

The value of THD is less than 1% and is equal specifically to 0.78 as shown in Fig. 11. While the obtained value for THD equalto 0.244, as shown in Fig. 12. This value is natural relative to the value of power factor which is obtained, since THD is inversely proportion with power factor.

The comparison between results obtained in this research and the verified results in [5] for boost converter are summarized in Table 1. The comparison on the basis of the values which approached to the parameters adopted in this research.

Table 1: The obtained results Vs the results in [5].

| Parameters | D.F (θ_1) | I_i (Amp.) | η (%) | P.F | Duty Cycle (D) | THD % |
|----------------|--------------------|--------------|------------|------|----------------|-------|
| Reference[5] | 21.6° | 148 | 91 | 0.93 | 0.488 | 0.619 |
| Design Results | 0.001° | 5.48 | 96 | 0.99 | 0.59 | 0.244 |

8. Conclusion:

In this research a power factor correction is designed using buck converter. Results in-terms of THD, D.F, P.F, FFT for the input current and the efficiency of the system show that in proposed design THD equals to 0.244% while research [5] THD equals to 0.619%, the D.F in proposed design equals to 21.6° while research [5] D.F equals to 0.001°, the P.F in proposed design equals to 0.99 while research [5] P.F equals to 0.93, the FFT analysis for the input current in proposed design equals to 5.48A while research [5] FFT analysis for the input current equals to 148A and the efficiency in proposed design equals to 96% while research [5] efficiency equals to 91%. Using (ACMC) with buck converter tracks any change in instant current with a high degree of accuracy. This has a great deal of impact in P.F correction than other control techniques.

References:

1. ON semiconductor, Literature Distribution Center “Power Factor Correction (PFC) Handbook”, N. American Technical Support, Rev. 4, (2011).
2. P. L. Gawade, A .N. Jadhav, and T. B. Mohite - Patil “Power Factor Correction In Single Phase Buck Converters By PWM Control [PFC]”, International Journal of Engineering Research & Technology, Vol. 2, Issue 5, ISSN: 2278-0181, May (2013).
3. S. R. Mula “Power Factor Correction”, International Journal of Inventive Engineering and Sciences (IJIES), Vol. 1, Issue-12, ISSN: 2319–9598, November (2013).
4. L. Mitra, C.K. Pangrahi, “Active Power Factor Correction Methods” International Journal of Electrical Engineering and Technology (IJEET), Vol. 1, pp. 32-46, ISSN 0976 – 6545, May - June (2010).
5. Al Mansur, Abdullah Al Bashit, A.S.M. Mahfuzur Rahman, Md. ShahinurAlam, and Hasina Begum, “Improvement of Input-Side Current of a Single Phase Rectifier with Variable Output Voltage Range using Boost Converter and Investigation of Harmonic Minimization” International Journal of Scientific & Engineering Research, Vol. 4, ISSN 2229-5518, Issue 3 March (2013).
6. Brigitte Hauke, “Basic Calculation of a Buck Converter's Power Stage”, Texas Instruments Incorporated, Dallas, Texas 75265, (2012).
7. Laszlo Huber, Member IEEE, Liu Gang and Milan M. Jovanovic, Fellow, IEEE, “Design Oriented Analysis and Performance Evaluation of Buck PFC”, Vol. 25, ISSN 0885-8993, Issue1, Jan. (2010).
8. M. H. Rashid, “Power Electronics Circuits Devices and Applications”, Pearson Education India Series Private Limited, New Delhi, (2004).
9. D. O. Neacsu, “Power-Switching Converters: Medium and High Power”, Taylor & Francis Group, LLC, CRC Press, United State, May 25, (2006).
10. Raymond L. Barrett, Jr., “Switch mode Buck power Converter Using Current –Mode Control”, SunCam Online Continuing education course, (2010).
11. H. Z. Azazi, E. E. EL-Kholy, S. A. Mahmoud and S. S. Shokralla, “Review of Passive and Active Circuits for Power Factor Correction in Single Phase, Low Power AC- DC Converters” Proceedings of the 14th International Middle East Power Systems Conference (MEPCON'10), Cairo University, Egypt, Paper ID 154, December (2010).
12. TemesiErno, Michael Frisch, Vincotech GmbH. “PFC-Fundamentals, 2. Active Power Factor Correction–Principle of Operation” Tyco Electronics/Power Systems, Germany, January (2004).
13. Jain Sandesh, Thakur Shivendra Singh and Phulambrikar S. P., “Improve Power Factor and Reduce the Harmonics Distortion of the System”. Research Journal of Engineering Sciences, Vol. 1(5), 31-36, India, November (2012).
14. Lloyd Dixon, “Average Current Mode Control” Texas Instruments Incorporated, Topic 5, Dallas, Texas 75265, (2001).
15. P. Julián, A. Oliva, P. Mandolesi, and H. Chiacchiarini, “Output discrete feedback control of a DC-DC Buck converter,” in Proceedings of the IEEE International Symposium on Industrial Electronics (ISIE'97), pp. 925–930, Guimaraes, Portugal, Julio (1997).
16. Huber, L., Liu Gang; Jovanovic, M.M., “Design-Oriented Analysis and Performance Evaluation of Buck PFC Front End”, Power Electronics, IEEE, Vol. 25, Issue 1, ISSN 0885-8993, Jan. (2010).