

Experimental Behavior of Circular Steel Tubular Columns Filled with Self-Compacting Concrete under Concentric Load

Dr. Ammar A. Ali

Building and Construction Engineering Department, University of Technology/Baghdad
Email: ammarbagh@yahoo.com

Dr. Wael S. Abdul-Sahib

Building and Construction Engineering Department, University of Technology/Baghdad

Saad N. Sadik

Building and Construction Engineering Department, University of Technology/Baghdad

Received on: 5/9/2012 & Accepted on: 9/5/2013

ABSTRACT

This paper presents an experimental study on the behavior of circular, concrete-filled, steel tube (CFT) columns concentrically loaded in compression to failure. Self-compacting concrete (SCC) is used here as a filler in order to increase homogeneity of the core and reduce segregation problems. Total six column specimens with different lengths (0.4 m – 1.5 m) of constant diameter of 160 mm and wall thickness of 2.8 mm were tested. The purpose here is to investigate the ultimate capacity and the deformation behavior of different slenderness ratio columns. The behavior of these columns in confinement was discussed.

Experimental results indicate that the compression force capacity is affected by slenderness ratio of the column. For slender column the overall buckling was observed while for the short columns the crushing and the local buckling is the dominant failure shape.

Keywords: circular, column, steel, SCC, slenderness

السلوك العملي للاعمدة الفولاذية الانبوبية الدائرية و المملوءة بالخرسانة ذاتية الرص تحت تأثير حمل محوري

الخلاصة

البحث الحالي يتناول دراسة عملية لتصرف الاعمدة الدائرية مكونة من انبوب فولاذي ذو املاء خرساني و تحت حمل انضغاط محوري. تم استخدام الخرسانة ذاتية الرص للملء و ذلك لزيادة تجانس اللب الخرساني و تقليل احتمالية الانفصال في الخرسانة. تم فحص ست عينات باطوال مختلفة (0.4 م – 1.5 م) و ذات قطر ثابت قدره 160 ملم و سمك الجدار 2.8 ملم. الغرض من البحث هنا هو لبحث قدرة التحمل القصوى و تصرف التشوه للاعمدة ذات معامل نحافة مختلفة. تم ايضا مناقشة تأثير عامل الحصر على تصرف الاعمدة.

النتائج المختبرية بينت ان مقاومة الاعمدة للانضغاط تعتمد على نسبة النحافة للاعمدة. تم ملاحظة ان الاعمدة النحيفة يكون الفشل فيها بانبعاج كلي بينما الاعمدة القصيرة تعاني من تهشم الخرسانة و انبعاج محلي.

INTRODUCTION

Concrete-filled steel tubes (CFTs) are practical and economical structural elements that permit rapid construction because the steel tube serves as formwork and reinforcement to the concrete fill, negating the need for either. Furthermore, the empty tube and the concrete fill are rapidly placed, and placement of the concrete fill is further enhanced using self-compacting concrete as vibration is not required. The deformation capacity of the system is increased by the combined action of the concrete fill with the thin, ductile steel tube. The concrete fill significantly increases inelastic deformation capacity and the compressive stiffness and load capacity of the CFT member. The fill also increases local and global buckling resistance by stiffening the walls of the tube and increasing the slenderness ratio; KL/r value, where K is effective length factor, L is the column length and r is the radius gyration of the column section. This increased deformation capacity benefits the use of CFT components for blast resistance and seismic design [1].

CFTs are circular or rectangular composite members. Shear stress transfer is needed between the steel and concrete to develop composite action. Researches [3, 4] show that circular CFTs provide greater bond stress transfer, better confinement, and greater shear reinforcement to the concrete fill than rectangular CFTs. Nevertheless, the bond stress for all CFT members is limited, and careful attention must be paid for CFT components with high axial load. Modest bending moments and some structural connection details enhance bond stress transfer, and so research on the combined loading issues is an important design consideration. With their high axial load-carrying capacity, CFTs are suitable for bridge piers and columns of taller buildings, and circular CFTs are preferable. However, rectangular CFTs are often used in practice because the design provisions and the structural connections for circular CFTs are not well defined. To encourage the use of circular CFTs in structural design, both must be overcome.

Self-Compacting Concrete (SCC) is drawing increasing interest because it allows casting of concrete without the need of trained personnel even in presence of a high congestion of the reinforcement. Two important properties specific to SCC in its plastic state are its flowability and stability. The stability or resistance to segregation of the plastic concrete mixture is attained by increasing the total quantity of the fine aggregate in concrete or by increasing the cement content. Also, well distributed of aggregate grading help to reduce the cement content and the retention of the flowability of SCC at the point of discharge at the job site. Mixture proportions for SCC differ from those of ordinary concrete, in that the former has more powder content and less coarse aggregate. Moreover, SCC incorporates high range water reducers (HRWR, superplasticisers) in larger amounts and frequently a viscosity modifying agent (VMA) in small doses. The questions that dominate the selection of materials for SCC are: (i) limits on the amount of marginally unsuitable aggregates, that is, those deviating from ideal shapes and sizes, (ii) choice of HRWR, (iii) choice of VMA, and (iv) interaction and compatibility between cement, HRWR, and VMA.

SCC mixes must meet three key properties [2]:

1. Ability to flow into and completely fill intricate and complex forms under its own weight.
2. Ability to pass through and bond to congested reinforcement under its own weight.
3. High resistance to aggregate segregation.

There have been a large number of studies on CFT columns with normal and high-strength concrete, there has been relatively little research on CFT columns with self-compacting concrete (SCC) [3]. Han et al. [4] indicated that the load carrying capacity and failure modes of CFT columns filled with SCC and with NC were very similar if the concrete strength is close.

According to Shams and Saadeghvaziri, Schneider and Shanmugam and Lakshmi as cited in reference [5], only the circular CFT columns present this gain of load capacity due to confinement effect. The plane portions of the steel tube of the square sections are not rigid enough to resist the internal pressures due to the expansion of the concrete core; therefore, only the concrete in the center and in the corners of the cross section are effectively confined.

The available studies on the confinement in CFT columns also show that the confinement is more effective when the steel tube is filled with concrete of ordinary compressive strength (OSC), due to its higher deformation capacity in comparison with the high strength concrete (HSC). For HSC filling the CFT columns, O'Shea and Bridge [6] showed that the confinement effect leads to ductile behavior of the composite column, but with a low increase of load capacity.

The L/D ratio affects the confinement degree and the load capacity, and Vrcelj and Uy, Zeghiche and Chaoui, Gupta et al. as cited in reference [5] concluded that both decrease when the L/D ratio is increased.

For column with a high L/D ratio, the failure is characterized by lateral instability with low deformation and before the mobilization of the confinement. Test results have shown that slender columns do not present any gain of resistance due to confinement effect [5].

Properties of Fresh SCC

The main characteristics of SCC are the properties in the fresh state. SCC mix design is focused on the ability to flow under its own weight without vibration, the ability to flow through heavily congested reinforcement under its own weight, and the ability to obtain homogeneity without segregation of aggregates.

Numerous efforts have been explored for new testing methods on SCC in the past decade. There are several organizations that collect the work in this area. ACI Committee 237 Specification and Guidelines for Self-Compacting Concrete [7], EFNARC (2002) [8], and EFNARC (2005) [9] are good examples. Symposiums and workshops on this topic were given by these organizations and several test methods on the flowability of SCC have been popularized since then.

The Slump Flow Test

This is a test method for evaluating the flowability of SCC, where the slump flow of SCC with coarse aggregates having the maximum size of less than 19 mm is measured.

When the slump cone has been lifted and the sample has collapsed, the diameter of the spread is measured rather than the vertical distance of the collapse as shown in Fig. 1. The average of the diameter of flowing is 730 mm which is within the limits set by EFNARC (600-850 mm) [8].



Figure. 1 Slump flow test measurement

T₅₀ Test

A test method for evaluating the rate of filling of SCC, where the 500 mm flow reach time is measured in the slump flow test above. SCC should give $T_{50} = 2 - 5$ seconds [10]. Here, the time was 4 seconds.

L-Box Test

The passing ability is determined using the L- box test as shown in Fig. 2. The vertical section of the L-Box is filled with concrete, and then the gate lifted to let the concrete flow into the horizontal section. The height of the concrete at the end of the horizontal section is expressed as a proportion of that remaining in the vertical section (H_2/H_1). This is an indication of passing ability. The specified requisite is the ratio between the heights of the concrete at each end or blocking ratio to be 0.8 – 1.0. Here the ratio was 1.0 which is satisfying the requirements.



Figure. 2 L-Box test

V-Funnel Test

A test method for evaluating both the filling ability and the material segregation resistance of SCC, using a funnel, as shown in Fig. 3, where the efflux time of SCC with coarse aggregates having the maximum size of less than 19 mm is measured. The flow time for all of the concrete to exit the funnel is recorded as a measure of filling ability. The flow time was 7 seconds which is less than 10 seconds. To measure segregation resistance, the V-funnel is refilled with concrete and allowed to sit for 5 minutes. The door is again opened and the flow time is recorded. The greater the increase in flow time after the concrete has remained at rest for five minutes, the greater will be the concrete's susceptibility to segregation. Further, non-uniform flow of concrete from the funnel suggests a lack of segregation resistance [9]. Here 11 seconds in the second phase and the flowing is uniform which prove that segregation is not expected to happen.



Figure. 3 V-funnel test

Composite Columns Test

A total of 6 test specimens were constructed and tested under concentric axial compression loads. All the specimens are of 160 mm diameter (D). Two of specimens were of length 400 mm (L) to reduce the end effects and to ensure that the specimens would be stub columns with minimum effect from slenderness. Other two are of length 1000 mm that to study the effect of medium slenderness and the other two are of 1500 mm to see the effect of high slenderness. Each tube was welded to a square, steel base plate of 5 mm thickness at the bottom. The SCC for filling in the steel tube columns were mixed first, and then the CFT columns were cast. Meanwhile, the corresponding SCC specimens of nine 150 mm cubes were cast for concrete strength tests.

The specimens are presented in Table 1, where, D is the outside diameter of the circular steel tubes; t is the wall thickness of steel tube; L is the length of the specimen and is chosen to be variable. In the table, the specimen label is including: “S” denotes short CFT columns, “M” denotes medium-length CFT columns and “L” denotes long CFT columns.

In addition to summary of the specimens information are given in Table 1, the experimental ultimate loads are included. The mix designs of SCC are given in Table 2. For the specimens where the load is applied to the entire section, another square steel cover plate of 5 mm in thickness was placed to the top surface of the steel tube. This was done to ensure that the load was applied evenly across the cross-section and simultaneously to the steel and concrete core. To study the effect of rigidity of the cover plate, very rigid plate was also placed.

Then the column specimens were placed directly into the testing machine for compression tests as shown in Fig. 4. A typical column test layout and instrumentation location is shown in Figs. 5 and 6. The concentric loads were applied on the specimens

through the steel-bearing plate. Several strain gauges were used for two CFT specimens to measure the variation of strains at the mid-height of the specimen. Six electrical strain gauges were placed on the exterior surfaces of both the short and long columns to measure the vertical deformations and the perimeter expansion of the steel tubes in the mid-height region at symmetric locations, as shown in Fig. 6. Dial gauges were used to measure the axial deformation.

The experimental study was to determine not only the maximum load-bearing capacity of the composite specimens subjected to axially local compression, but also to investigate the failure pattern up to the ultimate load. All the tests were performed on a 2500 kN capacity testing machine.

The specimens were loaded continuously until failure. A load interval of less than one-tenth of the estimated carrying load capacity was used. The progress of deformation, the mode of failure and the maximum load taken by the specimens were recorded.



Figure. 4 Test for intermediate column

Table 1 Summary of the specimen information.

Specimen No.	$D \times t \times L$	L / D	F_y (MPa)	f_{cu} (MPa)	P_e (kN)
S1	$160 \times 2.8 \times 400$	2.500	368	30	1370
S2					1420
M1	$160 \times 2.8 \times 1000$	6.250			1300
M2					1370
L1	$160 \times 2.8 \times 1500$	9.375			1210
L2					1260

Table 2 SCC mix design.

Cement (kg /m ³)	Sand (kg /m ³)	Gravel (kg /m ³)	Water (kg /m ³)	Super-plasticier
470	868	841	155	1.4%

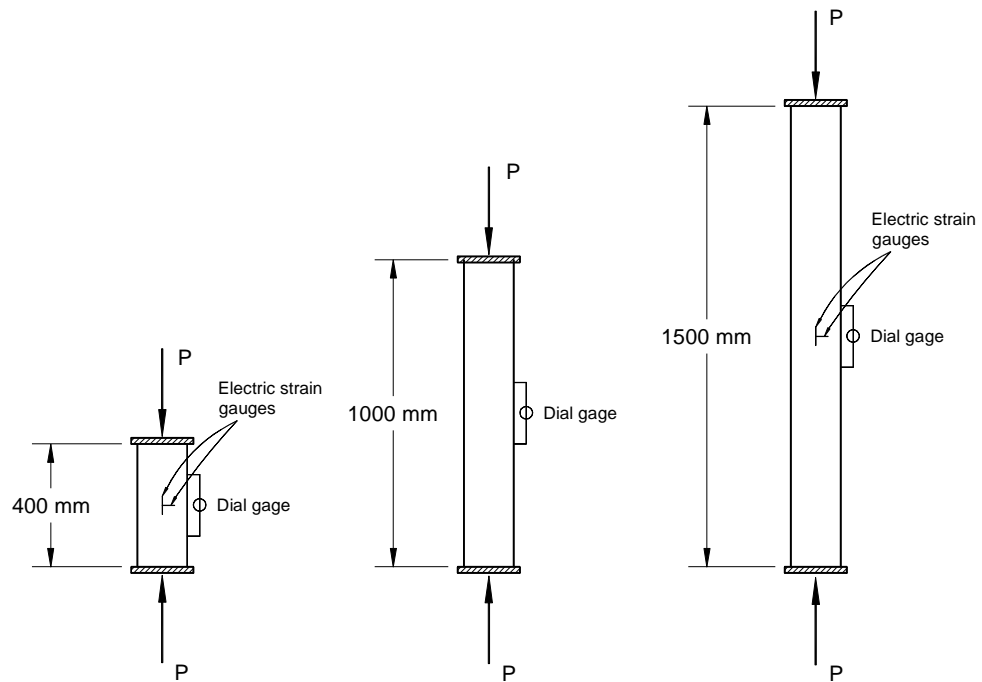

Figure. 5 Test layout

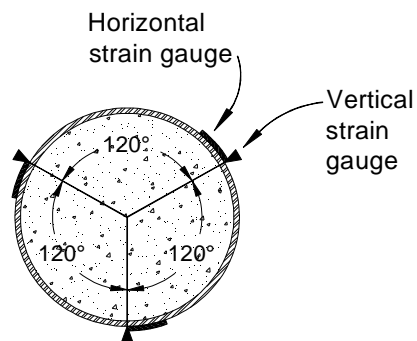

Figure. 6 Strain gauges distribution

Two types of end plate at the top end of specimens were used. Plate with 5 mm thick and other with 25 mm were laid for each type of specimen. It was found that the tested CFT columns under compression generally exhibited in a ductile manner, and the longitudinal force carried by the steel tube increased with the increase of the top endplate rigidity.

It can be found that, the deformation of the top part of steel tube becomes more obvious for the specimens with thicker endplate. However, the thinner top endplate under the bearing plate was falling evidently, and for the specimens with bigger local compression area ratio, the buckle of the steel tube focused on the position near the top endplate, as shown in Fig. 7.



Figure. 7 Failure of the short column.

As can be seen from Fig. 8, larger slenderness ratio leads to a smaller peak load. The shortest columns have attained their section capacities, whilst those slenderest columns only attained 85.7% of their section capacities. It is thus expected that slenderness reduction factors should be applied in designing slender CFT columns.

The failure mode of the specimens was a function of the L/D ratio. The short columns ($L/D = 2.5$) failed due to the crushing of the concrete core, aggravated by local buckling of the steel tube after having reached the yielding stress of the steel.

The columns of $L/D = 2.5$ reached a strain of about 6%, as shown in Fig. 9. Specimens with $L/D = 6.25$ and 9.375 , presented global instability (see Fig. 10) and the failure occurred at axial strain lower than specimens with lower L/D ratio. As in Fig. 5.2 the strain reached for $L/D = 9.375$ is approximately 3% which is half the value for short column.

It was also observed that the load-strain curve changed after the specimens reached the yielding strain of the steel tube (1.7%). All strain gauges placed to measure axial strain obtained values higher than 1.7% at the peak load. This seems to indicate the beginning of the local buckling process for the short columns ($L/D = 2.5$) and the global instability for the columns with $L/D = 9.375$.

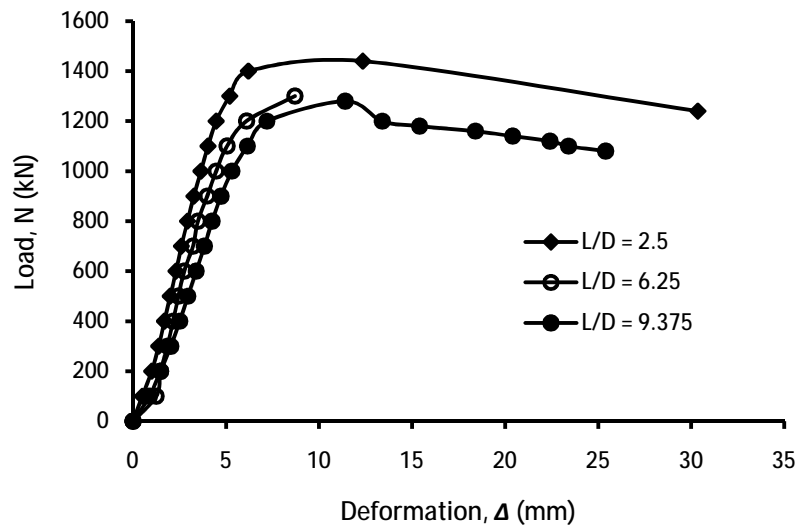

Figure. 8 Load-deformation behavior

The specimens with $L/D = 9.375$ exhibited insufficient lateral strain for mobilizing the confinement effect. This was verified by the three strain gauges placed outside around the column. The lateral strain measured was about 1.5% for the columns with $L/D = 9.375$ and 5% for the short columns at the peak load.

From Fig. 11 it can be noted that in the early stages of loading that minor changes in the strain ratio (lateral to axial) recorded, but a dramatic change occurred after strain yield reached. This may be due to that in the early stages of loading, Poisson's ratio for concrete is lower than that for steel, and the steel tube has no restraining effect on the concrete core. As the longitudinal strain increases, Poisson's ratio of concrete which is 0.15–0.2 in the elastic range increases to 0.5 in the inelastic range [11]. Therefore, the lateral expansion of uncontained concrete gradually becomes greater than that of steel. A radial pressure develops at the steel–concrete interface thereby restraining the concrete core and setting up a hoop tension in the tube. At this stage, the concrete core is stressed triaxially and the steel tube biaxially, so that there is a transfer of load from the tube to the core, as the tube cannot sustain the yield stress longitudinally in the presence of a hoop tension. The load corresponding to this mode of failure can be considerably greater than the sum of the steel and concrete, but shear failure may intervene before the load transfer is complete [11]. Fig. 11 is not showing the first points because of accuracy problems.

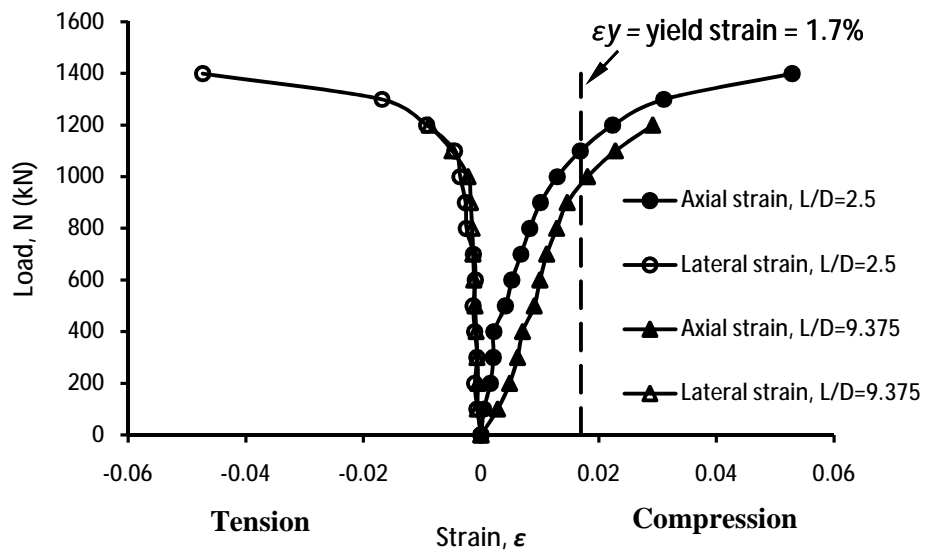

Figure. 9 Load-strain relationship



Figure. 10 Failure of the long column

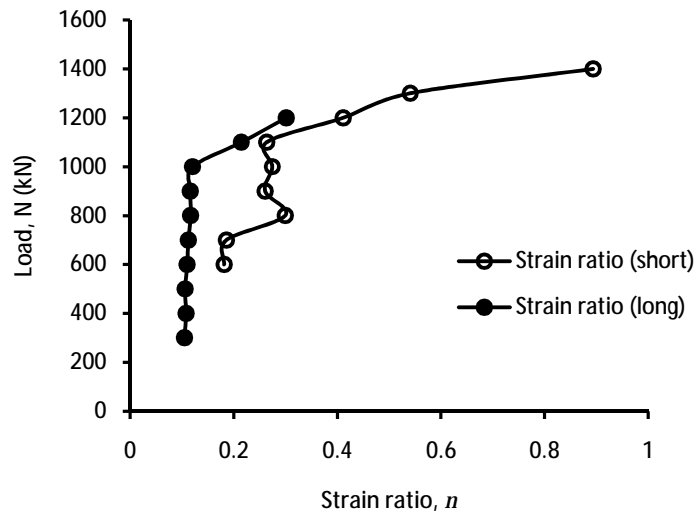

Figure. 11 Load-strain ratio relationship

Conclusions

In this experimental investigation, six-tube CFT columns were investigated and the ultimate static load-carrying capacity was evaluated. On the basis of these results, the following general conclusions were obtained:

- Experimental results on the basis of 6 specimens indicate that the compression force capacity is affected by slenderness ratio of the column. The load capacity decreased gradually with an increase in the slenderness ratio. It is found that the load capacity of $L/D = 9.375$ reached 85.7% of that of $L/D = 2.5$ column. Therefore, slenderness reduction factors should be applied in designing slender CFT columns.
- Under axial concentric loading, short columns get to strains much more than that for slender columns.
- The deformation of the top part of steel tube becomes more obvious for the specimens with thicker endplate. However, the buckle of the steel tube focused on the position near the top endplate.
- The confining effect of the steel tube to the concrete core in the longitudinal elements on the load side was found to take effect after the specimen entered the inelastic phase.
- The shape of failure is different. For slender column the overall buckling was observed while for the short columns the crushing and the local buckling is the dominant failure shape.
- Self-compacting concrete was of big use in filling steel tubes without need to vibrating and decrease the probability of segregation or bleeding.

- The specimens with $L/D = 2.5$ showed a higher increase of load capacity due to the confinement effect, up to the crushing of the concrete core and the local buckling of the tube. The specimens with $L/D = 9.375$ presented a lower strain, since the global buckling occurred before the concrete core could develop its full capacity, reducing the radial deformation of the concrete core and avoiding the mobilization of the confinement effect of the tube. This was verified by the three strain gauges placed outside around the column. The lateral strain measured was about 1.5% for the columns with $L/D = 9.375$ and 5% for the short columns at the peak load.
- It was also observed that the load-strain curve changed after the specimens reached the yielding strain of the steel tube (1.7%). All strain gauges placed to measure axial strain obtained values higher than 1.7% at the peak load. This seems to indicate the beginning of the local buckling process for the short columns ($L/D = 2.5$) and the global instability for the columns with $L/D = 9.375$.

References

- [1] Roeder, C.W., Lehman, D.E., and Bishop, E., "Strength and stiffness of circular concrete-filled tubes," J. Struct. Eng., 136 (12), 1545-1553, 2010.
- [2] Ouchi, M., Nakamura, S-a., Osterson, T., Hallberg, S-E., and Lwin, M., "Applications of self-compacting concrete in Japan, Europe and the United States," ISHPC, 2003.
- [3] Yu, Z-w., Ding, F-x., and Cai C.S., "Experimental behavior of circular concrete-filled steel tube stub columns." Journal of Constructional Steel Research, 63, 165–174, 2007.
- [4] Han, L-H., and Yao, G-H., "Experimental behaviour of thin-walled hollow structural steel (HSS) columns filled with self-consolidating concrete (SCC)." Thin-Walled Structures, 42(9),1357–77, 2004.
- [5] de Oliveira, W.L.A., De Nardin, S., de Cresce El Debs, A.L.H., and El Debs, M.K., "Influence of concrete strength and length/diameter on the axial capacity of CFT columns," Journal of Constructional Steel Research, 65, 2103-2110, 2009.
- [6] O'Shea M.D., Bridge R.Q., "Design of circular thin-walled concrete filled steel tubes," J Struct. Engng. ASCE, 126(11),1295–303, 2000.
- [7] ACI 237R-07, "Self-Consolidating Concrete," Farmington Hills, MI 48331, U.S.A.
- [8] EFNARC, "Specification and Guidelines for Self-Compacting Concrete", 2002, 36pp, <http://www.efnarc.org/>.
- [9] EFNARC, "The European Guidelines for Self-Compacting Concrete: Specification, Production and Use," 2005, 68pp.
- [10] Kilpatrick A, Taylor T., "Application of Eurocode 4 design provisions to high strength composite columns," Composite Construction - Conventional and Innovative, Innsbruck, Austria, p. 561–6, 1997.
- [11] Kuranovas, A. and Kvedaras, A.K., "Behaviour of hollow concrete-filled steel tubular composite elements," Journal of Civil Engineering and Management, Vol. XIII, No 2, 131–141, 2007.