

A Computer Program for Calculating the Circular Product Dimensions During Deep Drawing Operations Steps

Ridha Alwan Ahmed

Engineering College, University of Al-Mustansiriya /Baghdad

Email:ridha_sjmo@yahoo.com

Received on: 20/6/2012 & Accepted on: 9/5/2013

ABSTRACT

Deep drawing process is an important industrial processes where it has been extensively used. It is a process for converting the blank metal to make cylindrical-shape in most of the cases. A research program for performing basic calculations related to the product shape was utilized. Eighteen geometric shapes have been selected for the production in this process. The program is include the general equations for this controlling process for each form. When choosing one of the shapes in the program, the dimensions of the desired product are selected. In other words, the inputs to the program are the required dimensions of the product before reaching the required deformation. In addition, diameter, height and other related dimension are computed which were chosen for each stage throughout the operation. Visual Basic language was used to implement this program because of its ability to deal with graphical interface. The program also accounts for a large number of mathematical equations. Computer program is aimed to help designers templates deep drawing quickly through the implementation of the process, and this exceeds the designer experience that is required to perform the require calculations.

Keywords: Deep Drawing, Deep Drawing Calculations, Deep Drawing Program.

برنامج حاسوبي لحساب أبعاد المنتج الدائري خلال مراحل عملية السحب العميق

الخلاصة

عملية السحب العميق هي واحدة من العمليات الصناعية الواسعة الانتشار حيث يتم فيها تحويل شكل المعدن المبسوط إلى الشكل الاسطواني في اكثر الاحيان. تم في هذا البحث تصميم برنامج يقوم بإجراء الحسابات الأساسية التي تتعلق بشكل المنتج أثناء هذه العملية. تم اختيار (١٨) شكل هندسي يمكن إنتاجها بهذه العملية وتم تضمين البرنامج المعادلات العامة لهذه العملية والمعادلات الخاصة التي تحكم كل شكل من هذه الأشكال. عند اختيار احد الأشكال الموجودة في البرنامج يتم إدخال أبعاد المنتج المطلوب الحصول عليه يقوم البرنامج بحساب الافراد للمنتج وعدد المراحل التي يمر بها المنتج قبل الوصول إلى المنتج بإبعاده المطلوبة وكذلك قطر وارتفاع المنتج وأبعاد أخرى تخص الشكل المختار لكل مرحلة من المراحل التي يمر بها المنتج. تم استخدام لغة (Visual Basic) لتنفيذ هذا البرنامج لما تمتلكه من إمكانية التعامل مع واجهة الرسم. يقوم البرنامج بإجراء الحسابات لعدد كبير من المعادلات الرياضية.

يهدف البرامج إلى مساعدة مصممي قوالب السحب العميق من خلال تنفيذ حسابات عملية السحب العميق بكل دقة وسرعة، وكذلك يتم تجاوز خبرة المصمم والتي تكون مطلوبة لإجراء هذه الحسابات.

INTRODUCTION

Deep drawing process is one of the most important engineering processes used in the present time. Now a day more and more engineering parts are using manufacturing processes, which is very economical. This includes the formation of the metal piece to the desired shape in deep drawing dies by the pull forces using the pistons (press).

In Many cases, where deep drawing process is used for mass production, a cost reduction is achieved. This is the most important purpose for the deep drawing process. This is accomplished by maintaining the mechanical properties of the metal that Process occurs without heating the metal.

From common examples of products of deep drawing is the hulls of the cars and home equipment devices and sub-equipment products in the devices.

LITERATURE REVIEW

The sheet metal deep drawn technology is one of the most challenging process in manufacturing. Sizes, shapes, thickness and deep drawn metal were used to produces sheet metal deep drawn parts covering a diverse range of variables. Individual variables should be evaluated carefully to determine the optimum process method.

Tisza's work [1] described a modular "CAD- CAM" system. In the method, a deep drawing process sequences were developed to design tools for the manufacture of sheet-metal components. These will have an axisymmetric and rectangular cross-sections.

Xiao et al. [2] set up the expert system in designing the axisymmetric deep drawing parts. The system can be suited to the planning process of general drawing and to the strip progressive drawing of axisymmetric parts.

Zhu et al. [3] developed an expert system for the process of planning of the axisymmetric deep drawing. The whole program was coded in "C" language.

Altan et al. [4] developed the Axisymmetric Sequence Forming Expert System (ASFEX) for axisymmetric parts, produced by deep drawing.

Huh & Kim [5], have applied inverse finite element (FE) analysis. The aim is to estimate the initial blank shape, intermediate deform shape, thickness distributions and failure during multistage deep drawing operation of elliptic cup. The results show that the localized deformation occurs along the major axis of the elliptic cup. The wrinkling occurs along the minor axis, the modified design improved the quality of drawn part and thus reducing the possibility of failure occurrence.

Park et al.[6] developed a computer-aided process planning system for rotationally symmetric deep drawing products.

Zhang et al. [7] developed a computer-aided process planning for multi-stage, non-axisymmetric sheet metal deep drawing using a case-based reasoning (CBR) approach.

DEEP DRAWING DIES

The deep drawing process can be started with a flat metal. This will be converted it into cup shape by pressing the sheet in the center with a circular punch fitting into a cup shaped die. It is widely used in many industrial fields such as automotive and packing industries. If the depth of cup is more than half its diameter, the process is termed as deep drawing and with a lesser depth to diameter ratio. It is called "shallow

drawing”. Parts of various geometries and shape are made by drawing process. The deep drawing process is illustrated in Figure (1) [8].

During the drawing process, the sheet metal part is subjected to a complicated pattern of stress. The portion of the blank between the die wall and punch surface is subjected to pure tension. Whereas the portion lower down near the bottom is subject both to tension and bending. The portion of metal blank, which forms the flange at the top of the cup is subjected to circumferential compressive stress and buckling and becomes thicker as a result thereof.

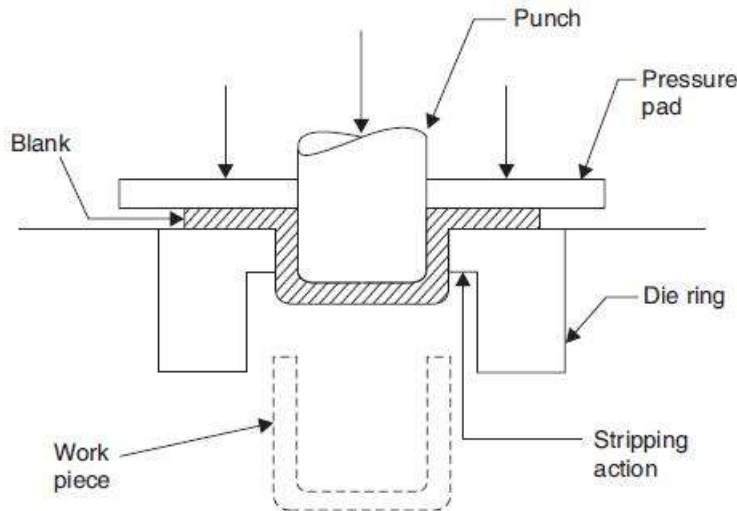

Figure (1) Deep drawing process [8].

The flange has therefore to be held down by a pressure pad, otherwise, its surface will become buckled and uneven like an orange peel.

Deep drawing is a difficult operation and the used material should be specially malleable and ductile, otherwise it will crack under the induced stresses. The wall thickness of a deep drawn component does not remain uniform. The vertical walls become thinner due to tensile stresses. But the thinnest portion is around the bottom corner of the cup all around. This thinning of sheet at these locations is called “necking”.

After deep drawing, the component may be subjected to certain finishing operations like “ironing”, the object of which is to obtain more uniform wall thickness.[8]

Drawing Ratio

One of the measures of the severity of a deep drawing operation is the drawing ratio (r). This is easily defined for a cylindrical shape as the ratio of blank diameter (D) to punch diameter (d) [9]. Thus:

$$r = \frac{D}{d} \quad \dots(1)$$

The drawing ratio provides an indication for the severity of a given drawing operation. The greater the ratio, the more severe the operation. The upper limit on the drawing ratio is approximated to a value of 2.0 [7]. The actual limiting value for a given operation depends on many variable such as punch and die corner radii (Rp and

Rd), friction conditions, depth of draw, and other characteristics of the sheet metal (e.g., ductility, degree of directionality of strength properties in the metal).[9]

Another way to characterize the given drawing operation is by the reduction (R), where:

$$R = \frac{D-d}{d} \quad \dots (2)$$

It is very closely related to drawing ratio. The value of reduction (R) should be less than 0.50 [9].

Maximum percentage of reduction.

It is generally accepted the value of deep-drawing materials reduction of various thicknesses is slightly higher than the values included previously in equation (2) . Intermediate annealing is to be utilized only when the shells become strain hardened or when cracks begin to form.[10]

Table (1) gives the values of the maximum possible reduction. It should be used for dies operating in hydraulic presses, where the pressure of the blank holder is constant. The percentages given here are recommended for drawing operations only where no ironing is involved. Should ironing of the shell be needed, the values shown in Table (1) must be reduced.

Table (1) Maximum Percentage of Reduction for Deep-Drawing Materials (for all materials except Stainless-Steel), [10].

Stock thickness mm	First-drawing operation	Second-drawing operation	Any additional drawing operation
0.25	27	18	17
0.38	32	20	19
0.53	35	21	20
0.61	39	22	21
0.79	42	23	22
0.91	44	26	24
1.07	46	28	25
1.17	47	28	25
1.37	47	29	26
1.57–3.15	48	30	27
3.18–6.35	47	28	26

Height of a Shell

The height of the shell consists of a displaced metal taken mainly from the flange and more or less from the other areas of the blank. Where no thinning of walls is encountered, the bottom of the shell remains unaltered, with no metal being removed or added there.

The maximum height attainable from a given blank size can therefore be calculated. For the purpose of simplicity this evaluation is approximate, where the corner radii are neglected and the shell thickness is considered equal to that of the blank in all its cross sectional areas. In such a case, the height will be: [10]

$$h = \frac{D^2 - d^2}{4d} \quad \dots (3a)$$

Where:

h = height of shell

D = blank diameter

d = mean diameter of shell

The height of a shell subjected to n -redrawing operations may be calculated: [10]

$$h_n = \frac{t(D^2 - d_n^2)}{4d_n t_n} \quad \dots (3b)$$

Obviously, d_n is the mean diameter of the shell after n -redraw and t_n is the thickness of the wall then, while t is the original thickness of the blank. [10].

Drawing of Cylindrical Shells

A generally accepted definition of deep drawing is that the drawn part's or cup's length is greater than half its diameter. At such a difference from the flat blank, one can anticipate the changes that must occur within the material structure to bring about this extension of shape.

Drawing of round shells seems simple enough, yet the amount of influencing factors renders this operation no less difficult than any other drawing process. Already the fact that a blank of a correct size will come out of the drawing process with wavy edges (in flangeless shells) and often has to be trimmed to certain height, brings about a host of dilemmas pertaining to the trimming method and its control. Where a flange has to remain on the drawn cup, other problems, such as those of flange retention, trimming, and ejecting of parts, may be encountered.

First of all, the blank size must be addressed with care and often several calculations must be performed and supported by testing, before the final drawing tool can be constructed.[10].

Blank Size of a Drawn Shell

The displacement of metal in drawing operations varies along the shape of a shell. The flange is subject to the greatest alterations, while the bottom remains almost unchanged.

The metal flow during the drawing process promotes the increase in height of a part toward which it is applied. Whole segments shift away from the flange area into the body of the shell. The surface most affected by such changes is that located farthest away from the shell body, which is the outer surface of the flange.

To calculate the basic size of a blank from which through such transformation—a drawn cup may be obtained, the area of the part has to be assessed, which then will be projected into a diametric size of the blank.

Two methods of blank calculation, both applicable only to symmetrical shells, are described further. The first method is based on a theory that the area of any shape is given by the length of its profile, multiplied by the length of travel of its center of gravity.[10]

First Method of Blank Calculation: [10]

Lengths of line segments L_1 , L_2 , and L_3 , as shown in Figure (2) should be assessed along their neutral axis. Distances of their centers of gravity along X axis,

X1, X2, X3 should be established. The formula to calculate the linear distance of the center of gravity (CG) of the shape is:[10]

$$X = \frac{L_1 X_1 + L_2 X_2 + L_3 X_3}{L_1 + L_2 + L_3} \quad \dots (4)$$

As there is no need to calculate the distance of the center of gravity CG along the Y axis, it will not be attempted here.[10]

The total length of the shape can be obtained by adding all segment lengths together. Multiplying this value by the length of the circular path of the CG can be done by using the formula:

$$A = 2\pi X(L_1 + L_2 + L_3) \quad \dots (5)$$

From the result, a blank diameter may be acquired:

$$D = 2\sqrt{\frac{A}{\pi}} = \sqrt{8XL_{total}} \quad \dots (6)$$

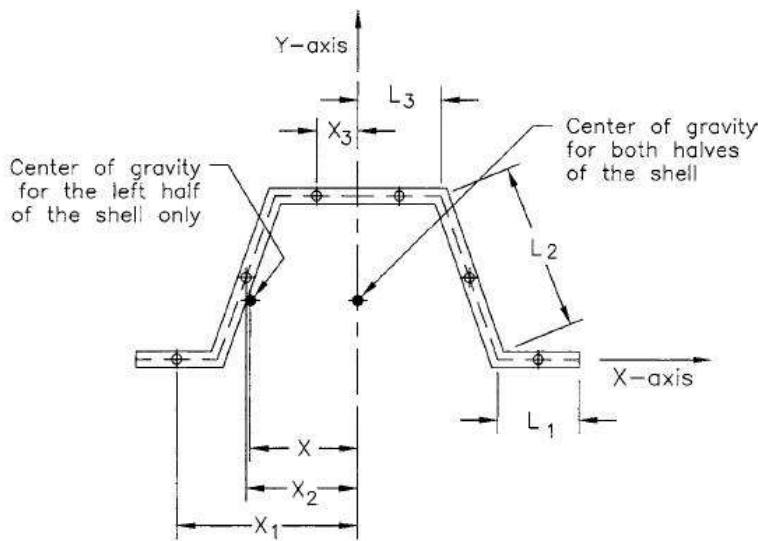

Figure (2) First method of blank calculation.

Second Method of Blank Calculation

The second method of blank computation calculates each section of the drawn shell separately, adding their lengths up Figure (3).

Both of these methods give only an approximate size of the blank diameter, since to calculate its exact proportions is nearly impossible. Too many variables influence the drawing process, making it more complex than any other manufacturing method. The movements of metal, which may produce thickening or thinning of various sections, a possibility of ironing, the variation in height, are a few factors out of many that expose the drawn part to so many influences that the total outcome is unpredictable.

Therefore, the blank size is usually chosen either slightly larger than necessary and trimmed afterward or an exact blank size may be considered, which is further adjusted in size after completion of a trial run.

The following set of calculations considers the size of blank diameter for simple cylindrical

shells to be dependent on the ratio of the shell diameter to the corner radius d/R . It regards the blank to be of the same surface area as the finished shell.

where $d/R = 20$ or more, the formula is:[10]

$$D = \sqrt{d^2 + 4dh} \quad \dots (7a)$$

with $d/R = 15$ to 20 , the following formula should be used:

$$D = \sqrt{d^2 + 4dh} - 0.5R \quad \dots (7b)$$

where $d/R = 10$ to 15 , the formula is

$$D = \sqrt{d^2 + 4dh} - R \quad \dots (7c)$$

And where $d/R =$ below 10 , the calculation becomes

$$D = \sqrt{(d - 2R)^2 + 4d(h - R) + 2\pi R(d - 0.7R)} \quad \dots (7d)$$

Some recommend a formula for calculating all types of drawn shell blanks as:

$$D = \sqrt{d^2 + 4dh - 3.44dR} \quad \dots (7e)$$

where D = blank diameter

d = shell diameter

h = height of shell

R = radius of corner

For shells where some ironing is expected, resulting in thinner walls than the bottom surface, the following blank size calculation may be used:

$$D = \sqrt{d^2 + 4dh \frac{t_w}{t_b}} \quad \dots (8)$$

Where t_b is the thickness of bottom area or that of a blank and t_w is the thickness of wall.

For an evaluation of more complex shell shapes, their cross-sectional outline should be dismembered to obtain simple sections whose areas can be calculated with the aid of formulas in Figures(4 and 5). The total blank size is obtained by adding up all results.

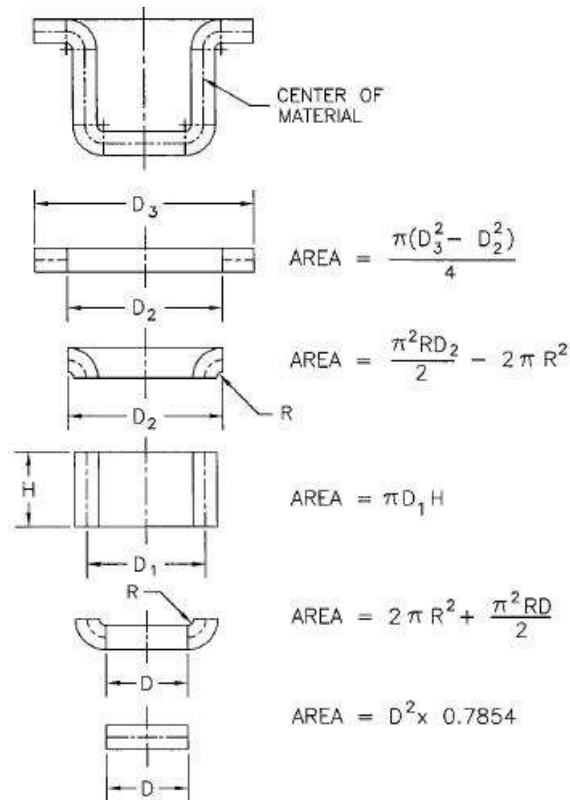

Figure (3) Second method of blank calculation.

Radius of Drawing Punch and Die

As already mentioned, the radius of the die section should be quite liberal in size. However, too large radii are not desirable either, as they enhance the material's tendency to wrinkle and fold.

The basic recommended sizes of tooling radii for drawing punches and dies are:

First drawing die radius: $(6 \text{ to } 10)t$

Redrawing die radius: $(6 \text{ to } 8)t$

Drawing punch values differ with the diameter of shell d as follows:

For $d = [6.3 \text{ to } 100 \text{ mm}]$, $RP = (3 \text{ to } 4)t$

For $d = [100 \text{ to } 200 \text{ mm}]$, $RP = (4 \text{ to } 5)t$

For $d = \text{above } [200 \text{ mm}]$, $RP = (5 \text{ to } 7)t$

The size of the punch radius is further influenced by the depth of the draw, percentage of reduction, and type of metal. [10]

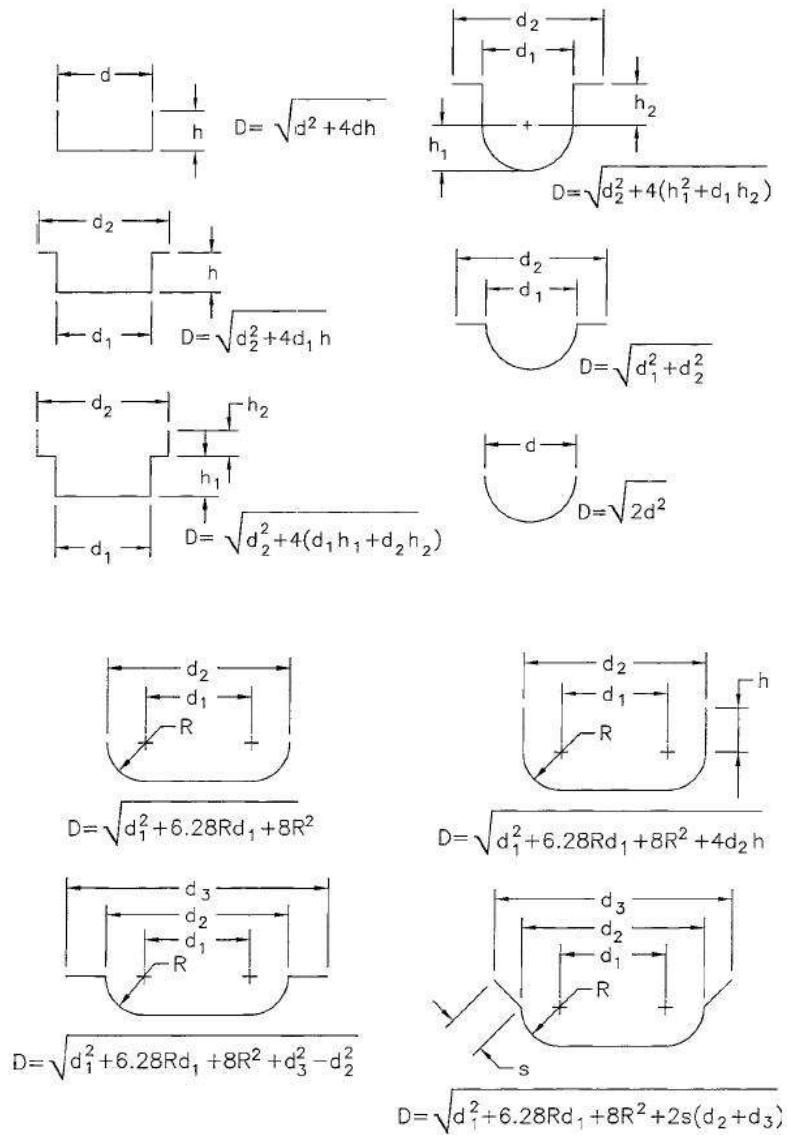

Figure (4-a) Blank diameter calculation.

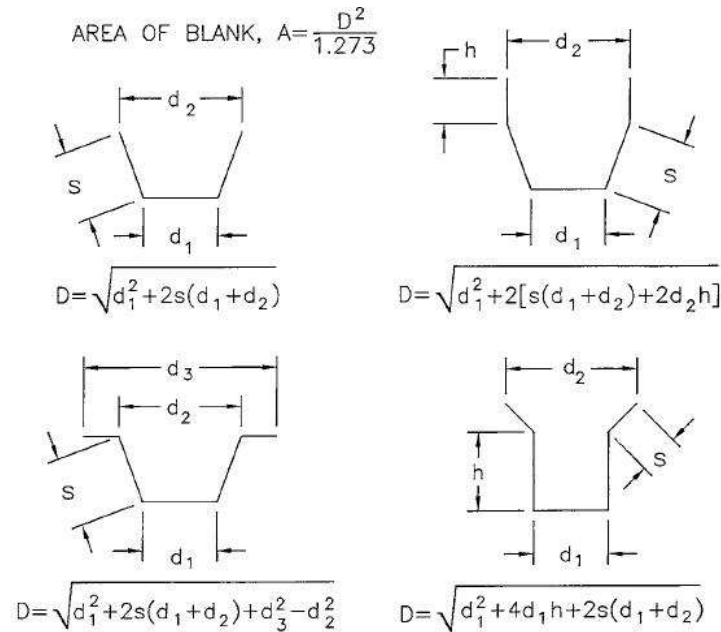

Figure (4-b) Blank diameter calculation.

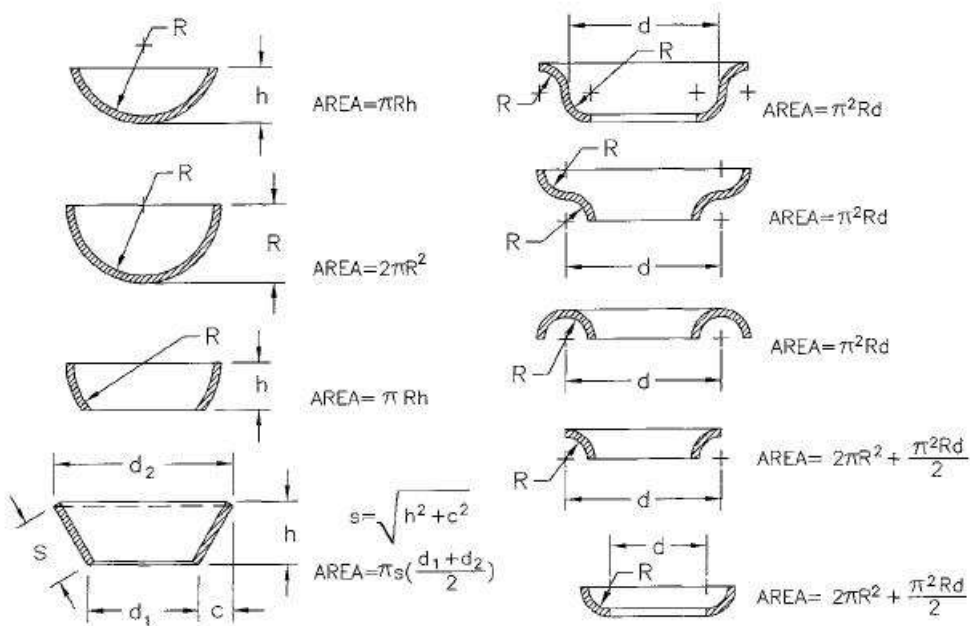

Figure (5) Areas of drawn shells through center of stock.

BUILDING PROGRAM

Building program is based on the mutual interaction between the user (designer) and all of steps of the proposed program and a graphic software, so it has been the adoption of Visual Basic programming language to build the program and that for the many possibilities which Provided by these Language Including the freedom to design interfaces required for the prepared program and flexibility in Mathematical treatments procedure Moreover it is one of the methods of modern programming that

they can gain access to programs Compatible With the operating system (Windows) and the possibility of linking with The other Software , and were also Adoption Drawing program (AUTOCAD) To accomplish the geometric graphics for shapes that were completed the Design calculations, because it is one of the most graphic software Depending As well as to take advantage of its Wide potential In the drawing. Drawings were completed in the form of a lump product.

Stages of building the program

Building program was divided into three basic stages. The first stage is the Selection Shapes process , the Second stage Is to determine the mathematical equations relating to each shape, the third stage which are based on Previous stage Is the interface design of each shape, which includes input and output variables which differ from one shape to another.

Selection Geometric shapes process

There are a large number of geometric shapes Which can be obtained Using Deep drawing templates and these shapes differ in the degree of complexity can be manufactured according to the components of the shape of the geometric pieces, Mismatch the few complex, the medium, and the more complex and Increased Components of the shape of the geometric pieces We will need to long and complex mathematical operations so that it is entered into the Programming process To get the correct results from the program. Was chosen more standard shapes available in the scientific resources so that the number of selected shapes (18) geometric shape but we avoided the selection of some of the complex shapes for the difficulty of dealing with it mathematically.

Determine the mathematical equations

The program calculates five stages of each shape. After determining the desired shape, it is First Calculates the blank diameter Required to obtain a specific shape and then determines the number of stages required by this shape and then performs other computations for the geometric shape from diameters And elevations And arches, and any other elements intervene in the formation of the geometric shape.

Designing program interfaces

The program consists of main interface when you open the program it contains program name and a diagram for the process of deep drawing in addition to the names of those who set up this program also an program interface contains the Names list for Geometric shapes That can perform Design calculations for it which as we mentioned (18) shape, the program interface allows Selection one of shapes in the code list after selecting the chosen shape an especially list is open to this shape so we can enter the dimensions of the desired shape wanted to perform its calculations, the program performs execution process of the Design calculations by press the button (Design), and scans all inputs, outputs, and do other entries by pressing the button (Clear).



<p>Beveled Cup With Cylinder</p>  $D = \sqrt{(d_1^2 + 2S(d_1 + d_2) + 2d_2h)}$	<p>Beveled Cup With Flange</p>  $D = \sqrt{(d_1^2 + 2S(d_1 + d_2) + d_3^2 - d_2^2)}$
<p>Beveled Cup</p>  $D = \sqrt{(d_1^2 + 2S(d_1 + d_2))}$	<p>Cup With Beveled Flange</p>  $D = \sqrt{(d_1^2 + 4d_1h + 2S(d_1 + d_2))}$
<p>Cup With Double Flange</p>  $D = \sqrt{(d_2^2 + 4(d_1h_1 + d_2h_2))}$	<p>Cup With Flange</p>  $D = \sqrt{(d_2^2 + 4d_1h)}$
<p>Dish With Beveled Flange</p>  $D = \sqrt{(d_1^2 + 4h^2 + 2S(d_1 + d_2))}$	<p>Dish With Cylinder</p>  $D = \sqrt{(d^2 + 4(h_1^2 + dh_2))}$
<p>Dish With Flange</p>  $D = \sqrt{(d_2^2 + 4h^2)}$	<p>Dish</p>  $D = \sqrt{(d^2 + 4h^2)}$

Figure (6-a) shapes that have been selected with blank diameter for each shape.

<p>Half Sphere With Beveled Flange</p>  <p>$D=1.414\sqrt{(d_1^2+S(d_1+d_2))}$</p>	<p>Half Sphere With Flange</p>  <p>$D=\sqrt{(d_1^2+d_2^2)}$</p>
<p>Half Sphere</p>  <p>$D=\sqrt{(2d^2)}$</p>	<p>Radiused Bottom Cup With Beveled Flange</p>  <p>$D=1.414\sqrt{(d_1^2+2d_1h+S(d_1+d_2))}$</p>
<p>Radiused Bottom Cup With Flange</p>  <p>$D=\sqrt{(d_1^2+d_2^2+4d_3h)}$</p>	<p>Radiused Bottom Cup</p>  <p>$D=1.414\sqrt{(d^2+2dh)}$</p>
<p>Cup</p>  <p>$BS=d/r$</p> <p>$BS < 10 \quad D=\sqrt{((d-2r)^2+4d(h-r)+2\pi(d-0.7r))}$</p> <p>$BS \geq 10 \ \& \ BS < 15 \quad D=\sqrt{(d^2+4dh)}-r$</p> <p>$BS \geq 15 \ \& \ BS < 20 \quad D=\sqrt{(d^2+4dh)}-0.5r$</p> <p>$BS \geq 20 \quad D=\sqrt{(d^2+4dh)}$</p>	<p>Disc With Fillet Edge</p>  <p>$D=\sqrt{(d_1^2+2\pi R d_1+8R^2)}$</p>

Figure (6-b) shapes that have been selected with blank diameter for each shape.

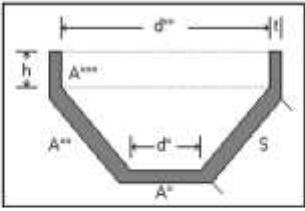
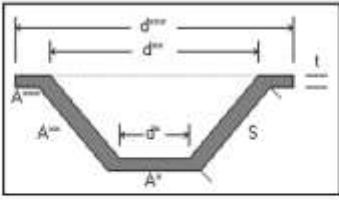
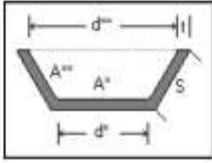
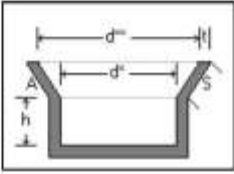
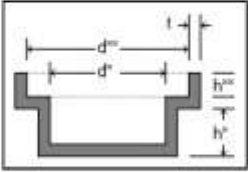
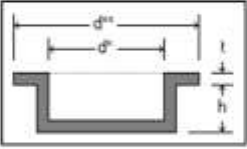
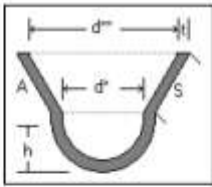
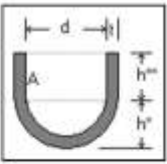
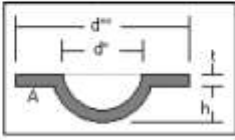
Determinants of program work

As well-known there is determinants of work for each program and the determinants of the work of this program is as follows: -

- 1 - Number of shapes that the program deals with have been identified by (18) shape only
- 2 – Shapes selected in the previous term are all cylindrical shapes and the program does not deal without these shapes.
- 3 - The program can calculate the number of drawing stages for the chosen shape to extent only five stages. FIGURE (7) shows all program interfaces.

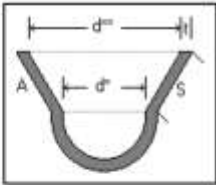
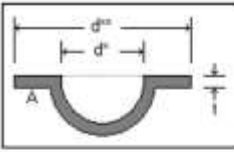
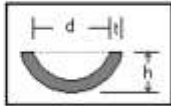
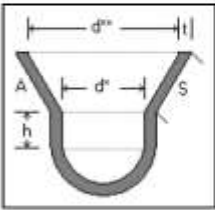
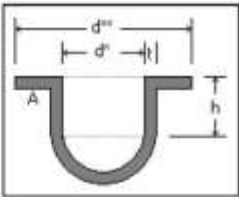
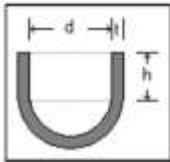
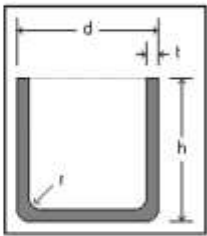
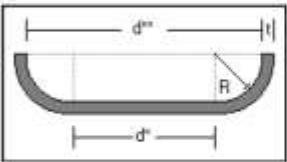
Warning messages

For the purpose of avoiding cases of the wrong input of the dimensions has been restricted implementation of the mathematical development of general conditions for the process of deep drawing, especially in relation to each form included in the program, of the general conditions, for example the introduction of radius of the product smaller than can be achieved in the process of deep drawing in this case, the program implementation accounts show a warning message alerting the introduction of an error in the dimensions.

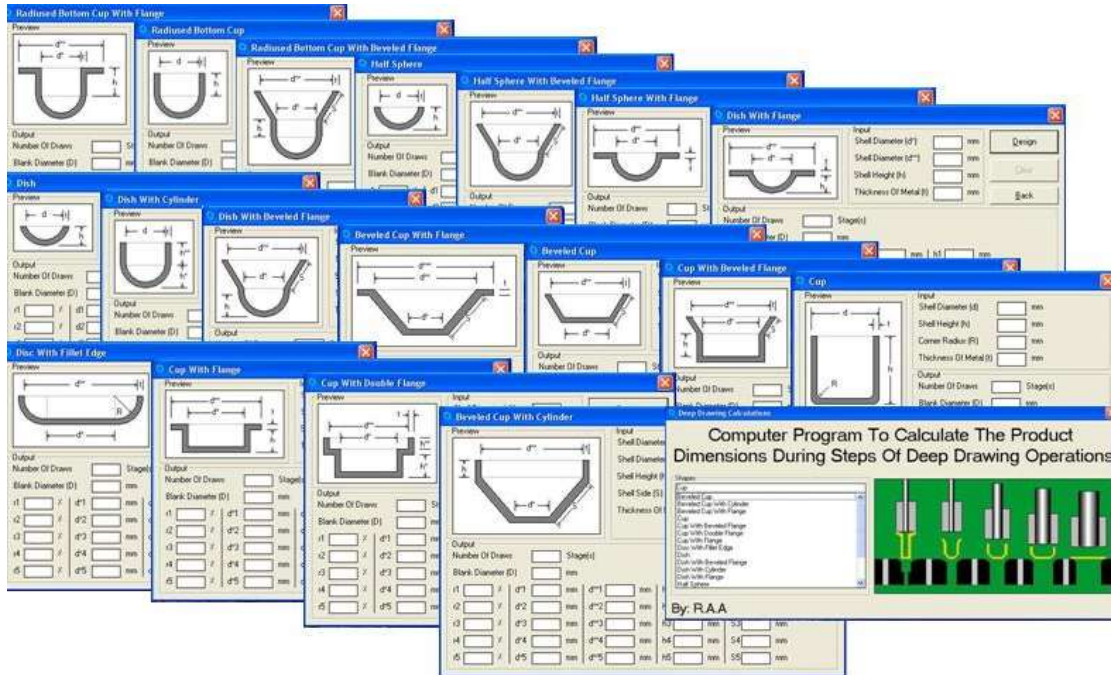

Figure (7) program interfaces.

Special conditions, for example a form may contain more than one diameter. When you enter a value for the small diameter is greater than the value of large diameter will show a warning message also cautions that there a line in the introduction of deportation. Conditions have been developed to implement the mathematical calculations for most shapes in the program so that the no implementation however, verification of these conditions. Figure (8) shows one of the wrong input of the dimensions caused the appearance of the warning message.

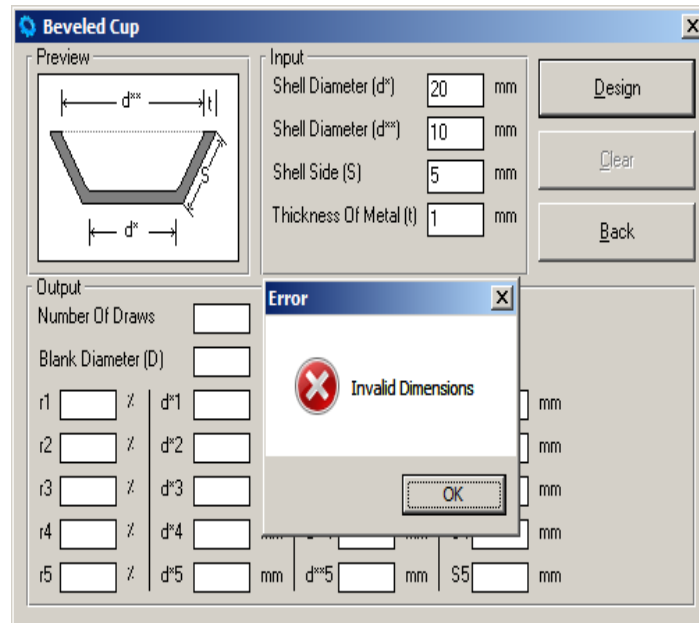

Figure (8) Warning message.

DISCUSSION THE WORK STEPS AND RESULTS

Through the steps followed in this research the following points could be observed:

- 1 - The program work is based on the data of part required to be produced. This include the dimensions of the geometric shape and that the steps of the program based on it. The object is to achieve the required design calculations for which the process of finding the design templates for the needed shape.
- 2 - The program is set up to deal with most geometric shapes. This is the most commonly used in industrial applications. The program provides product itinerary, beginning from the dimensions of the product (blank) down to the final shape of the product.

CONCLUSIONS

- 1- The program can deal with different circular shapes. It included the mathematical calculations for each shape to reach the final product, with no more than five stages.
- 2 - The designer can deal with the program and take advantage of its benefits even if he did not have enough experience about design of deep drawing molds.
- 3- The Consideration Results of the database program can be used to determine the number of required templates to obtain the final shape of the product.
- 4- The program help the designer to increase its accuracy and thus reducing the costs of production.

REFERENCES

- [1]. Tisza, M. "CAD: CAM system for deep drawing processes", *Adv. Tech. Plast.* 1 (1987) 145–152.
- [2]. Xiao, X. S. Chen, G. Wang, J. Xiao," An expert system for process planning for drawing", *Adv. Tech. Plast.* 1 (1990) 545– 549.
- [3]. Zhu, J. X. Wang, X. Ruan," An Expert System for Process Planning of Deep Drawing", *Proceedings of the Fourth ICTP, Beijing, People's Republic of China, 1993*, pp. 1875–1880.
- [4]. Esche, S. S. Khamitkar, G. Kinzel, T. Altan," Process and die design for multi-step forming of round parts from sheet metal", *J. Mater. Process. Technol.* 59 (1996) 24–33.
- [5]. Huh H. Kim S., "Process design for multi-stage elliptic cup drawing with the large aspect ratio", *Journal of Material Processing Technology*, vol 113,(2001),p.779-785.
- [6]. D. H. Park and PKDV Yarlagadda," Computer Aided Process Planning for Non-Axisymmetric Deep Drawing Products in NUMIFORM" – 2004, edited by S. Ghosh et al. , "Numerical Methods in Industrial Forming Processes Proceedings", Columbus, Ohio, 2004, pp. 1985-1988.
- [7]. W.Y. Zhang, S.B. Tor and G.A. Britton," Indexing and retrieval in case based process planning for multi-stage non-axisymmetric deep drawing", *Int. J. Adv. Manuf. Technol.*, 26, 2006, pp.12–22.
- [8]. H.N. Gupta , R.C. Gupta & Arun Mittal , "Manufacturing Processes" 2nd edition , New Age International limited publishers, 2009.
- [9]. Michell P. Groover," Fundamentals of Modern Manufacturing: Materials, Processes and Systems". 4th edition, John Wiley & Sons, Inc, 2010.
- [10]. Ivana Suchy , " Handbook of Die Design", 2nd edition , McGraw- Hill, New York, 2006.