

Experimental and Numerical Study of the Effects of Creating Openings in Existing RC Beams and Strengthening with CFRP

Hayder Qais Majeed

College of Engineering, University of Baghdad / Baghdad

Email: hayderqs@yahoo.com

Received on: 20/11/2011 & Accepted on: 24/6/2012

ABSTRACT

This study presents an experimental and nonlinear finite element analysis of creating square openings in existing RC beams and strengthening with CFRP laminate. Flexural strengthening of reinforced concrete beams is now becoming more and more important in the field of structural maintenance and retrofitting. In the experimental programming, three RC beams were cast. Two beams were tested in the un-strengthened condition the first act as the solid Control beam, and the other have openings, the third one have opening and strengthening with CFRP laminate. The beams were also modeled using a FEM packaged (ANSYS 11). The results indicate that the strengthened beam recorded the highest failure load and its mode of failure was ductile. The numerical results seemed to be able to predict the behavior of the beams.

Keywords: RC beams, Strengthening, CFRP laminate, opening, ANSYS.

الدراسة التجريبية والعديدية لتأثيرات عمل فتحات في الروافد الخرسانية المسلحة وتقويتها بالالياف الكربونية

الخلاصة

يقوم هذا البحث بالدراسة المختبرية وايضا باستعمال التحليل للاختصاصي للعنصر المحددة لتأثيرات الناتجة عن عمل فتحات مستطيلة في الروافد الخرسانية المسلحة بالإضافة الى دراسة تقويتها بالالياف الكربونية. اقيت الروافد الخرسانية المسلحة صبح في الوقت الحاضر أكثر أهمي في حقل الصيانة الهيكلية والترميم. في الدراسة المختبرية, تم عمل ثلاثة نماذج من الروافد الخرسانية المسلحة. النموذج الاول عبارة عن رافدة بدون فتحات تعمل كعتبة سيطرة, اما النموذجين الاخرين فقد تم عمل فتحات عند منطقة القص, احد هذين النموذجين مقوى بالالياف الكربونية. كما تم نمذجة الروافد ايضا باستعمال التحليل للاختصاصي للعنصر المحددة وذلك بواسطة برنامج الانسز (ANSYS 11) بتشير النتائج بأن الرافدة لمقواة سجلت أعلى حمل فشل من نظيراتها بدون تقوية ونمطها في الفشل يكون أكثر مرونة كما بينت النتائج بان الدراسة العديدية قادرة على توقع سلوك الروافد كما انها تعطي نتائج مقارنة للدراسة المختبرية.

INTRODUCTION

In the construction of modern buildings, network of pipes and ducts are necessary to accommodate essential services like water supply, sewage, air-conditioning, electricity, telephone, and computer network. Usually, these pipes and ducts are placed underneath the beam and, for aesthetic reasons, are covered by a suspended ceiling, thus creating a dead space. Passing these ducts through transverse openings in the floor beams leads to a reduction in the dead space and results in a more compact design. Due to abrupt changes in the sectional configuration, opening corners are subject to high stress concentration that may lead to cracking unacceptable from aesthetic and durability viewpoints. The reduced stiffness of the beam may also give rise to excessive deflection under service load. Unless special reinforcement is provided in sufficient quantity with proper detailing, the strength and serviceability of such a beam may be seriously affected. Therefore, in this paper, the study of effect of creating a small openings with depth equal 0.25 the depth of the web and also use of externally bonded carbon fiber reinforced polymer (CFRP) composite sheets to strengthen reinforced concrete (RC) beams containing openings was made by experimental and 3D nonlinear finite element (FE) model, developed using the commercial finite element software, ANSYS. The results are presented in terms of the ultimate load carrying capacity, crack pattern, and deformational characteristics. The comparisons between the FE results and the experimental data demonstrate the accuracy and validity of the FE model. Numerous studies demonstrated the effectiveness of openings and externally bonded CFRP composites to improve the capacity RC beams. The test data reported by [Somes and Corley (1974)] indicated that when a small opening is introduced in the web of a beam, unreinforced in shear, and the mode of failure remains essentially the same as that of a solid beam. However, based on [Mansur's (1992)] findings, as the opening represents a source of weakness, the failure plane always passes through the opening, except when the opening is very close to the support so as to bypass the potential inclined failure plane. [Mansur (1998)] discussed about the effects of introducing a transverse opening on the behavior and strength of reinforced concrete beams under predominant shear. [Abdallaa et al. (2003)] used pre reinforced polymer (FRP) sheets to strengthen the opening region in an experimental program. [Thompson and Pessiki (2006)] conducted an experimental study to investigate the precast, prestressed inverted-tee girders with large web openings. [Soroush et al. (2011)] investigate of the opening effects on the behavior of concrete beams without additional reinforcement in opening region using FEM. [El-Maaddawy et al. (2011)] simulate a reinforced concrete (RC) deep beams with openings strengthened in shear with carbon fiber reinforced polymer (CFRP) sheets using a 3D nonlinear finite element (FE) model. Many experimental and analytical researches have been carried out on rectangular concrete beams with web openings. The researches have provided several practical results. At the present time, many methods for analyzing reinforced concrete members are available. One of the most powerful methods is the finite element technique which spares much time and efforts. Even though many experimental studies have been reported, no research

study has been done on shear and flexure strengthens RC rectangular beams with rectangular opening by simulation.

EXPERIMENTAL INVESTIGATION

Description of Specimens

Three reinforced concrete beams of rectangular cross-sections were tested in this study namely B1, B2, and B3. Out of these, beam B1 was a solid beam without opening left as the un-strengthened control specimen; beam B2 was un-strengthened beam have two square openings with (75mm x 75mm) at a distance of 100mm from the supports and 100mm height from the bottom of the beam as shown in Fig.(1). Beam B3 is similar to beam B2 and strengthened for flexure and shear by CFRP laminate as shown in Figure (2).

Fabrication of Specimens

All beam specimens were of 1,000 mm long, 150 mm wide and 300 mm deep. These beams were reinforced with 2- Φ 10mm steel bars in the tension zone, and 10 mm bars were used for shear reinforcement which was symmetrically placed as shown in Fig.(1). The spacing of the shear reinforcement was 125mm.

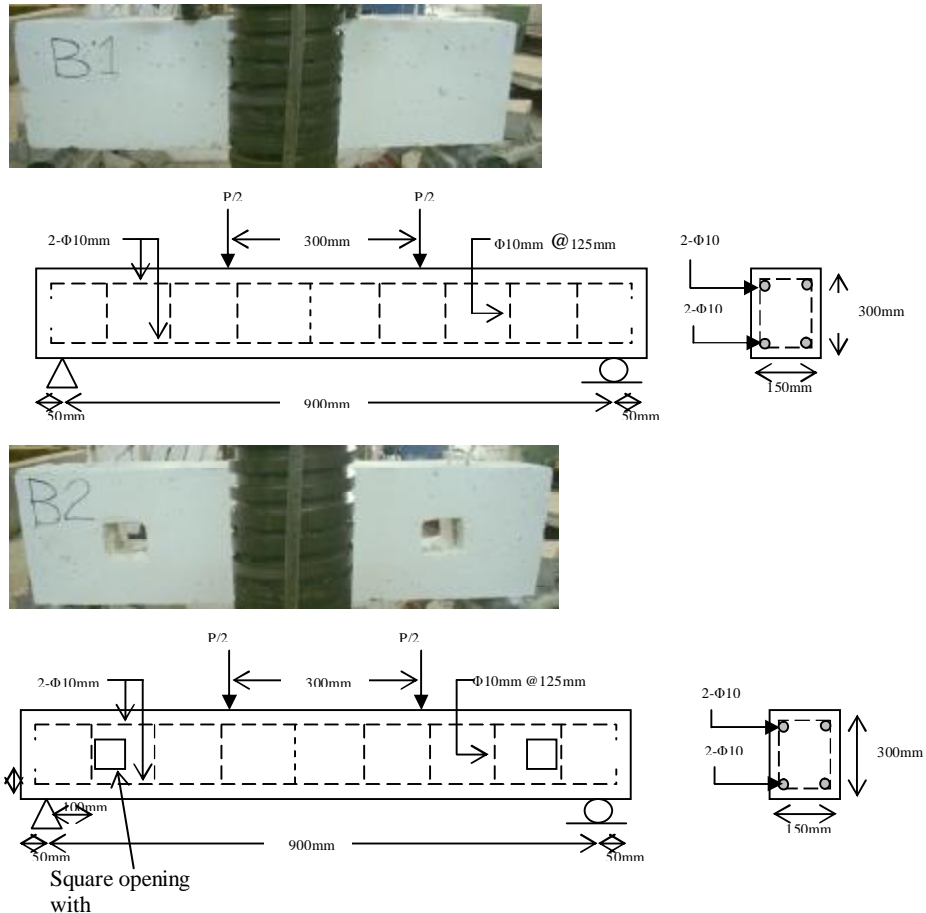
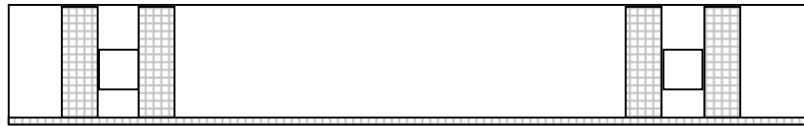

Figure (1) Beams details .

Strengthening

The beam specimens were identified as B3 depending on the strengthening provisions for the opening. Beam Specimen B2 was not strengthened representing a control specimen for the strengthened beams. In Beam B3, the opening was externally strengthened with individual U-wrap CFRP strips having uni-directional fibers. The U-wrap was extended by 100-mm. In addition, the bottom web of the beam were strengthened with CFRP as shown in Fig.(2). The concrete surface beneath the CFRP fabrics, in general, was roughened and then leveled prior to the adhesion using an epoxy.



a) Front view of the strengthened RC beam showing *CFRP*

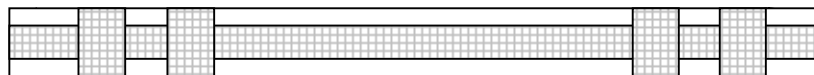

b) Bottom View of the strengthened RC beam showing *CFRP*.

Figure (2) Strengthening of RC beam with pening

Materials

The Ordinary Portland Cement (OPC) was used in casting the beams and the maximum size of coarse aggregate was 20 mm. The concrete mix was designed for 28.5MPa strength. The mix proportion adopted is as shown in Table (1). The compressive strengths of the concrete were obtained from three cubes after 28 days curing according to ASTM.

Table (1): Mix design

Contents (kg/m ³)				
Water – Cement Ratio	Water	Cement	Fine aggregate	Coarse aggregate
0.53	200	378	734	1045

Two 10 mm diameter of high yield deformed bars were used as the tensile reinforcement and used for stirrups. The measured yield and ultimate tensile strength of these bars were 517 MPa, 620 MPa respectively. Table (2) shows the material properties of CFRP laminates were used.

Table (2): Summary of material properties for CFRP

FRP composite	Elastic modulus (MPa)	Major Poisson's ratio	Tensile strength (MPa)	Shear modulus (MPa)	Thickness laminate (mm)
CFRP	E _x =62000 E _y =4800* E _z =4800*	V _{xy} =0.22 V _{xz} =0.22 V _{yz} =0.30*	958	G _{xy} =3270* G _{xz} =3270* G _{yz} =3270**	1.178

*(Kachlakev 2000)

$$** G_{yz} = \frac{E_{y,z}}{2(1 + \nu_{yz})}$$

Figure (3) shows the location of the dial gauge used to record data during testing, was used to measure the vertical deflection of the beam at mid-span and under the two load points. The load was applied incrementally under a load control procedures up to failure.



Figure (3) the dial gauge used to record data during testing.

FINITE ELEMENT MODELLING ((FEM)

Reinforced Concrete

An eight-node solid element, Solid65, was used to model the concrete. The solid element has eight nodes with three degrees of freedom at each node – translations in the nodal x, y, and z directions. The element is capable of plastic deformation, cracking in three orthogonal directions, and crushing. The geometry and node locations for this element type are shown in Fig.(4) [ANSYS, Inc 2007].

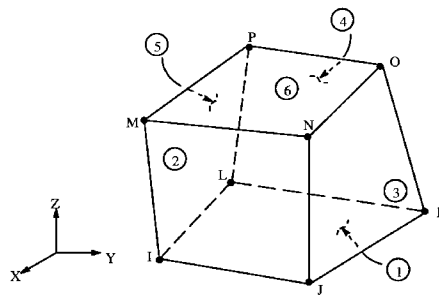

Figure (4) Solid65 – 3-D reinforced concrete solid.

A Link8 element was used to model the steel reinforcement. Two nodes are required for this element. Each node has three degrees of freedom, – translations in the nodal x, y, and z directions. The element is also capable of plastic deformation. The geometry and node locations for this element type are shown in Fig.(5) [ANSYS, Inc 2007].

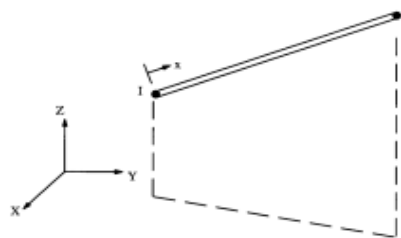

Figure (5) Link8 – 3-D spar.

FRP Composites

A layered solid element, Solid46, was used to model the FRP composites. The element allows for up to 100 different material layers with different orientations and orthotropic material properties in each layer. The element has three degrees of freedom at each node and translations in the nodal x, y, and z directions. The geometry, node locations, and the coordinate system are shown in Fig.(6) [ANSYS, Inc 2007].

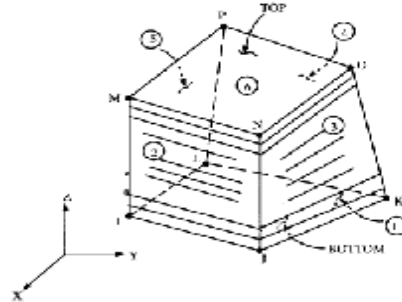

Figure (6): Solid46 – 3-D layered structural

Steel Plates

An eight-node solid element, Solid45, was used for the steel plates at the supports in the beam models. The element is defined with eight nodes having three degrees of freedom at each node – translations in the nodal x, y, and z directions. The geometry and node locations for this element type are shown in Fig.(7) [ANSYS, Inc 2007].

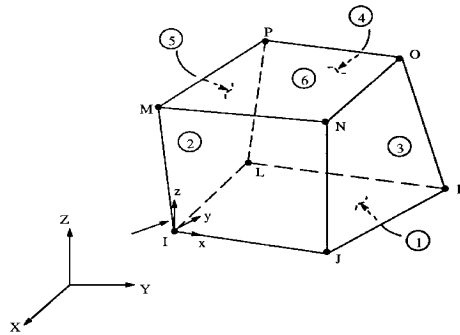

Figure (7): Solid45 – 3-D solid

Due to symmetry half of the beam is modeling as shown in Figure(8).

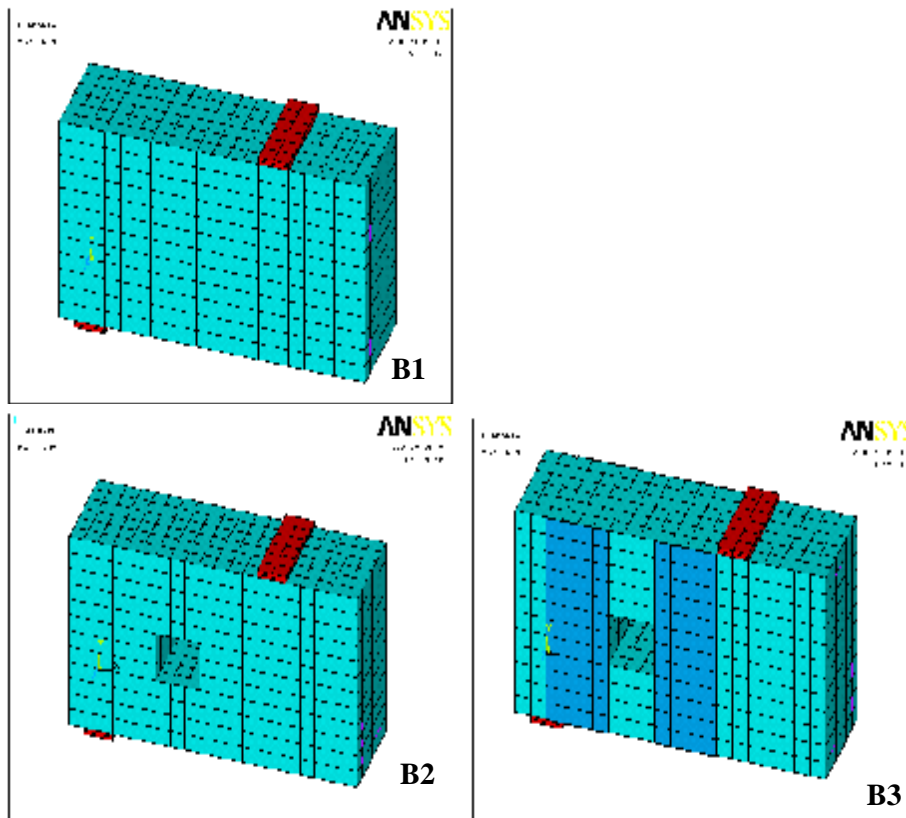

Figure (8): Modeling of the reinforced concrete beams by ANSYS.

RESULTS AND DISCUSSIONS

The validation of the FE models was conducted by comparing the load deflection response of the experimental and the FE models for the three specimens simulated, herein. A comparison between the experimental and FE load-deflection response is presented in Figure (A) comparison between the predicted load capacity, the deflection at failure and the associated results obtained from experimental testing is shown in table (3).

Table (3): Experimental and ANSYS results

Specimen	Failure Load (kN)		Percentage Difference	Maximum Deflection (mm)		Percentage Difference
	Exp.	Ansys		Exp.	Ansys	
B1	170	159.1	6.4%	2.6	2.76	5.8%
B2	142.5	123.56	13.3%	1.95	1.67	14.35%
B3	165	140.54	14.8%	5	3.7	26%

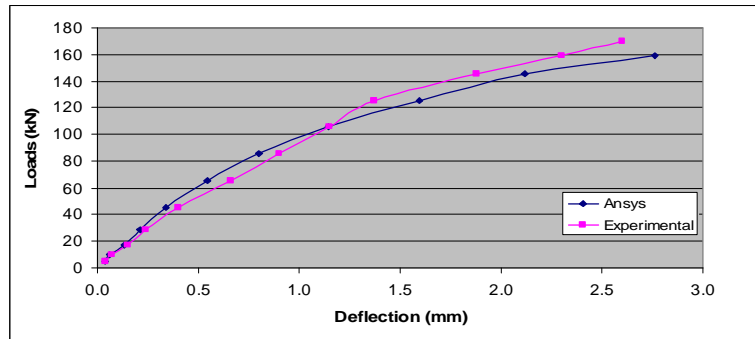

(a) Load-Deflection Curves for Solid Beam (B1)

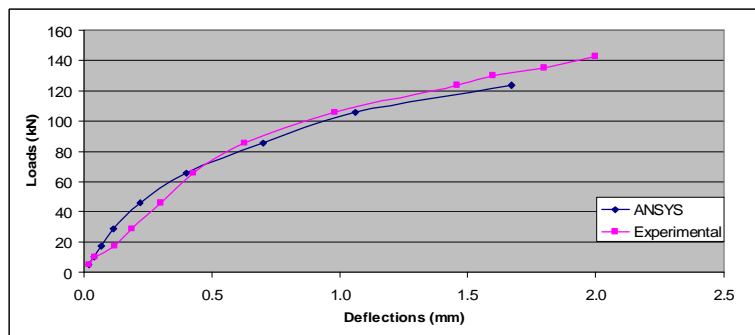

(b) Load-Deflection Curves for Beam with opening (B2)

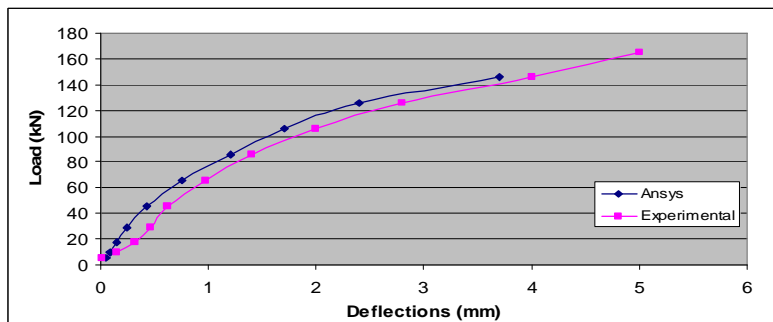

(c) Load-Deflection Curves for Beam with opening and Strengthening by CFRP (B3)

Figure (9): Comparison Between Experimental and FE Models

It is clear from Fig. 9 that there is a good matching between the experimental and FE load-deflection response at all stages of loading till failure. This indicates the validity of the proposed FE models and reliability of FE simulation. Furthermore, Table 3 draws a detailed comparison between the predicted failure load and mid-span deflection. Upon comparison of the failure load, it is evident that FE models predicted the failure load with 6.4% range difference. In the "B1" case, the FE simulation seems to underestimate the failure load for the other cases by 13.3%, 14.8% for the "B2", and "B3" models, respectively. In the same manner, the case of "B1" overestimated the maximum deflection at failure by 5.8% while the rest of the FE models underestimated the maximum deflection at failure by 14.35% and 26% for the "B2" and "B3" models, respectively.

It is clear that whenever the opening is exist, the capacity of the RC beam decrease. In the same manner, the performance of the strengthened beam achieved higher ultimate loads than these without external CFRP sheets strengthening systems. For instance, about 15.8% increases in the capacity were noticed on the "B3" case over this unstrengthened counterpart, "B2".

Figure (10) shows that the crack pattern observed experimentally in specimens B1, B2 and B3, and predicted by the model FE at failure. The ANSYS program records a crack pattern at each applied load step. Fig.10 shows evolutions of crack patterns developing for each beam at the last loading step. ANSYS program displays circles at locations of cracking or crushing in concrete elements. Cracking is shown with a circle outline in the plane of the crack, and crushing is shown with an octahedron outline. The first crack at an integration point is shown with a red circle outline, the second crack with a green outline, and the third crack with a blue outline. [ANSYS, Inc 2007] It is clear that there is a good matching between the observed and predicted crack patterns which prove the capability of the FE model to accurately predict the crack pattern.

In addition to structural strength, ductility is considered to be a major safety consideration in the design of strengthened RC beams. In general, the ductility is characterized by excessive deflection or rotation of structural element while sustaining all its load carrying capacity. A ductile behavior is preferable than the brittle one because it implies the ability of a structure to sustain large deformation without failure. The ductility factor is the ratio of the mid-span deflection at the working ultimate load level. The mid-span deflection of the strengthened specimen "B3" was about 2.5 times of that of the control specimen "B2" at its ultimate load.

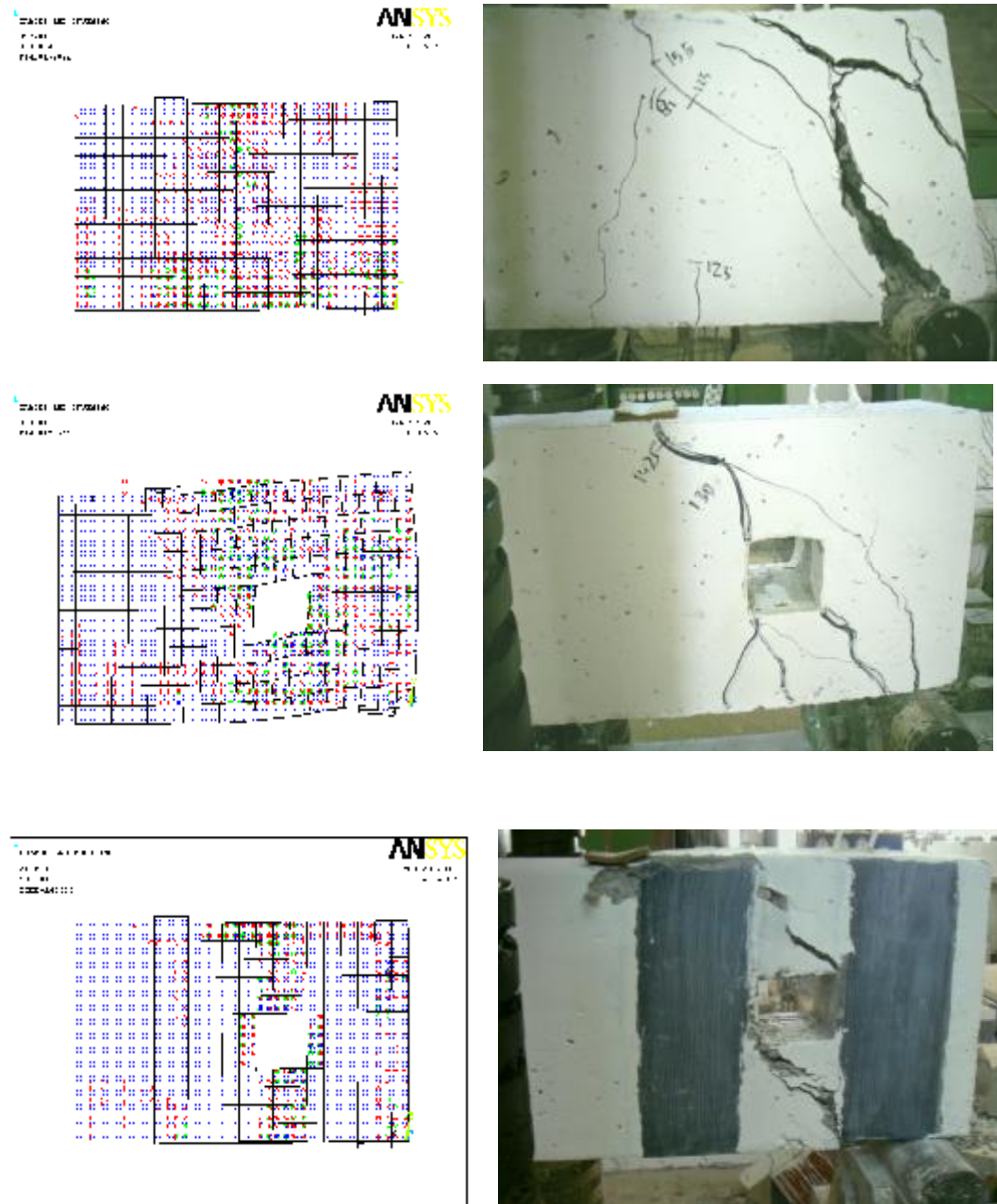

Figure (10): Cracks and Crushing at Ultimate load.

SUMMARY AND CONCLUSIONS

The following conclusions can be stated based on the evaluation of the analyses of the calibration model and the RC beams with square openings:

1. the performance of the strengthened beam achieved higher ultimate load than these without external CFRP sheets strengthening systems.
2. the presence of openings in the RC beams reduces the ultimate load and maximum deflection in the midspan.
3. The strengthened beam gives more ductility than of the un-strengthened beam at its ultimate load
4. The ultimate load obtained by ANSYS for the RC beam without opening is very close to the ultimate load measured during experimental testing.
5. The load-deflection response of the FE models is in a good agreement with the measured experimental response.
6. The developed FE models verified in this study could be used as an alternative to experimental testing, which is usually more costly and time extensive. The FE modeling of the problem can also serve as a numerical platform for performance prediction of RC beams with openings strengthened in shear with CFRP composites.

REFERENCES

- [1]. Abdalla, H.A., A.M. Torkeya, H.A. Haggagb and A.F. Abu-Amira, 2003. Design against cracking at openings in reinforced concrete beams strengthened with composite sheets. *Composite Structures*, 60: 197-204.
- [2]. ANSYS – Release Version 11. A Finite Element Computer Software and User Manual for Nonlinear
- [3]. Mansur, M.A., Huang, L.M., Tan K.H. and Lee, S.L., 1992. Deflection of reinforced concrete beams with web openings. *ACI Structural Journal*, 89(4): 391-397
- [4]. Mansur, M.A., 1998. Effect of openings on the behaviour and strength of R/C beams in shear. *Cement and concrete composites*, 20: 477-486.
- [5]. Hawileh R. A., El-Maaddawy T. A., and Naser M. Z., 2011. Non-linear FE Analysis of RC Deep Beams with openings Strengthened with CFRP Composites. First Middle East conference SMAR 2011
- [6]. Somes, N.F. and Corley, W.G., 1974. Circular openings in webs of continuous beams. American Concrete Institute. Detroit, MI, pp: 359-398.
- [7]. Soroush Amiri, Reza Masoudnia, 2011. Investigation of the Opening Effects on the Behavior of Concrete Beams Without Additional Reinforcement in Opening Region Using Fem Method. *Australian Journal of Basic and Applied Sciences*.
- [8]. Thompson, J.M. and Stephen Pessiki, 2006. Experimental investigation of precast, prestressed inverted-tee girders with large web openings. *PCI Journal*.
- [9]. Kachlakav, D.I. and McCurry, D., Simulated Full Scale Testing of Reinforced Concrete Beams Strengthened with FRP Composites: Experimental Results and Design Model Verification, Oregon Department of transportation, Salem, June2000.