

Design of Active Loop Antenna for Multi-band Radio Reception.

Jabbar S. Hussein
Karbala University

Abstract:

A simple design method of multiband active loop antenna for multiband reception is presented, the propose antenna work for LW and MW. Theoretical overview of the loop antenna is provided where the magnetic field equation is derived. Description of the design consideration and circuit of the antenna are presented, these antenna is simple, cheap and easy to construct and installation. Finally with practical experiment this antenna show good reception properties.

الخلاصة:

تصميم سهل لهوائي حلقي متعدد الحزم (multiband active antenna) هو موضوع بحثنا، الهوائي المقترح يعمل للموجات الطويلة والمتوسطة. تم اشتقاق معادلة المجال المغنطيسي للهوائي. تم وصف او ادراج المواصفات لدائرة الهوائي وكذلك الدوائر الالكترونية للهوائي. هذا الهوائي بسيط ورخيص وسهل التركيب وال نصب، تم اجراء تجارب عملية لاستقبال الاذاعات ضمن عمل الهوائي حيث وجد ان الهوائي يعمل بصورة جيدة.

1-Introduction:

Loop antennas are of interest to a wide range of users, from shortwave listeners (SWLs) and radio amateurs to designers of direction-finding receiver systems. SWLs and radio amateurs living in confined areas such as apartments or in communities having antenna restrictions find loop antennas and especially active loop antennas to be a practical solution as they can offer directional performance similar to that of a dipole antenna while taking up a considerably smaller space, and their small size makes them readily adaptable to mechanical rotation.

However, the high inductive reactance of the loop antenna impedance is detrimental to wideband performance, and remote tuning is often employed for achieving good performance and enjoying the highly desirable magnetic field response, which provides some degree of immunity from electric field noise from sources such as lightning discharges, faulty mains transformers, and fluorescent lighting.

Simple, inexpensive and very versatile antenna type is the loop antenna. Loop antenna takes many different forms such as a rectangle, square, triangle, ellipse, circle and other configurations. Because of the simplicity in analysis and construction, the circular loop is the most popular and has received the widest attention. When it used in any application, it is usually in the received mode, such as portable radio and pagers.

A compact Active magnetic loop antenna primarily designed to provide improved performance over conventional passive and active antennas. This Active loop set standards for the listener. With Active Loop antenna, it is possible to reject locally radiated and mains borne noise and still provide improved sensitivity compared to larger antennas.

2-Broadband Loop Features

With Active Loop antenna, very low inter-modulation products ensures good performance in a strong signal environment, where some active antennas generate inter-modulation products which can appear as spurious signals interfering with reception. This interference or second order inter-modulation is caused by non-linearity in the amplifier, producing signals which are the usually the sum and difference of strong Broadcast stations.

The Broadband Loop has been specifically designed to reduce inter-modulation products to a minimum. The second order and the third order intercept points are typically +70dBm and +40dBm respectively. Thus the level of the inter-modulation products are generally below the atmospheric and manmade noise, so the design has much lower MW Inter-mod.

Up to 30dB rejection of locally radiated and power-line noise compared to an active whip antenna, figure of eight directivity and deep nulls to further reduce interference.

3-Loop Antenna Advantages

The active antenna solves the problem of impedance matching to the feeder and yet the performance is comparable with larger antennas. However, most active antennas are the whip type and respond mainly to the electric-field. The Broadband Loop responds primarily to the magnetic-field as shown in Fig.(1), this ensures high rejection of nearby electric-fields. The intensity of the electric-field is usually higher than the magnetic-field when an antenna is close to interference sources such as TVs florescent lamps, mains wiring etc. Therefore, by rejecting the electric-field there will be a reduction in local interference compared to other types of active and passive antennas. Interference reduction is further enhanced by the deep nulls of the 'Figure-of-Eight' directivity pattern.

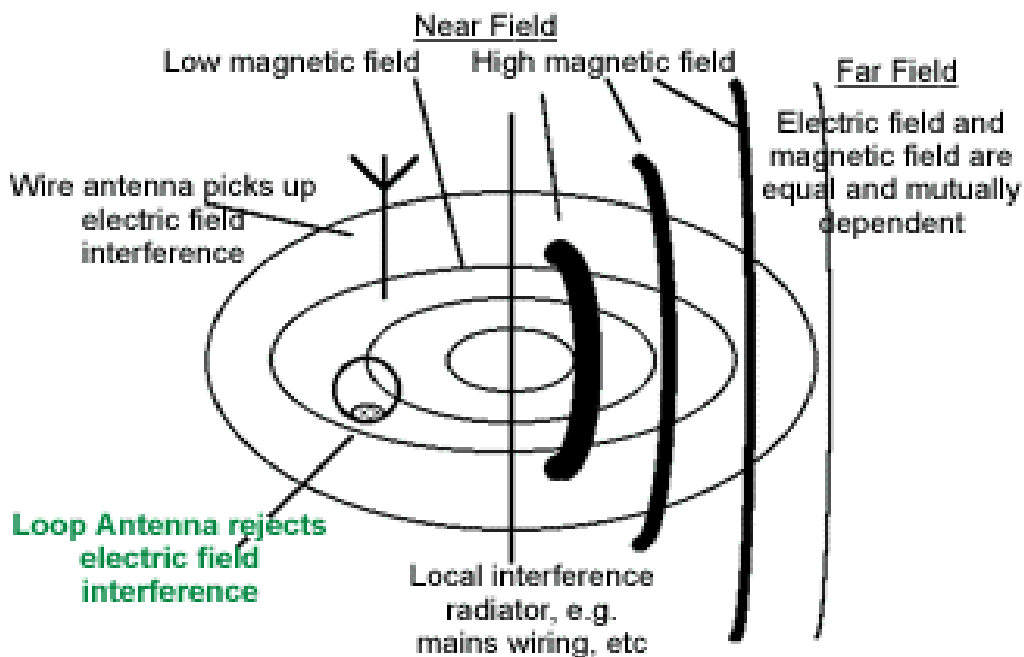

Fig.(1) Conceptual Illustration Of The High *Electric Field* Compared To The *Magnetic Field* Close To A Local Interference Radiator

4-Theory Of Magnetic Loops

Magnetic field intensity, H, expressed in units of amperes per meter, produces a magnetic flux density, B, expressed in volt seconds per square meter. Flux is proportional to applied field.

$$(1) \quad B = \mu H$$

μ , expressed in Henrys per meter, is the magnetic permeability of the medium, the analog of electric permittivity. We will let μ equal μ_0 , the permeability of a vacuum (spacetime itself). This

assumption is well justified for air core loops surrounded by non magnetic media, including air, water, dirt, vegetation, etc.

The total magnetic flux, Φ , in volt-seconds, threading an area is the flux density integrated over the area. The vector \mathbf{n} denotes a unit vector normal to da , the element of the surface being integrated over.

$$(2) \quad \Phi = \int \mathbf{B} \cdot \mathbf{n} \, da$$

Voltage around a loop is proportional to the rate of change of the amount of flux threading the loop area. When multiple turns are in series, the total voltage is the sum of the individual turns.

$$(3) \quad V = N \, d\Phi/dt$$

Notice from (3) that a motionless loop in a constant dc field produces no voltage. Combining these three equations gives an expression for the terminal voltage of a multiturn wire loop. The vector normal component of the H field is integrated over the loop area, and differentiated by time.

$$(4) \quad V = \mu_0 N \, d/dt \int \mathbf{H} \cdot \mathbf{n} \, da$$

When the H field is uniform over a planar loop, we can take H out of the integral and express its vector normal component as the magnitude times the cosine of the angle between the H vector and the loop axis.

$$(5) \quad V = \mu_0 N \cos\theta \, d/dt |\mathbf{H}| \int da$$

and the integral becomes simply the loop area.

$$(6) \quad V = \mu_0 N A \cos\theta \, d/dt |\mathbf{H}|$$

Most of the calculus is solved, but the time derivative of H remains. We can reduce it to simple algebra by examining a discrete frequency (ωt) component of H, with peak amplitude H_0 .

$$(7) \quad \mathbf{H} = H_0 \sin(\omega t)$$

Which transforms equation (6) into:

$$(8) \quad V = \mu_0 N A \cos\theta \, d/dt (H_0 \sin(\omega t))$$

So we now rid ourselves entirely of calculus:

$$(9) \quad V = \mu_0 N A \cos\theta \, H_0 \omega \cos(\omega t)$$

Taking the magnitude of the signal, we get loop terminal voltage as a straight algebraic product of six terms;

$$(10) \quad V = 2\pi\mu_0 N A H_0 f \cos\theta$$

Where:

- $2\pi\mu_0$ is a constant.
- N is the number of turns
- A is the loop area, in square meters.
- H_0 is the applied magnetic field, in amperes per meter.
- f is the frequency, in Hertz.
- $\cos\theta$ is the cosine of the angle between the loop axis and the field.

The persistent product of N and A are the only remaining terms which describe characteristics of the loop itself. This product suggests a figure of merit for loop antennas, the "effective aperture", A_e , which is the physical area times the number of turns.

We can now express the on-axis sensitivity of a loop, which is the terminal voltage divided by the applied magnetic field, as the product of only three terms:

$$(11) \quad V/H_0 = 2\pi\mu_0 f A_e$$

Where:

V/H_0	is the output voltage per unit magnetic field strength applied
$2\pi\mu_0$	is a constant = 7.89×10^{-6} .
A_e	is the loop effective aperture, in square meters.
f	is the frequency, in Hertz.

5-Design considerations

Receiving antennas can be characterized by their “effective height” h_{eff} . The output voltage U for an electrical field strength E is then given by

$$U = h_{eff} \cdot E$$

The effective height of a loop antenna is

$$h_{eff} = 2\pi n A \cos \Phi / \lambda$$

where n is the number of turns, A is the loop area, λ is the wavelength, and Φ is the angle between loop plane and transmitter. As we see, the loop’s output voltage is inverse proportional to λ , or proportional to the frequency f .

Actually the loop senses the magnetic field, not the electrical field. But in the far field of a transmitting antenna (a condition that is usually met), electric and magnetic field vector are simply related by a factor. This is the reason why the output voltage can be expressed in terms of the electrical field strength E .

At 30 kHz, the effective height of a single turn loop of 1 m diameter is only 0.5 mm. This is very small compared to an E-field antenna of similar size: The theoretical value for a 1 m vertical rod over a conducting surface is $h_{eff} = 0.5$ m. So why not increase the number of turns to, say, 1000? Unfortunately the more turns, the larger the inductance L and hence the larger the inductive reactance $X = 2\pi fL$ in series with the “generator” voltage U . In multi-turn loops, L increases by a factor of about $n^{1.8}$. Furthermore, the inductance and the loop’s stray capacitance form a resonant circuit, which may limit the usable frequency range.

On the other hand, if the loop is connected to an amplifier with a very low input impedance, the inductance can be used to compensate for the $U \sim f$ property. If the amplifier’s input resistance is less than the inductive reactance at the lowest frequency of interest, the output voltage is independent of frequency. The low resistance also damps the stray parallel resonance to $Q \ll 1$. Due to the (almost) shortened loop inductance, this kind of antenna is completely insensitive to the E-field.

The loop shown in figure 2 has an inductance of 1.2 mH; its resonance frequency is about 350 kHz. At 10 kHz, the reactance is 75 ohms. With an amplifier input resistance between 30 and 100 ohms, however, the sensitivity was found to be insufficient for frequencies above 70 kHz, compared to my other active antennas, a Rohde & Schwarz HE-011, and a Wellbrook ALA1530 loop. For this reason, a slightly different design was chosen: Instead of using a “zero input impedance” amplifier, the loop is terminated by a load of a few kohms.



Figure 2. The prototype loop has 40 turns and a diameter of 38 cm

5-1:Circuit description

The amplifier circuit shown in figure 3. With the load resistance $R1 = 2.2 \text{ kW}$, the Q factor of the loop's inherent parallel resonance still fairly below 1, hence the resonance does not cause problems. The feedback circuit of R5, R6 and C3 makes the signal loss at low frequencies less severe. Since the antenna was intended for radio monitoring rather than for precise measurements, no further effort was taken to obtain a flat frequency response. Resistor R7 in series with the amplifier output ensures stability when using a long cable.

The circuit is powered remotely through the antenna cable. The splitter made of L1 and C7 can be used, but other power supplies for active antennas might do as well. 24 V supply for the active loop antenna was used. A clean supply voltage is mandatory. Switching regulators (e.g. tapping the PC power supply) will usually cause problems, but linear power supplies can also be noisy. Integrated regulators like the LM317 or the 78xx series need a large capacitor of 1000 μF or more at the input terminal to reduce the noise in the LF and VLF range, in parallel to the common 100 nF.

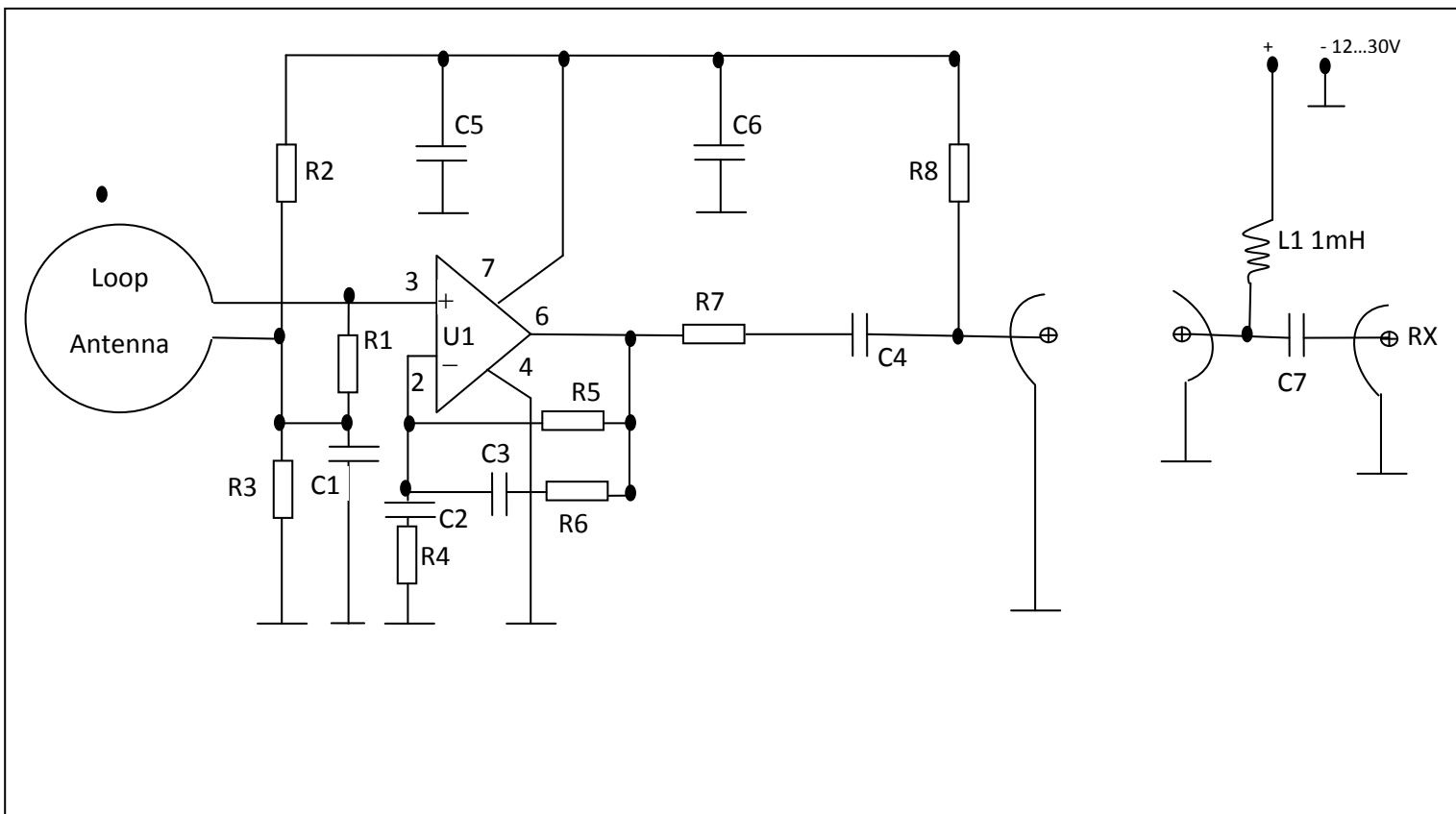

Figure 3. Circuit diagram of the loop amplifier

Table(1) shows the loop amplifier circuit components

Component name	Component value	Component name	Component Value	Component name	Component value
R1	2KΩ	R8	330Ω	C7	1μF
R2	47KΩ	C1	10μF	U1	OP27
R3	47KΩ	C2	47μF		
R4	100Ω	C3	1Nf		
R5	22KΩ	C4	2μF		
R6	1KΩ	C5	100nF		
R7	47KΩ	C6	100μF		

5-2:Construction

As can be seen from figure (2), the construction can be kept very simple. The loop has a diameter of about 40 cm and 40 turns, which needed a little less than 50 metres of wire. Neither the diameter, nor the number of turns nor the exact shape are critical. The loop is easier to wind on some kind of bobbin, a box for example. You can bend the antenna into a circular shape afterwards. A 1.5 mm² “electrician’s wire” (diameter including insulation 2.7 mm, core diameter 1.4 mm) was used. Thinner wire is ok; with a 0.5 mm wire, the inductance will increase by less than 20 percent and the resistance still does not matter. With thick wire, however, the antenna can be built without a supporting structure; the loop in fig. 2 is held together simply by cable binders. The amplifier was

built in a conventional technique (with old-fashioned components that still have wires...) on a small piece of strip-line material (figure 4). An OP27 was chosen for U1 “because it was available in the market”. Other types like LT1028, or so-called audio op-amps like LM833 (a dual op-amp) will probably also work. Anyhow, everything said here should be taken as ideas for own experiments rather than as a bullet-proof recipe; the whole thing can still be optimized.

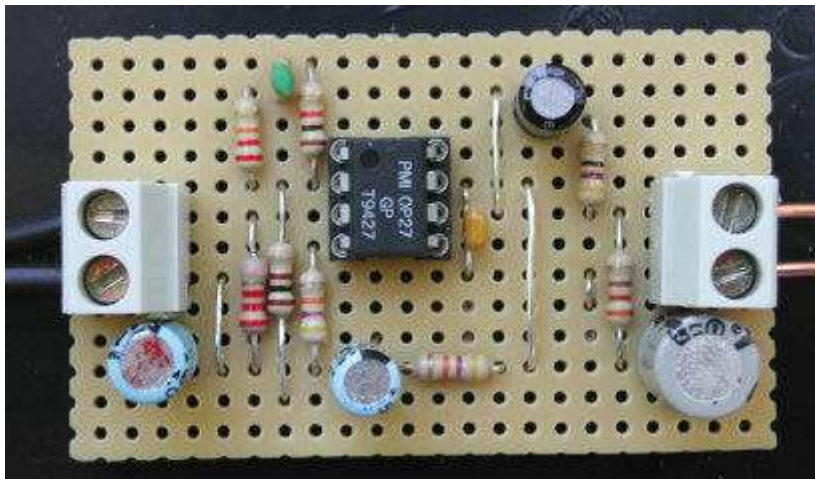

Figure 4. The amplifier circuit

5-3:Practical experiences

The results with this antenna of course strongly depend on the local noise floor. While writing this, I can hear BBC(12.88kHz) and SAWA station (15.50KHz), with the loop two arm lengths away from the computer. Below about 250 kHz, the antenna has very sharp bearing minima. You can at least distinguish whether a station is located in direction NW or in NNW (or in the opposite directions of course, as bearings with loops are ambiguous). A precise direction calibration down to the one degree level is pointless, not only due to the semi-rigid construction, but also due to the portable character of the antenna, since the deviation strongly depends on the environment.

As a consequence of the non-zero termination resistance, the loop is a bit sensitive to electrical field components and to capacitive coupling at higher frequencies, and above 250 kHz, the antenna slightly “squints”. That is, bearing is still possible, but the angle between the two minima is not exactly 180°, and the antenna should be rotated without grasping the loop itself. Below about 100 kHz, however, the loop is completely insensitive to touching.

6-Conclusions:

- 1-loop antenna is used for reception batter than transmission,
 - 2- Active antenna has improve performance
 - 3-No planning problems, work at ground level,
 - 4-has low noise performance
 - 5-Low inter-modulation distortion,
 - 6-Easy to construct and installation, cheap and simple
- Ideal for LW/MW with antenna rotator
 - No tuning necessary or matching unit

7- References:

- 1- Sensitivity of Multi Turn Receiving Loops by William E. Payne, N4YWK, July 2001
- 2- Active Loop Antenna ALA1530 for long wave, medium wave and short wave radio reception -Wellbrook Communications
- 3- active receiving antennas -electronics projects kits
- 4- Antenna and wave propagation by: A.K. GAUTAM-2003
- 5- Antenna Handbook by Balanis-1988
- 6- Sensitivity of Multi Turn Receiving Loops by William E. Payne, N4YWK
- 7- Loop antenna design and Construction, Magnetic Loop Antenna <http://www.educyclopedia.be/>
- 8- Constantine A. Balance "Antenna Theory", Harper & Row publishing Inc. 1982.
- 9- Henry Jasik, "Antenna Engineering Handbook", by Mcgraw-Hill, Inc., 1961.
- 10- Klaus Betke, "A small LF loop antenna", July 2001
- 10- Marco Bruno, IK0ODO: *Thinking about Ideal Loops*. February 2001. Available at
- 11- Trond Jacobsen: *The Russian VLF Navaid System Alpha, RSDN-20*. July 2000. Available at www.vlf.it.