



Available online at: [www.basra-science\\_journal.org](http://www.basra-science_journal.org)



ISSN -1817 -2695

## Using a single switch Working with soft Switching topology for the design and a study of an AC –AC Converter

Hassanin A. Hanon \* and Sawsan S.F Al-ghazawi\*\*

\*Computer Center, \*\* College of Education

Basra University/Iraq

E-mail:hassanin71@Gmail.com

Received 29-3-2011,Accepted 26-9-2011

### Abstract

In this study, a proposed AC - AC Converter has been implemented by using a single switch conductor in parallel with electronic circuit. The proposed converter Consists of LRC output filter and also input circuit consists of a bridge rectifier and RC filter. The circuit have one controlled power switch operates in soft switching mode and serves as a high frequency generator. Output power is controlled via switching frequency. This Circuit can be used in industrial thermal applications. A detailed analysis of the models has been investigated in this paper.

**Keywords:** LCR-filter, AC-AC Converter, Soft Switching, Industrial thermal applications.

### 1. Introduction

The common circuit of an AC-AC converter for thermal applications, in general includes a frequency controlled current source or a voltage source inverter and a controlled rectifier. It is a famous fact that the input rectifier does not ensure a sine wave input current, and is characterized by a low power factor [1,2,3]. Recently many studies of high power factor rectifiers with a single switch have been made [4,5]. These studies are also characterized by a close to sine wave input current. In addition ,the study of the AC-AC converter for induction heating is described[6]. The input circuit of the converter is constructed similarly to the input circuit, which also ensures a high power factor. However the inverting circuit is constructed by traditional mode with four controlled switches. The above literature does not deal with closed loop modeling and embedded

the implementation of AC to AC converter fed induction heater. In the present work AC to AC converter is modeled and it is implemented using a Soft switching controller. The present problem aims to minimize the cost of induction heater system by using an embedded controller[7].

In the proposed scheme show in figure(1) there are two main advantages:

- It is characterized by a high power factor and a sine wave input current.
- On the other hand the inverter circuit is constructed with a single controlled switch, which serves as a high-frequency generator for induction heating[8-9].

Static frequency converters have been extensively applied in industry as a medium or high frequency power supply for the induction heating and melting installations. They are applied in all branches of the

military, machine-building industries, jewellery, smithy heating, domestic heating

cooking devices and other purposes[10].

### 2. Operation Fundamental

The complete schematic of proposed topology is shown in figure(1); The theoretical waveforms are shown in figure(2). In this case the switching frequency is much higher

than the input line frequency and the analysis arbitrarily chose the time interval where  $v_{in} > 0$ .

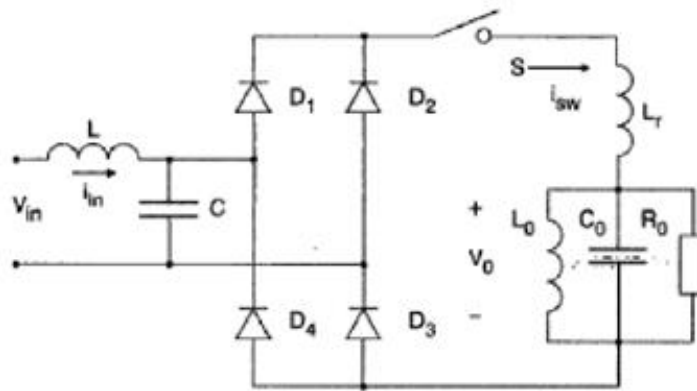

Figure(1) The proposed AC-AC Converter Diagram

#### 2.1. period 1: $t_0-t_1$

The equivalent circuit is shown in figure(3). The switch "S" and four diodes "D1-D4" are turned-off. In this time the capacitor "C" charges up practically linearly at a rate and a polarity corresponding to the instantaneous input voltage " $v_{in}$ ".

#### 2.2 . period 2: $t_1-t_2$

This Interval is shown in figure(4). The switch "S" and " $D_1, D_2$ " are turned-on. At this time the capacitor "C" is discharges via the circuit " $C-D_1-S-L_r$ -load- $D_3$ ". The

capacitor voltage reduces to zero at the end of the period.

#### 2.3. period 3: $t_2-t_3$

All the diode and switch "S" turned-on when this period started, as shown in figure(5). The current through switch "S" flows via two parallel bridge branches. At the end of this interval, the switch current decreases to zero, at this moment the switch turns-off and the process starts from the beginning.

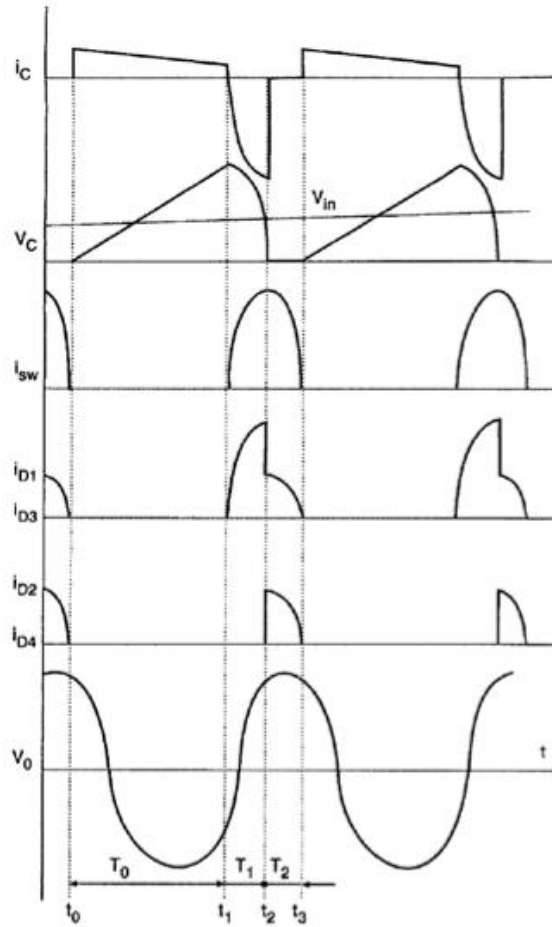

Figure(2). The theoretical waveforms of the proposed convert

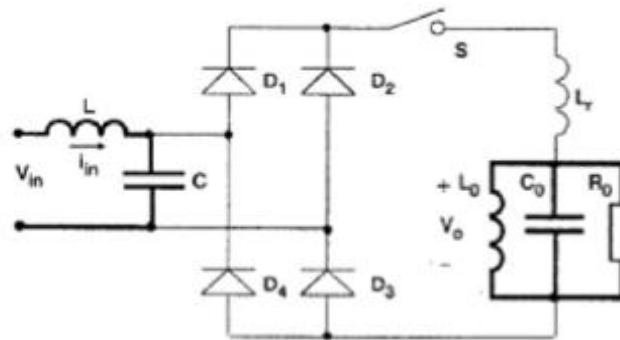

Figure(3).The AC-AC Converter: period 1

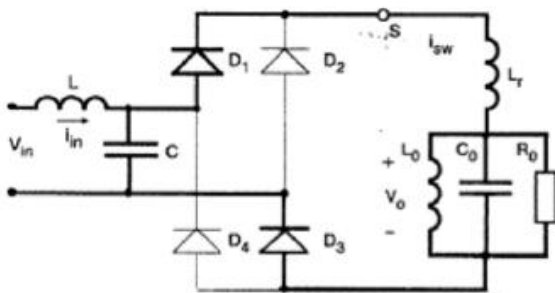

Figure (4) .The AC-AC Converter: period 2

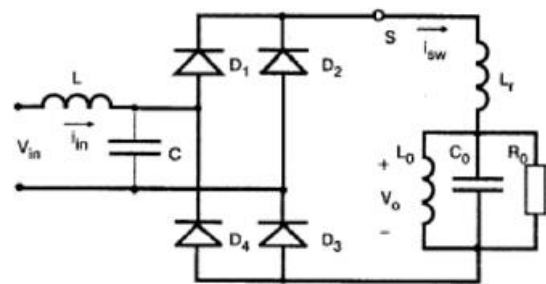

Figure (5) .The AC-AC Converter: period

### 3. Analysis of Operation

The principle circuit operation analysis is based on the usually accepted assumption that all circuit components are ideal. The approximate analytical calculations are based on two additional assumptions:

- The load power is determined by the first harmonic of the load voltage.

- The switch current can be approximated by a semi sinusoidal waveform.

In this converter optimal range of normalized parameters was chosen. The maximum normalized value of switch voltage is:

$$(v_{swmax}^* = v_{swmax} / v_B = 4 - 5).$$

To present these values, it is necessary to choose the following ranges of the normalized circuit parameters:

$$L_1^* = \frac{L_r}{L_o} = 0.1 - 0.2; \omega_r^* = \frac{1}{\omega_s \sqrt{L_r C}} = 3 - 5; \omega_s^* = 1.1 - 1.9 \quad (1)$$

Note: means that the value is normalize.

Where  $(L_r, L_o)$  and  $L_{r1}^*$  are output inductances and normalize inductance and  $\omega_r, \omega_s$  and  $\omega_s^*$  are resonance frequency,

switch frequency and normalize frequency, respectively. The evaluation of the relationship between input and output voltages  $M_g = V_o/V_{in}$

$$A_1 = \frac{I_{sw,max}}{i_{in}} = \frac{\pi(1 - D + D_1)}{D(1 - \cos(\pi \frac{D_1}{D}))} \quad (2)$$

$$A_2 = \frac{I_{sw1,max}}{I_{sw,max}} = \frac{2D}{\pi(1 - 4D^2)} \cdot \cos(2\pi D) \quad (3)$$

$$A_3 = \frac{I_{R1,max}}{I_{sw1,max}} = \frac{1}{\sqrt{1 + R_o^2(\omega_s^* - 1/\omega_s^*)^2}} \cdot \cos(2\pi D) \quad (4)$$

$$M_g = \frac{V_{o,r.m.s}}{V_{in,r.m.s}} = \frac{\sqrt{2}}{A_1 \cdot A_2 \cdot A_3} = \sqrt{2} \cdot \frac{\sqrt{1 + R_o^2(\omega_s^* - \frac{1}{\omega_s^*})^2} (1 - \cos(\frac{\pi \cdot D_1}{D}))}{1 - \pi(1 - D - D_1)} \quad (5)$$

This relationship is represented in figure(6). The values of duty cycles  $D_1$  and  $D$  may be calculated from figure(7). The values of duty cycles  $D_1$  and  $D$  may also be found

$$D_1 \approx (325.8 - 36.7\omega_r^* - 33.4\omega_s^* - 25.4R_o^* + 2.2\omega_r^*R_o^* + 7.4R_o^*\omega_s^*)10^{-3}$$

$$D \approx (-88.3 - 445.5L_r^* - 15.5\omega_s^* + 175.1\omega_s^* + 19.3R_o^* + 725L_r^*\omega_s^* - 10.3R_o^*\omega_s^*)10^{-3}$$

from the approximate polynomial expressions:

$$\left. \begin{array}{l} (6) \end{array} \right\}$$

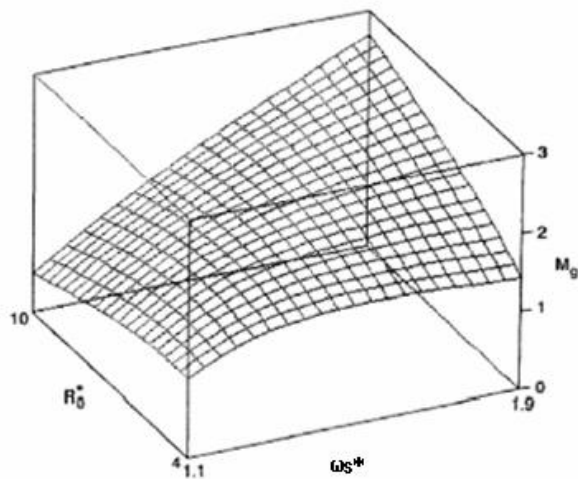

Figure(6). Duty cycle against parameters  $L_r^*$ ,  $\omega_s^*$  and the gain (M)

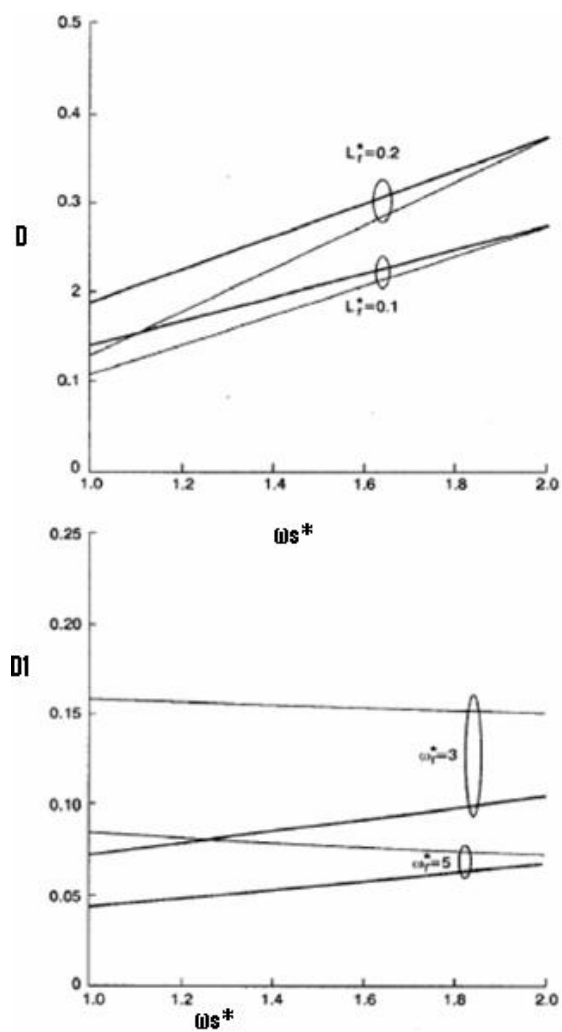

Figure(7). Relationship between the duty cycle  $D, D_1$  and normalize frequency ( $\omega_s^*$ )

#### 4. Simulation Results

The AC-AC converter fed induction thermal is simulated using matlab simulink and their results are presented in this section. The circuit topology of AC-AC converter is shown in figure(8). oscilloscope are connected to measure output voltage, driving pulses and capacitor voltage.

Voltage and current waveforms of the switch are shown in figure(9) , figure(10) respectively. Switching pulses are shown in figure(11). High frequency AC output of converter is shown in figure(12). A disturbance is given at the input by using two switches. Output voltage is sensed and it is compared with the reference voltage.

The error signal is given to the controller. Response of open loop system is shown in figure (13).The output voltage of closed loop system is shown in figure(14). The

disturbance is applied at 3.0 seconds. The control circuit takes proper action to reduce the amplitude to the set value and settles after 0.5 seconds. Thus the closed loop system reduces the steady state error.

Figure(15) shows the relationship between the efficiency and the frequency of the converter, the figure illustrate that the efficiency is high at (1.7-20)KHz.

The output power and frequency relationship is shown in figure(16) where the power is high in high frequency range.

The single-switch AC-AC converter was built and tested at 230V. The circuit parameters are  $R_0=60\Omega$ ;  $L_0=150\mu\text{H}$ ;  $C_0=2.35\mu\text{F}$ ;  $L_r=22\mu\text{H}$ ;  $L_i=8.0\text{mH}$ ;  $C_{in}=0.94\mu\text{F}$  and the switching frequency  $\omega_s=(62-113) \times 10^3 \text{ s}^{-1}$ .

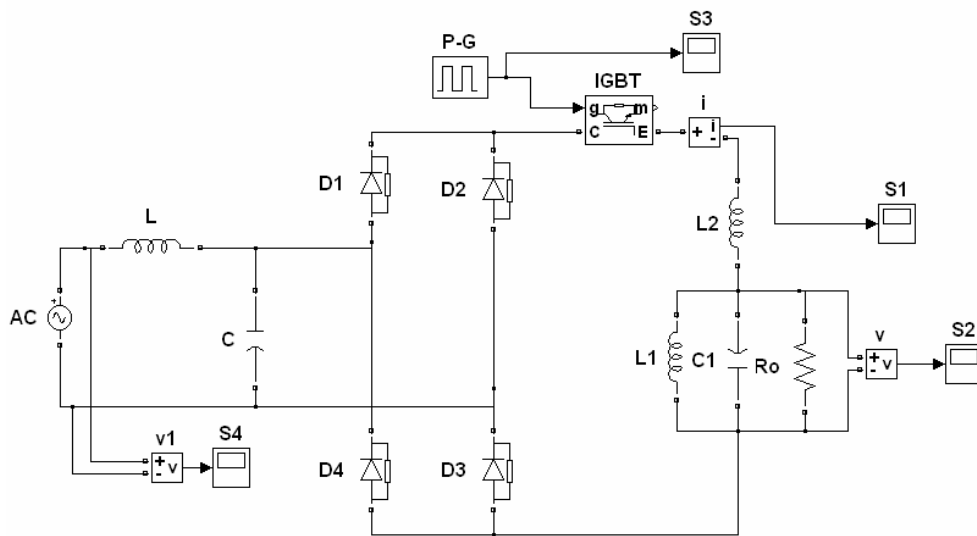

Figure(8).The Proposed AC-AC Converter circuit diagram

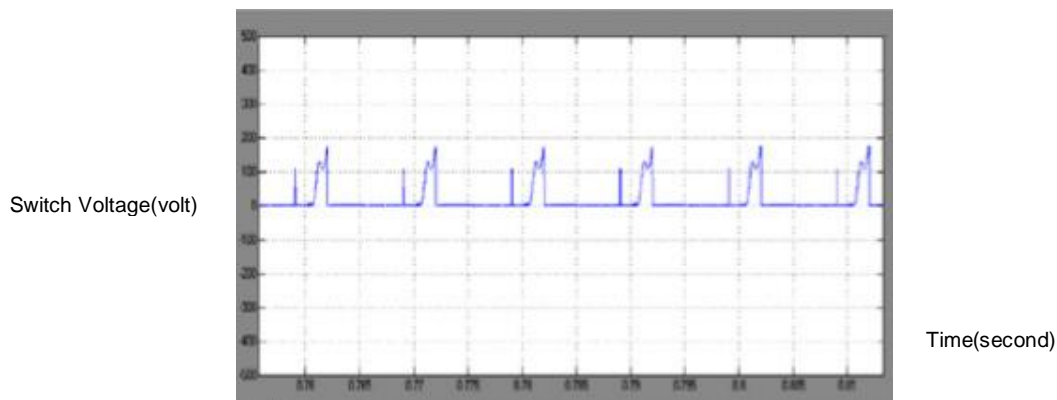

Figure(9). Voltage across  $S_1$  ( $V_{ds}$ ) waveform

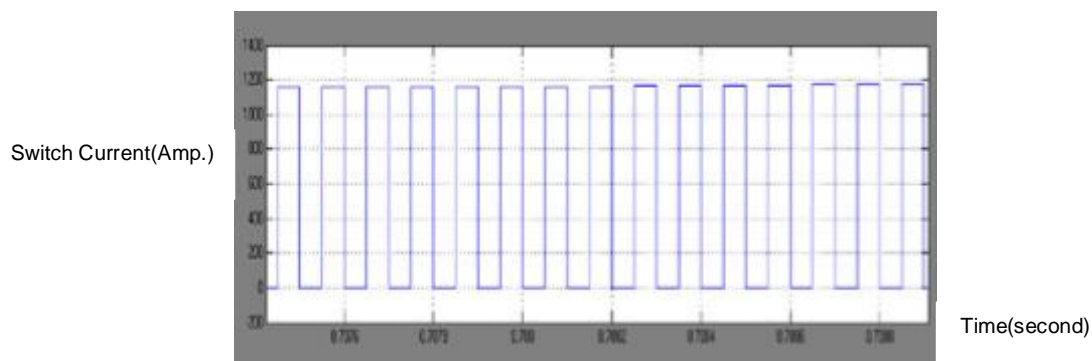

Figure(10). The current through  $S_1$  waveform

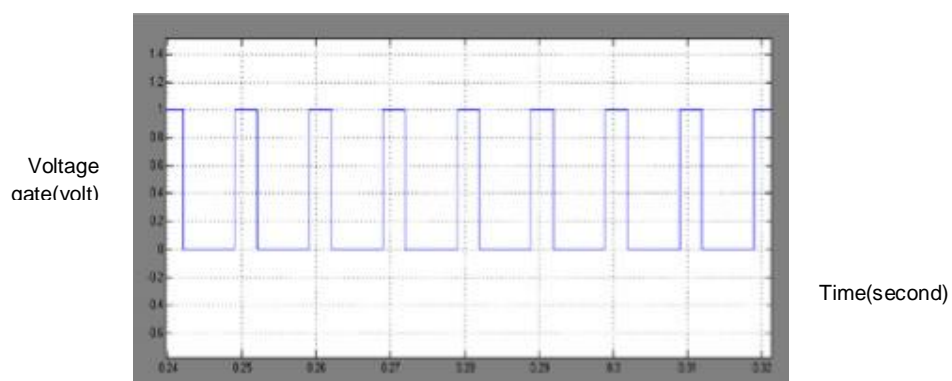

Figure(11). The switch pulses gate

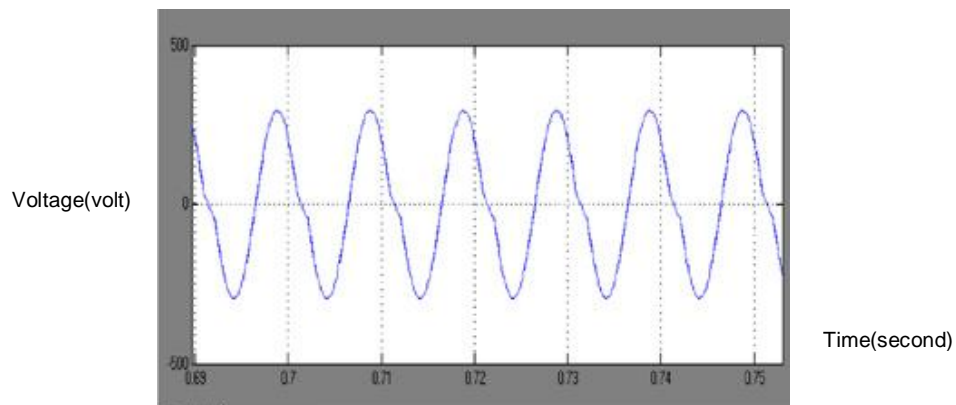

Figure(12). The AC Output Voltage

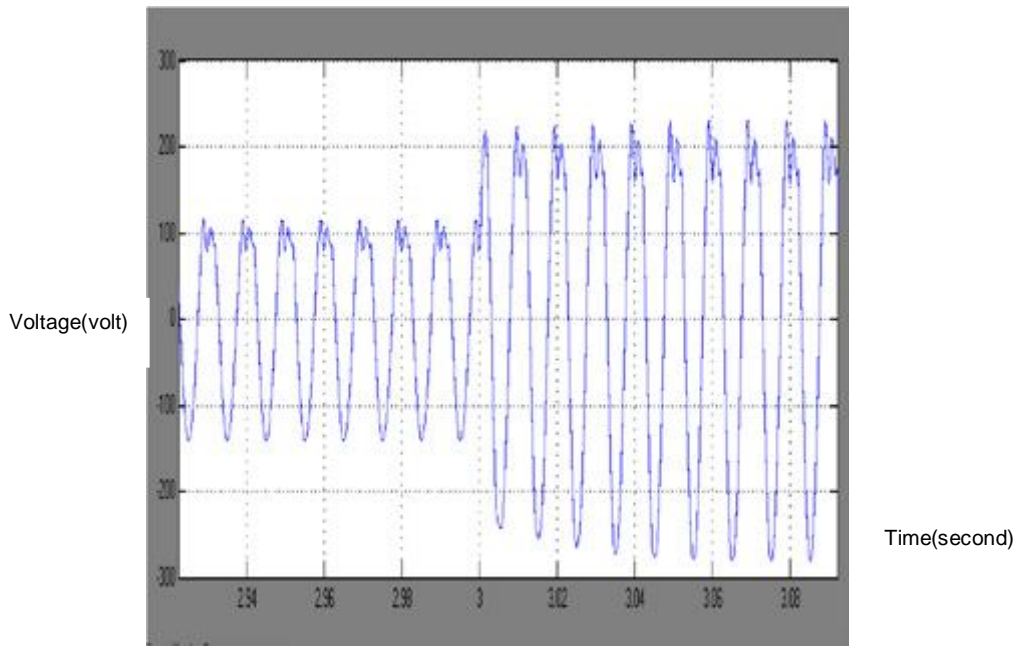
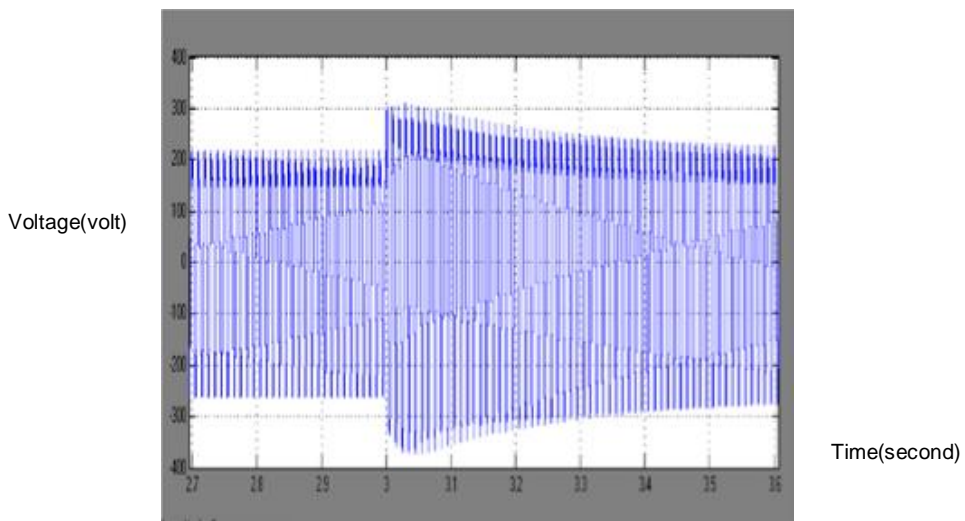
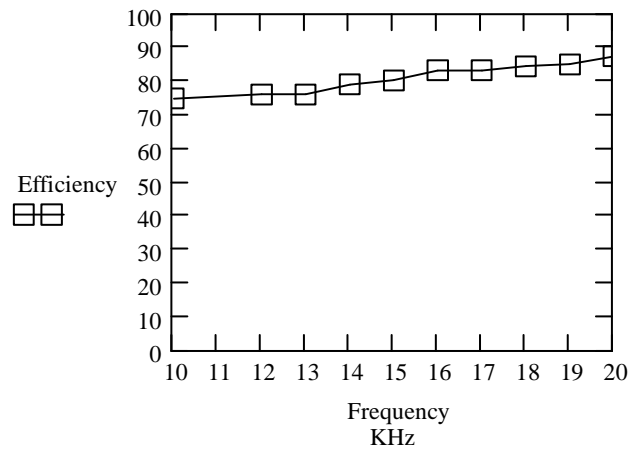

Figure (13). The Output voltage of open loop system



Figure(14). The Output voltage of closed loop system





Figure(15) .The Relationship between the Efficiency and Frequency

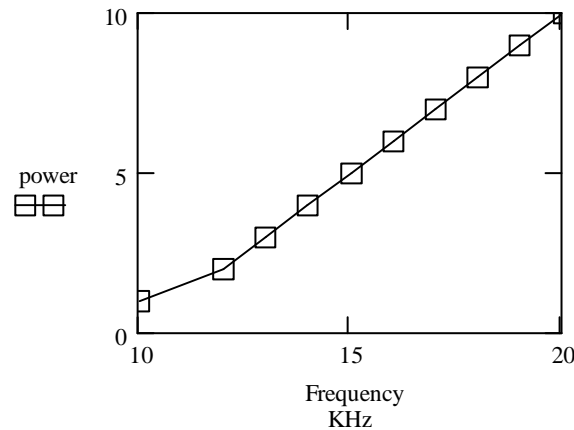

Figure(16). Form shows the relationship between power output and frequency

### 5. Conclusion

A proposed AC-AC Converter has been tested and simulated. The converter input current is practically sinusoidal and its power factor is close to unity. The circuit topology is very simple since includes only one power switch and also low-cost. This switch operates in a soft switching mode. The converter provides a wide-range power control. This converter has many advantages such as reducing the hardware

element, reducing stresses, high power density and high efficiency. Closed loop circuit model is developed and it is successfully used for simulation studies. The limitations of this converter are the presence of DC component in the output current and operating frequency is limited to 11kHz. Waveform and Simulation results demonstrate the actual converter capability to control the heat.

### References

- 1- I. Buchmann, "Batteries in a Portable World: A Handbook on Rechargeable Batteries for Non-Engineers", 2nd ed. Richmond (Vancouver), Canada: Cadex Electronics Inc., May 2001.
- 2- N. Mohan, T. M. Undeland, and W. P. Robbins, "Power Electronics: Converters, Applications, and Design", 3rd ed. New York: John Wiley & Sons, Oct. 2002.
- 3- M. Hankaniemi, M. Karppanen, and T. Suntio, "Dynamical Characterization of Voltage-Mode Controlled Buck Converter Operating in CCM and DCM," in 12th International Power Electronics and Motion Control Conference, pp. 816–821, Aug. 2006
- 4- Y. Ren, M. Xu, J. Zhou, and F. Lee, "Analytical loss model of power MOSFET," IEEE Transactions on Power Electronics, vol. 21, no. 2, pp. 310–319, Mar. 2006.
- 5- B. W. Williams, "Principles and Elements of Power Electronics, Devices, Drivers, Applications, and Passive Components," 2006.
- 6- K.Y. Saha,; S.K. Suh,; Kwon, and M. Nakaoka, "Selective dual duty cycle controlled high frequency inverter using resonant capacitor in parallel with an auxiliary reverse blocking switch," J.Power Electron., vol.7, no.2, pp118–123,(Apr. 2007).
- 7- B.Singh,; B.N.Singh ;, A. handra,; K. Al-Haddad,; A. Pandey, ;D.P. Kothari, "A review of three-phase improved power quality AC-DC converters". IEEE Trans. Ind.

- Electron., Vol. 51, No. 3, pp. 641-660.,(June 2004).
- 8- S.V. ,Mollov, ;M. Theodoridis,; A.J, Forsyth, “High frequency voltage-fed inverter with phase-shift control for induction heating”, IEE Proc.-Electr. Power Appl., Vol. 151, No. 1, pp. 12-18, . (January 2004)
- 9- M. Mohan,; Ned Undeland,;Tore & Robbins, ;P. William,” Power Electronics: Converters, Applications, and Design”. 3. edition. Hoboken: John Wiley & Sons, Inc. Page 25, (2003).
- 10- Ping Chen and K.S. Ashoka Bhat,” Analysis and design of a soft switched AC-DC converter operating in DCM”, HAIT Journal of Science and Engineering B, Volume 2, Issues 3-4, pp. 327-351, (6 June 2005).

## استخدام مفتاح منفرد يعمل بتقنية المفتاح الناعم لتصميم محول تيار متناوب –تيار متناوب ودراسته

\*حسنيين عبدالوهاب حنون و سوسن شريف فايفل الغزاوي\*\*  
\*مركز الحاسبة الالكترونية  
\*\*كلية التربية  
جامعة البصرة/العراق

### المستخلص

في هذه الدراسة سوف يقدم محول تيار متناوب- تيار متناوب والذي أنجز باستخدام مفتاح منفرد مربوط بالتوازي مع الدائره الالكترونيه. يحتوي المحول على مرشح خرج عباره عن محاثه ومقاومه و متسعة وايضا يحتوي على دائرة دخول تحتوي على قنطرة دايمودات ومرشح مقاومة متسعة. تحتوي الدائره مفتاح سيطرة قدره واحد يعمل بنمط المفاتيح الناعمة وبالترددات العاليه. القدرة الخارجيه مسيطر عليها من خلال تردد المفتاح. هذه الدائره تستخدم في التطبيقات الصناعيه الحراريه. تحليل الدائرة مبين بالتفصيل في هذا البحث.