

Simulation of Indirect Field-Oriented Induction Motor Drive System Using Matlab/Simulink Software Package

Raad S. Fayath* Mostafa M.Ibrahim** Majid A. Alwan***
Haroutuon A. Hairik**

*Al-Nahreïn University, College of Engineering

**University of Basrah, College of Engineering, Department of Electrical Engineering

*** University of Basrah, College of Engineering, Department of computer Engineering

Indexing terms: IFO, Induction motor, Matlab/Simulink, AC drives.

Received 14/2/2005, Accepted 17/7/2005

Abstract

This paper presents a methodology for computational modeling of the indirect field-oriented (IFO) induction motor drive system. The numerical model of the squirrel-cage, three-phase induction motor is represented as a system of differential equations. In order to study the performance of the system a simulation program was implemented using Matlab/Simulink software package. The induction motor is supplied by a space vector *Pulse Width Modulation* (PWM) inverter which is implemented also by the same simulation program. The dynamic curves of the motor phase current, voltage, speed and electromagnetic torque during starting and steady-state conditions are plotted. The step change loading effects on the stationary reference frame stator current components, synchronous rotating frame stator current components, electromagnetic torque and stationary reference frame rotor flux components are observed.

1-INTRODUCTION

In field orientation, the motor input currents are adjusted to set a specific angle between fluxes produced in the rotor and stator windings in a manner that follows from the operation of a dc machine. When the dynamic equations for an induction motor is transformed by means of well known rotating transformation methods into a reference frame that concedes with rotor flux, the results become similar to the dynamic behavior of a dc machine. This allows the ac motor stator current to be separated into a flux-producing component and an orthogonal torque-producing component, analogous to a dc machine field current and armature current [1]. The key to field-oriented control is knowledge of the rotor flux position angle with respect to the stator. Applications in which rotor flux is sensed are now generally termed "Direct Field Orientation" (DFO) methods. It is possible to compute the angle from shaft position information, provided that other motor parameters are known. This approach is now generally termed "Indirect Field Orientation" (IFO) [2]. Whatever the field-orientation approach, once the flux angle is known, an algorithm performs the transformation from three-phase stator currents into the orthogonal torque and flux producing components. Control is then performed in these components, and an inverse transformation is used to determine the necessary three-phase currents or voltages[3].

2-MATHEMATICAL DESCRIPTION OF THREE-PHASE INDUCTION MOTOR

The space vector forms of the voltage equation give the induction motor model. The system model defined in the stationary α,β - coordinate system attached to the stator is expressed by the following equations [4]. The motor model is supposed to be ideally symmetrical with a linear magnetic circuit characteristic.

a- *The stator voltage differential equations:* [See Appendix (A)]

$$v_{s\alpha} = R_s i_{s\alpha} + \frac{d}{dt} \lambda_{s\alpha} \quad \dots(1)$$

$$v_{s\beta} = R_s i_{s\beta} + \frac{d}{dt} \lambda_{s\beta} \quad \dots(2)$$

b-The rotor voltage differential equations:

$$v_{r\alpha} = 0 = R_r i_{r\alpha} + \frac{d}{dt} \lambda_{r\alpha} + w \lambda_{r\beta} \quad \dots(3)$$

$$v_{r\beta} = 0 = R_r i_{r\beta} + \frac{d}{dt} \lambda_{r\beta} - w \lambda_{r\alpha} \quad \dots(4)$$

c-The stator and rotor flux linkages expressed in terms of the stator and rotor current space vectors:

$$\lambda_{s\alpha} = L_s i_{s\alpha} + L_m i_{r\alpha} \quad \dots(5)$$

$$\lambda_{s\beta} = L_s i_{s\beta} + L_m i_{r\beta} \quad \dots(6)$$

$$\lambda_{r\alpha} = L_r i_{r\alpha} + L_m i_{s\alpha} \quad \dots(7)$$

$$\lambda_{r\beta} = L_r i_{r\beta} + L_m i_{s\beta} \quad \dots(8)$$

d- Electromagnetic torque expressed by utilizing space vector quantities:

$$T_e = \frac{3}{2} P (\lambda_{s\alpha} i_{s\beta} - \lambda_{s\beta} i_{s\alpha}) \quad \dots(9)$$

Besides the stationary reference frame attached to the stator, motor model voltage space vector equations can be formulated in a general reference frame, which rotates at a general speed (w_a). If a general reference frame, with direct and quadrature axes x,y rotating at a general instantaneous speed $w_a=d\theta_a/dt$ is used, as shown in Fig.(1), where θ_a is the angle between the direct axis of the stationary reference frame (α) attached to the stator and the real axis (x) of the general reference frame, then the following equation defines the stator current space vector in general reference frame [5]:

$$\bar{i}_{sa} = \bar{i}_s e^{-j\theta_a} = i_{sx} + j i_{sy} \quad \dots(10)$$

The stator voltage and flux-linkage space vector can be similarly obtained in the general reference frame. Similar considerations hold for the space vectors of the rotor voltages, currents and flux linkages. The real axis ($r\alpha$) of the reference frame attached to the rotor is displaced from the direct axis of the stator reference frame by the rotor angle θ_r . It can be seen that the angle between the real axis (x) of the general reference frame and the real axis of the reference frame rotating with the rotor ($r\alpha$) is $(\theta_a - \theta_r)$. In the general reference frame, the space vector of the rotor currents can be expressed as:

$$\bar{i}_{ra} = \bar{i}_r e^{-j(\theta_a - \theta_r)} = i_{rx} + j i_{ry} \quad \dots(11)$$

Where \bar{i}_r is the space vector of the rotor current in the rotor reference frame. Similarly the space vectors of the rotor voltages and rotor flux linkages in the general reference frame can be expressed. The reference frames may be aligned with the stator flux-linkage space vector, the rotor flux-linkage space vector or the magnetizing space vector. The most popular reference frame is the reference frame attached to the rotor flux linkage space vector with direct axis (d) and quadrature axis (q). After transformation into d-q coordinates the motor model is the following [6]:

$$v_{sd} = R_s i_{sd} + p \lambda_{sd} - w_s \lambda_{sq} \quad \dots(12)$$

$$v_{sq} = R_s i_{sq} + p\lambda_{sq} - \omega_s \lambda_{sd} \quad \dots(13)$$

$$v_{rd} = 0 = R_r i_{rd} + p\lambda_{rd} - (\omega_s - \omega) \lambda_{rq} \quad \dots(14)$$

$$v_{rq} = 0 = R_r i_{rq} + p\lambda_{rq} + (\omega_s - \omega) \lambda_{rd} \quad \dots(15)$$

$$\lambda_{sd} = L_s i_{sd} + L_m i_{rd} \quad \dots(16)$$

$$\lambda_{sq} = L_s i_{sq} + L_m i_{rq} \quad \dots(17)$$

$$\lambda_{rd} = L_r i_{rd} + L_m i_{sd} \quad \dots(18)$$

$$\lambda_{rq} = L_r i_{rq} + L_m i_{sq} \quad \dots(19)$$

$$T_e = \frac{3}{2} P (\lambda_{sd} i_{sq} - \lambda_{sq} i_{sd}) \quad \dots(20)$$

Fig.(2) represents a Matlab/Simulink model of the three-phase induction motor in the stationary reference frame.

3- FIELD-ORIENTED CONTROL OF THREE PHASE INDUCTION MOTOR [See Appendix (B)]

This control is usually performed in the reference frame (d-q) attached to the rotor flux space vector. That's why the implementation of vector control requires information on the modulus and the space angle (position) of the rotor flux space vector. The stator currents of the induction machine are separated into flux-and torque producing components by utilizing transformation to the d-q coordinate system, whose direct axis (d) is aligned with the rotor flux space vector. It means that the q-axis component of the rotor flux space vector is always zero.

$$\lambda_{rq} = 0 \quad \text{and also} \quad p\lambda_{rq} = 0 \quad \dots(21)$$

Fig.(3) shows the basic structure of the indirect field-oriented control of the three-phase induction motor.

4-ROTOR FLUX MODEL

Knowledge of the rotor flux space vector magnitude and position is key information for the three phase induction motor vector control. With the rotor magnetic flux space vector, the rotational coordinate system (d-q) can be established. There are several methods for obtaining the rotor magnetic flux space vector. The implemented flux model utilizes monitored rotor speed and stator voltages and currents. It is calculated in the stationary reference frame (α - β) attached to the stator. The rotor flux space vector is obtained by solving the following two differential equations, which are resolved into the α and β components [7].

$$[(1 - \sigma)\tau_s + \tau_r] p\lambda_{r\alpha} = \frac{L_m}{R_s} v_{s\alpha} - \lambda_{r\alpha} - \omega \tau_r \lambda_{r\beta} - \sigma L_m \tau_s p i_{s\alpha} \quad \dots(22)$$

$$[(1 - \sigma)\tau_s + \tau_r] p\lambda_{r\beta} = \frac{L_m}{R_s} v_{s\beta} - \lambda_{r\beta} + \omega \tau_r \lambda_{r\alpha} - \sigma L_m \tau_s p i_{s\beta} \quad \dots(23)$$

5-DECOUPLING CIRCUIT

For purposes of the rotor flux-oriented vector control, the direct-axis stator current i_{sd} (rotor flux-producing component) and the quadrature-axis stator current i_{sq} (torque-producing component) must be controlled independently. However, the equations of the stator voltage components are coupled. The direct axis component v_{sd} also depends on i_{sq} and the quadrature axis component v_{sq} also depends on i_{sd} . The stator voltage components v_{sd} and v_{sq} cannot be considered as decoupled control variables for the rotor flux and electromagnetic torque. The stator currents i_{sd} and i_{sq} can only be independently controlled (decoupled control) if the

stator voltage equations are decoupled and the stator current components i_{sd} and i_{sq} are indirectly controlled by controlling the terminal voltages of the induction motor. The equation of the stator voltage components in the d-q coordinate system (12) and (13) can be reformulated and separated into two components, (i) linear components v_{sd}^{lin} , v_{sq}^{lin} (ii) decoupling components $v_{sd}^{decouple}$, $v_{sq}^{decouple}$ [8]. The equations are decoupled as follows:

$$v_{sd} = v_{sd}^{lin} + v_{sd}^{decouple} = [K_R i_{sd} + K_L p i_{sd}] - [w_s K_L i_{sq} + \frac{\lambda_{rd} L_m}{L_r \tau_r}] \quad \dots(24)$$

$$v_{sq} = v_{sq}^{lin} + v_{sq}^{decouple} = [K_R i_{sq} + K_L p i_{sq}] - [w_s K_L i_{sd} + \frac{\lambda_{rd} L_m}{L_r} w] \quad \dots(25)$$

where

$$K_R = R_s + \frac{L_m^2}{L_r} R_r \quad \dots(26)$$

$$K_L = L_s - \frac{L_m^2}{L_r} \quad \dots(27)$$

and the decoupling components are :

$$v_{sd}^{decouple} = -[w_s K_L i_{sq} + \frac{L_m}{L_r} \lambda_{rd}] \quad \dots(28)$$

$$v_{sq}^{decouple} = [w_s K_L i_{sd} + \frac{L_m}{L_r} w \lambda_{rd}] \quad \dots(29)$$

The decoupling algorithm transforms the nonlinear motor model to linear equations which can be controlled by general PI or PID controllers instead of complicated controllers.

6-PROPOSED INDIRECT FIELD-ORIENTED CONTROL SCHEME

Fig.(4) shows the implemented block diagram of an induction motor indirect field-oriented control, incorporating a decoupling circuit. The details of Fig.(4) are represented in Figs.(5,6,7,8 and 9). The starred variables represent the reference values of the variables, and are obtained under constant flux condition.

$$i_{sd}^* = \frac{\lambda_{rd}^*}{L_m} \quad \dots(30)$$

$$i_{sq}^* = \frac{2L_r T_e^*}{P L_m \lambda_{rd}^*} \quad \dots(31)$$

$$w_{sl}^* = \frac{2L_r T_e^*}{P \tau_r \lambda_{rd}^{*2}} \quad \dots(32)$$

$$w_{sl} = w_s - w \quad \dots(33)$$

The rotor speed and flux dynamics are reduced to simple linear systems. PI controllers can then be used to achieve satisfactory regulation. For the speed, the parameters of the PI controller are designed on the basis of the rotor electrical and mechanical time constants.

7-SIMULATION RESULTS

In this section, the simulation results are presented to verify the feasibility of the proposed overall model. Fig. (10) shows the rotor (electrical) speed in which at t=2.5 seconds a full load torque step change is applied. The electromagnetic torque profile of this case is

shown in Fig. (11). Also the direct-quadrature axis rotor flux components in the stationary reference frame are shown in details for this case in Fig. (12), while the direct-quadrature axis stator current components in the stationary reference frame are shown in Fig (13). The stator phase current and voltage are shown in Fig. 14 and 15 respectively, for the full load condition. The effects of the full load torque step change on the synchronous rotating d-q components of the stator current are shown in Figs. 16 and 17 which clarifies the decoupling process of the two-stator current components in a very good illustrated method.

For the same system and for another run it is assumed a steady state full load operation and a step down change in speed is applied at t=3 seconds. The speed and the electromagnetic torque profile for this case of operation are shown in Fig. (18) and (19) respectively, while Fig. (20) and (21) represent respectively the direct and quadrature axis stator currents (in the synchronous rotating frame) characteristics during this step change.

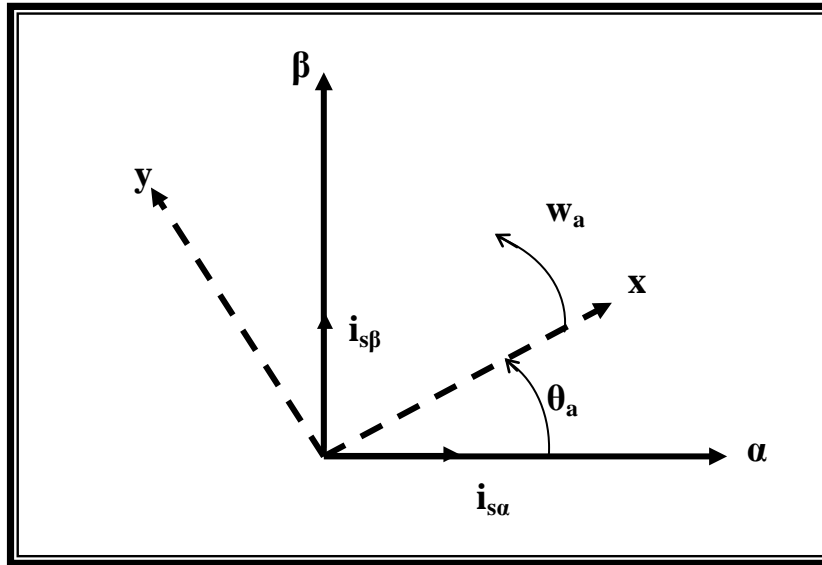

Fig.(1) The general reference frame and the x, y axes rotating at a general speed

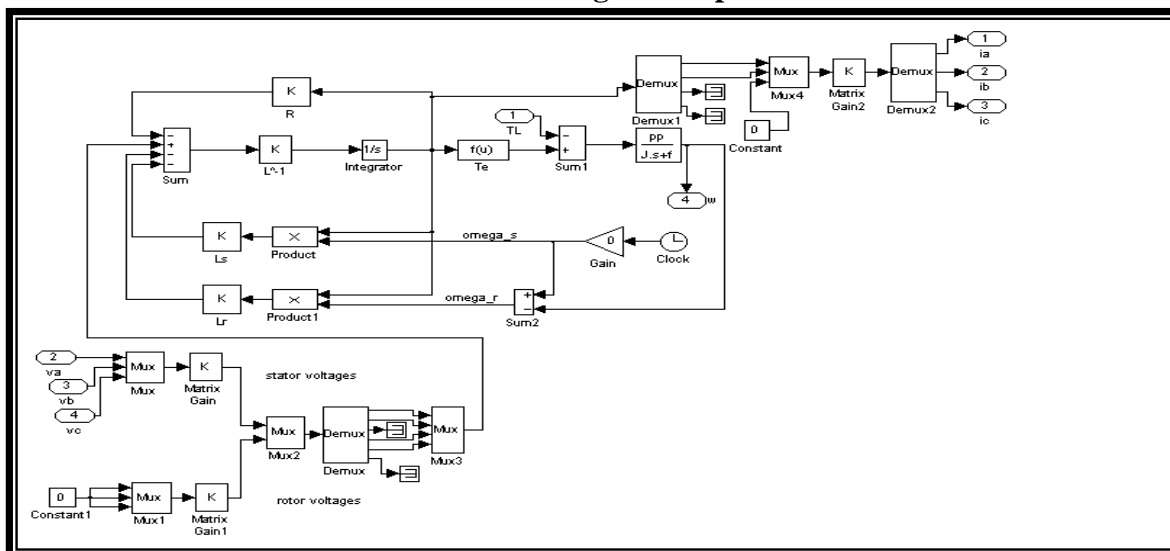

Fig. (2) Matlab/Simulink model of the three-phase induction motor in the stationary reference frame.

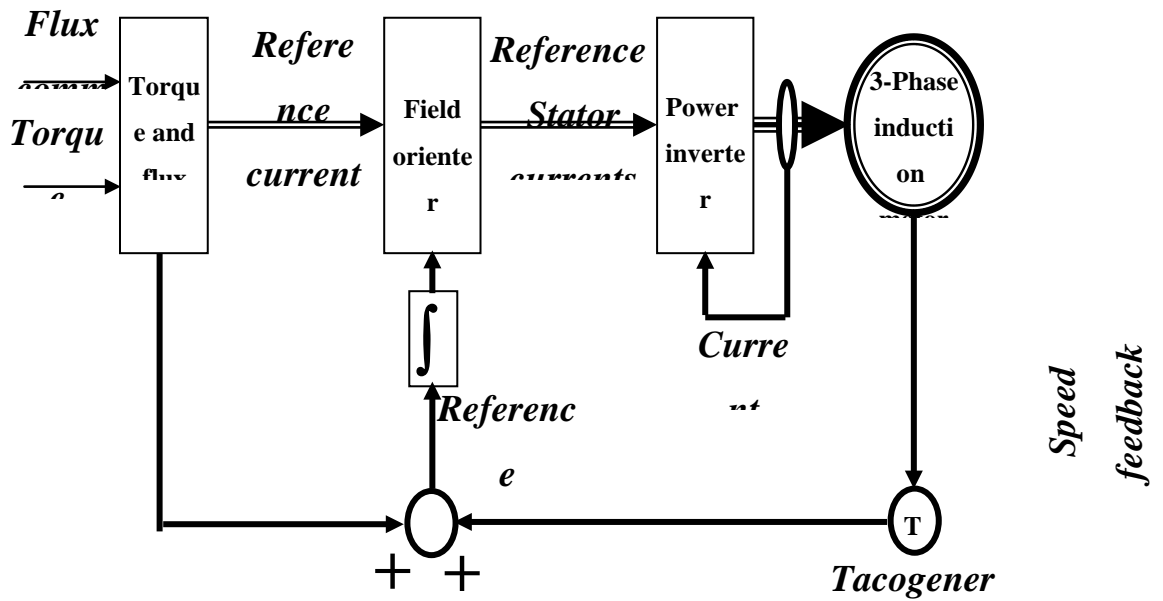

Fig. (3) Block diagram of the indirect field oriented induction motor drive system

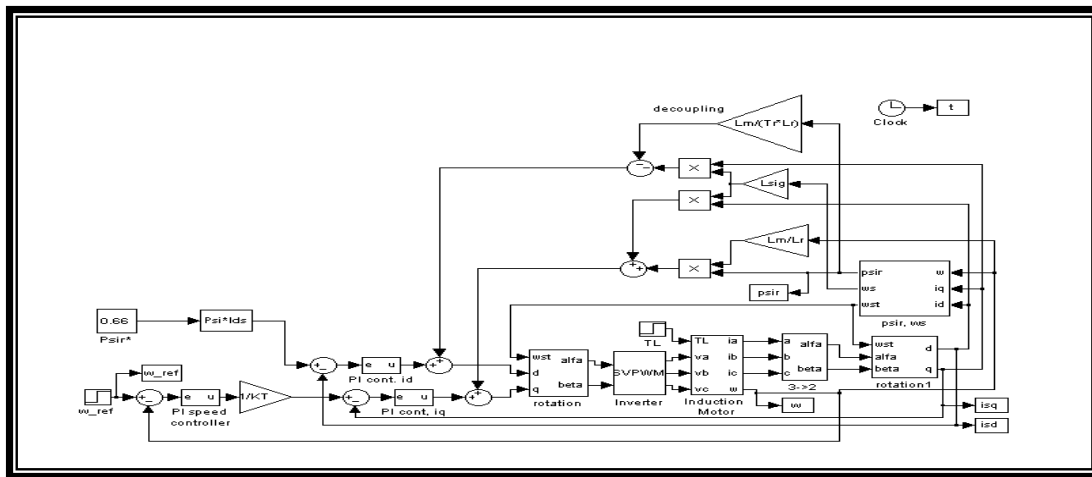

Fig. (4) The Matlab/Simulink model of the indirect field-oriented control of the three phase induction motor.

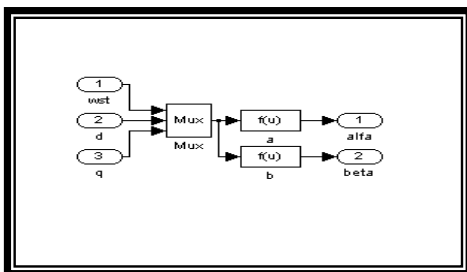

Fig.(5) d-q to alpha-beta transformation

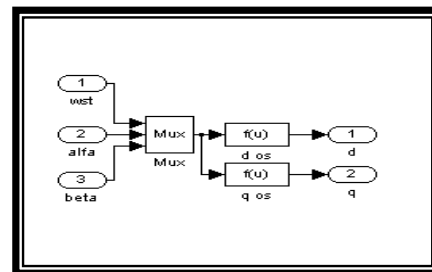

Fig.(6) alpha-beta to d-q transformation

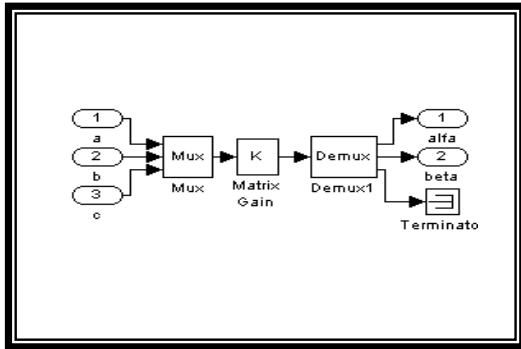

Fig.(7) a,b,c to alpha-beta transformation

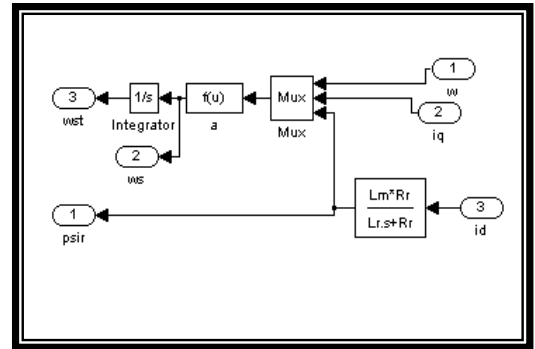

Fig.(8) Rotor flux vector angle calculation block

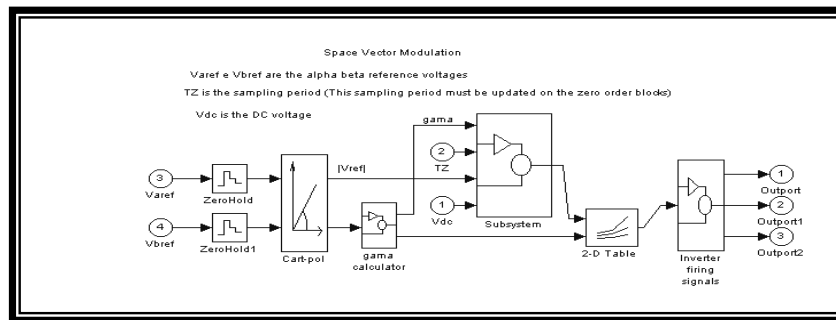

Fig.(9) The space vector PWM Inverter Matlab/Simulink model

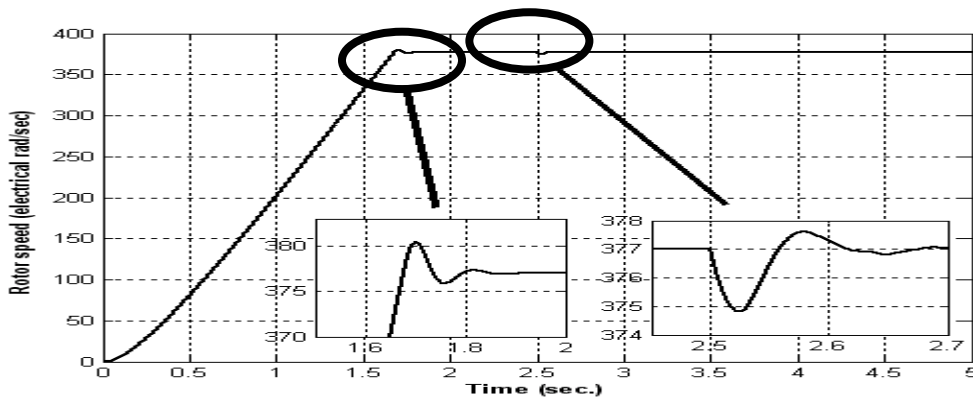

Fig.(10) Rotor electrical speed profile with full-load torque step change at t=2.5 sec.

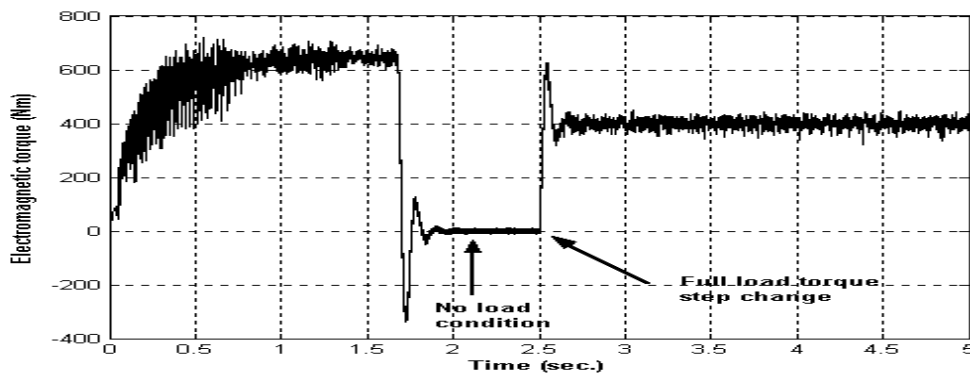

Fig.(11) Electromagnetic torque of the three-phase induction motor with a full-load torque step change at t=2.5 sec.

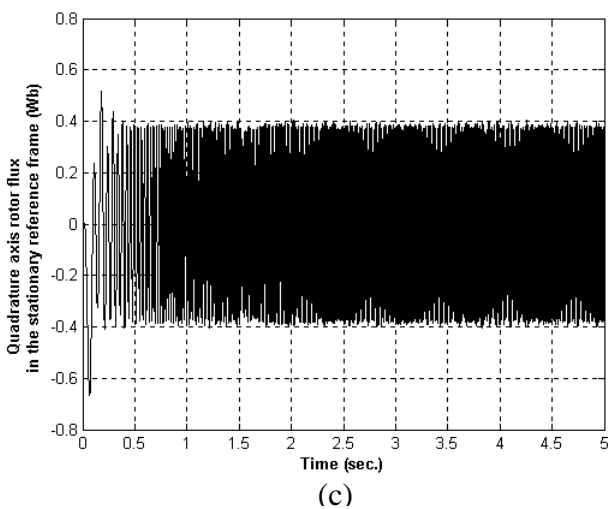
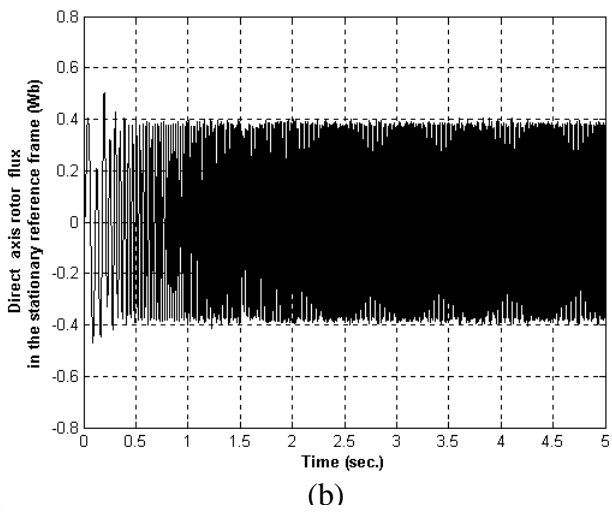
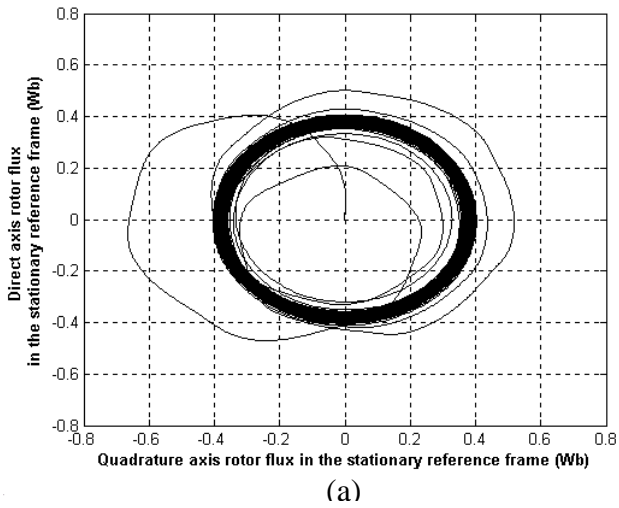

Fig.(12)

- a) Rotor flux space phasor evolution.
- b) Rotor flux beta-component.
- c) Rotor flux alpha-component.

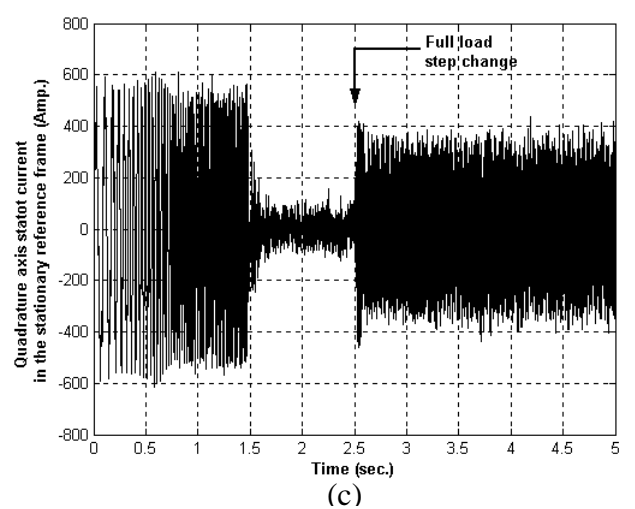
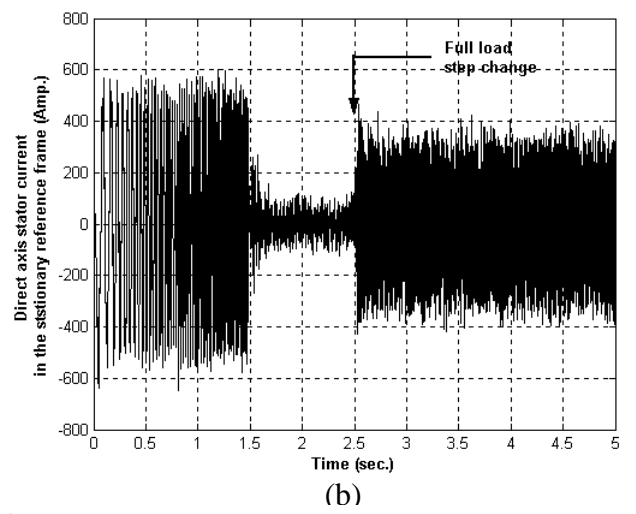
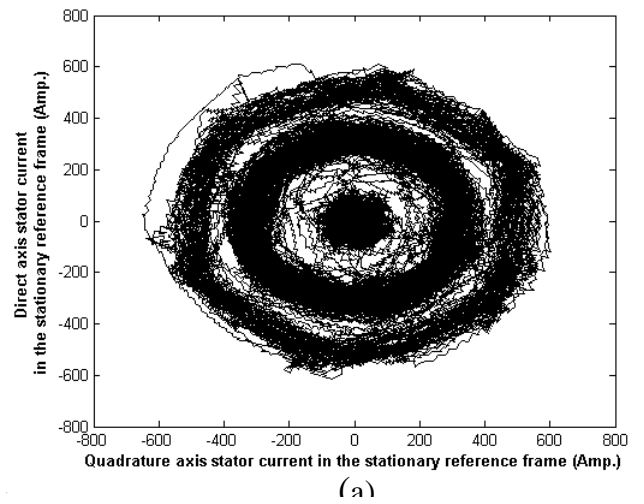

Fig.(13)

- a) Stator current space phasor evolution.
- b) Stator current beta-component.

c) Stator current alpha-component.

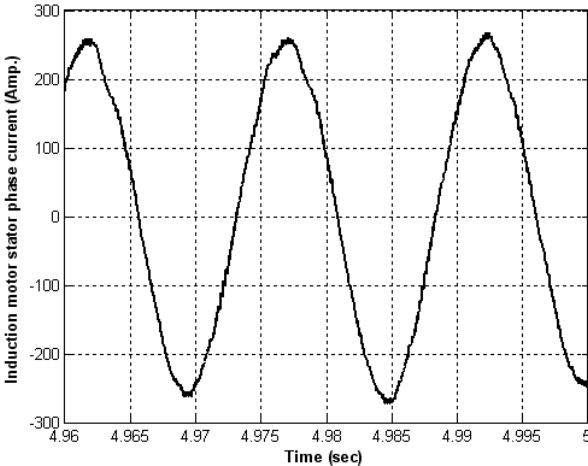

Fig.(14) Stator phase current at full-load.

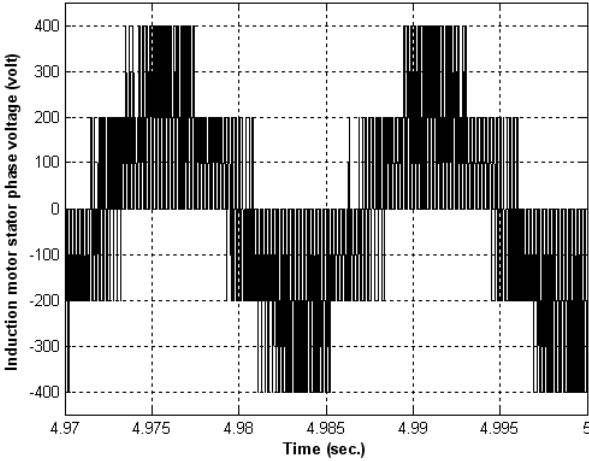

Fig.(15) Stator phase phase voltage at full-load.

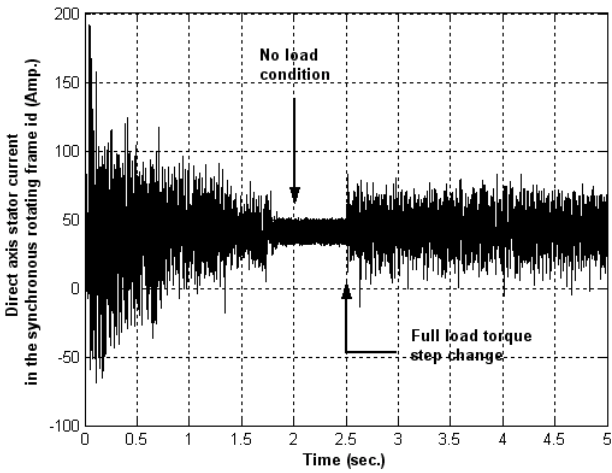

Fig.(16) Stator current d-component for a full-load torque step change at t=2.5 sec.

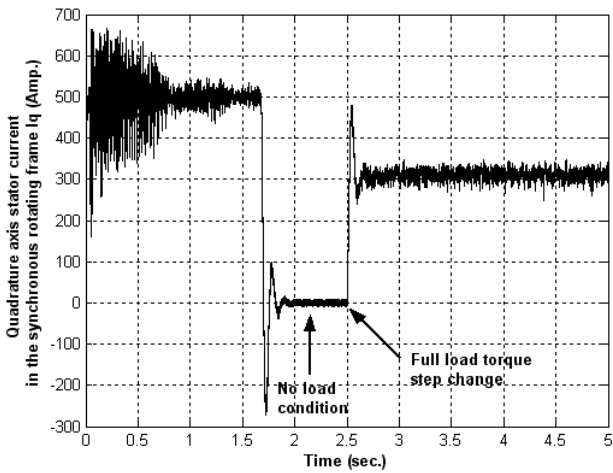

Fig.(17) Stator current q-component for a full-load torque step change at t=2.5 sec

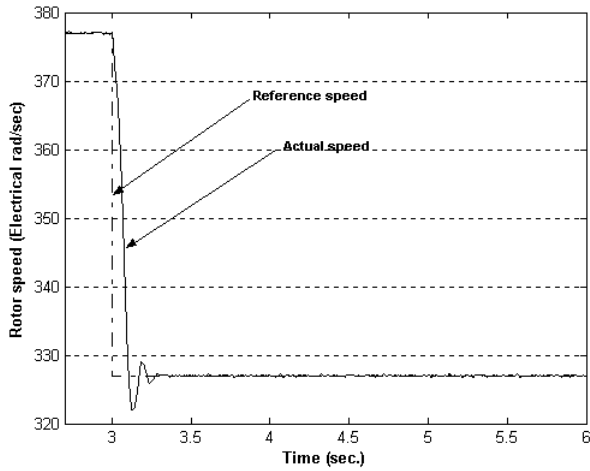

Fig.(18) Rotor electrical speed profile with step step down step change at full load condition.

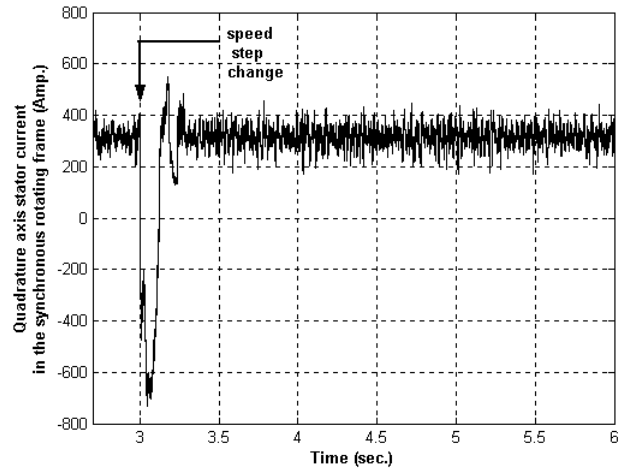

Fig. (19) Electromagnetic torque at full full load condition with a speed step down change at t=3 sec.

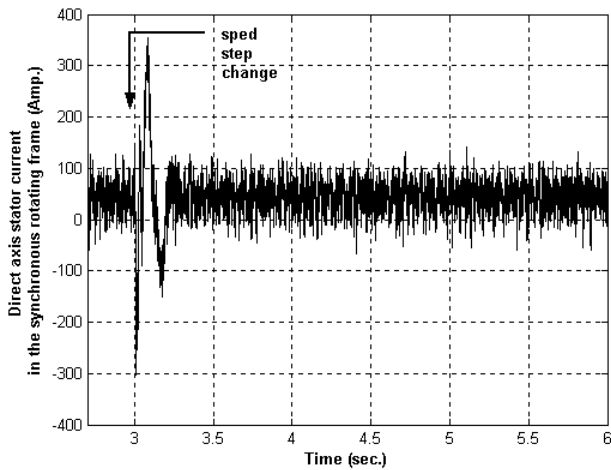

Fig.(20) Stator current d-component at full load condition with a speed step down change at t=3 sec.

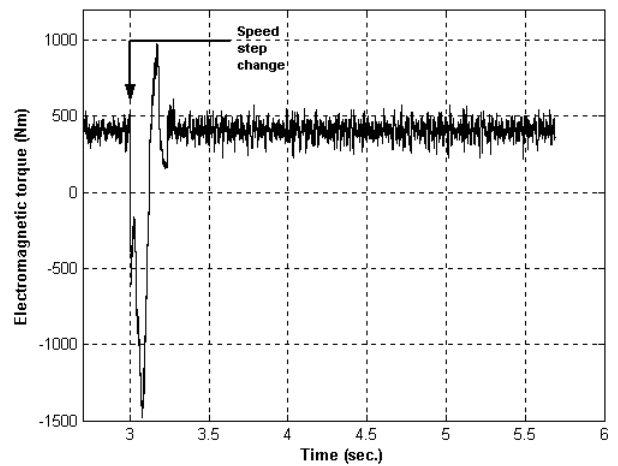

Fig. (21) Stator current q-component at full load condition with a speed step down change at t=3 sec.

- [3] M.A. Ouhrouche and N.Lechevin “*RT-Lab based real-time simulation of a direct field-oriented controller for an induction motor*”. Electronic, Real time simulation 18-Aug.-2002.
- [4] “*Digital signal processing solution for AC induction motor*” Application note BPRA043, Texas instruments, 1996.
- [5] R.Beguenane and M. Ouhrouche. “*MRAC-IFO Induction motor control with simultaneous velocity and rotor-inverse time constant estimation*”. IASTED International conference PES 2003.
- [6] E. Delaleau , J.P. Louis and R. Ortega. “*Modeling and control of induction motors*”. Int. J. Appl. Math. Comput. Sci. 2001, Vol.11, No.1, 105-129.
- [7] J. Jung and K.Nam. “*A dynamic decoupling control scheme for high-speed operation of induction motors*”. IEEE Transactions on industrial electronics, Vol. 46, No. 1 February 1999.
- [8] M. A. Ouhrouche, “*Simulation of direct field-oriented controller for an induction motor using MATLAB/SIMULINK software Package*”Proceeding of the IASTED International conference modelling and simulation (MS’2000), May 15-17,2000-Pittsburgh, Pennsylvania,USA.