

DESIGN OF DIGITAL TRANSIENT RECORDER

Dr. Abbas H. Abbas

University of Basrah College of Engineering Electrical Engineering Department

ABSTRACT:

The use of new advanced engineering tools to perform the daily work of the operators, such as Digital Transient Recorder (DTR) which gives a fast and enough information of any abnormal condition to the monitoring personnel which intern, without doubt enhance the control of the system. This device can use simulated or recorded or online signals in advance passed into a personal computer through an interface circuit and processed in the computer using a special software designed for this purpose and the obtained data can be stored for a long period of time according to the sequence events. This device can be used easily by any operator without special knowledge in power system. The Digital Transient Recorder is designed and tested and the obtained results are acceptable. The used language is VISUAL BASIC. The recorder records only the abnormal (transient) conditions.

Introduction:-

During the last few years, the restricted growth of electric transmission systems and increasingly higher power demands have forced utilities to operate power networks relatively close to their transmission limits; this has created new voltage stability problems. As the system load increases during the day, the voltage magnitudes throughout the network slowly decline [1].

Disturbance Types:-

Power system disturbances are of various types related to their different sources. Disturbances can be presented as steady-state load currents, dynamic operations as well as faults. The components that suffer from such disturbances are also of various types. Among the affected components, the protective relay is an important device for the safe and reliable operation of power systems [2].

In the sense of detrimental impact on protection, power system disturbances can be classified into two main categories: steady-state disturbances and transient disturbances. The main steady-state disturbances that can affect the performance of protective relays are harmonics and frequency deviation. The former results in distortion of the voltage or current waveform while the latter causes a variation in their period. The main transient disturbances that can affect the performance of protective relays are disturbances due to component switching. Such disturbances are due to the sudden change in steady state waveform in case of switching operations. Compared with long lasting disturbances such as harmonics and frequency deviation, component switching transients are of short duration but the deviation from the ideal waveform is typically larger [3].

Power system disturbances are, in the sense of source, the result of switching or operation of power system components; or in the sense of measurement, the transient or steady-state distortion in the waveforms of power system voltage and current; or in the sense of impact on power systems, the disturbances that degrade the performance of device, equipment or system. The presence of power system disturbances reflects the power quality in a system [4].

According to definition of disturbance, the transients in power system are

characterized by eigenvalues which have indifferent order of magnitude. Hence, the electrical power system is a multiple time scale system and the resulting differential equations are stiff [5]. The transient has detrimental impacts on the operation of protective relays. For the purpose of testing the possible performance of relays under transient conditions, it is necessary to evaluate the potential influence of the transients, based on which the classification of transients can be made [6].

In this paper a Digital Transient Recorder is designed and implemented.

Design and Analysis of Digital Transient Recorder:

In the last years, the transient problem became very important with modern development in all fields of power systems. Therefore, the direction is flowing in studying and analysis all features of transient, one of these is transient recorder. The need for such a system arose at the time when pre-strikes and restrikes in high-voltage vacuum switches were emerging as a potential problem for transformer, transmission lines and motor winding insulation, and in some cases arrester failure [6].

In this paper, we explain briefly each element used in transient recorder these elements assembled to design the components of transient recorder. The data from the

transient recorder is processed in the personal computer, this eliminates the need of a special interface card to control the transient recorder offers a cost sensitive solution for small systems.

Design of High Pass Filter:-

The electrical transients have high frequencies, therefore we need high pass filter. The second order of Butterworth low pass filter equation is [7]:

$$H(s) = \frac{1}{s^2 + \sqrt{2} s + 1} \quad \dots (1)$$

$s = j2\pi f$; f: Frequency in Hz

We convert the low pass filter to high pass filter by substituting $s \rightarrow \frac{\omega_c}{s}$

$\omega_c = j2\pi f_c$; f_c : Cut off frequency in

Hz

The high pass filter (HPF) at ω_c is

$$H(s)_{HPF} = \frac{1}{\left(\frac{\omega_c}{s}\right)^2 + \sqrt{2} \left(\frac{\omega_c}{s}\right) + 1} \quad \dots(2)$$

$$H(s)_{HPF} = \frac{s^2}{\omega_c^2 + \sqrt{2} \omega_c s + s^2} \quad \dots(3)$$

Transfer to the z transform by:

$$s = \frac{2(1 - z^{-1})}{T(1 + z^{-1})} \quad \dots(4)$$

T: Sampling time

Rearranging and solving of these equations the equation of high pass filter is:

$$H(z) = \frac{4(1 - 2z^{-1} + z^{-2})}{[\omega_c^2 T^2 + 4 + 2\sqrt{2}\omega_c T] + [2\omega_c^2 T^2 - 8]z^{-1} + [\omega_c^2 T^2 - 2\sqrt{2}\omega_c T + 4]z^{-2}} \quad \dots(5)$$

This digital filter can be realized by specification of a difference equation obtained from the transfer function H(z) given by:

$$H(z) = \frac{Y(z)}{X(z)} \quad \dots(6)$$

Y(z): Output

X(z): Input

Cross multiplying between Eq. (5) and

Eq. (6) gives:

$$4X(z)[1 - 2z^{-1} + z^{-2}] = Y(z) [\omega_c^2 T^2 + 4 + 2\sqrt{2}\omega_c T] + Y(z) [2\omega_c^2 T^2 - 8]z^{-1} + Y(z) [\omega_c^2 T^2 - 2\sqrt{2}\omega_c T + 4]z^{-2} \quad \dots(7)$$

and taking the inverse z transform we find:

$$4[x(n) - 2x(n-1) + x(n-2)] = y(n) [\omega_c^2 T^2 + 4 + 2\sqrt{2}\omega_c T] + y(n-1) [2\omega_c^2 T^2 - 8] + y(n-2) [\omega_c^2 T^2 - 2\sqrt{2}\omega_c T + 4] \quad \dots(8)$$

By rearranging and scaling, y(n) can be realized by the following high pass filter equation:

$$y(n) = [4[x(n) - 2x(n-1) + x(n-2)] - [2\omega c^2 T^2 - 8]y(n-1) + [\omega c^2 T^2 - 2\sqrt{2}\omega c T + 4]y(n-2)] / [\omega c^2 T^2 + 4 + 2\sqrt{2}\omega c T] \dots(9)$$

Discrete-Time Fourier Series:-

A real periodic discrete-time signal $x(n)$ of period N can be expressed as a weighted sum of complex exponential sequences. Because of the fact that sinusoidal sequences are unique only for digital frequencies from 0 to 2π , The expansion contains only a finite number of complex exponentials as follows [8]:

$$x(n) = \frac{1}{N} \sum_{K=0}^{N-1} X(K) e^{jK\omega_o n} \text{ for all } n \dots(10)$$

Where the coefficients of the expansion $X(K)$ and the fundamental digital frequency ω_o are given by

$$X(K) = \sum_{n=0}^{N-1} x(n) e^{-jK\omega_o n} \text{ for all } K \dots(11)$$

Where,

$$\omega_o = \frac{2\pi}{N}$$

Equation (10) and (11) are called the Discrete Fourier Series (DFS) pair. The expression given in Eq (10) is referred to as the exponential form of the Fourier series for a periodic discrete-time signal. Equation (11) is sometimes written in the following equivalent form:

$$X(K) = \sum_{n=0}^{N-1} x(n) \left[\cos(K\omega_o n) - j\sin(K\omega_o n) \right] \dots(12)$$

Equation (12) is written in two forms :

$$X(K)_R = \sum_{n=0}^{N-1} x(n) \cos(K\omega_o n) \dots(13)$$

$$X(K)_I = \sum_{n=0}^{N-1} x(n) \sin(K\omega_o n) \dots(14)$$

Where,

$X(K)_R$: Real of $X(K)$

$X(K)_I$: Imaginary of $X(K)$

The Hardware :

This device should be implemented using industrial computer. However, industrial computer relatively expensive, so a personal computer is used. The minimum requirements of the used computer are:

4.3 GB space on a hard disk, 64 MB RAM, full cash memory and minimum speed is 400 MHz

The interface is done via ISA bus with card interfacing which shown in Fig.(1).

The card consists of several stages: with filter or without filter, sample and hold stage, operational amplifier stage, Analog to Digital Converter and Buffers, which shown in Fig.(2).

Sample and Hold (S&H):-

The continues-time signal can be computed from the sampling signal by the interpolation formula

$$f(t) = \sum_{k=-\infty}^{\infty} f(kh) \frac{\sin \omega_s (t - kh) / 2}{\omega_s (t - kh) / 2} \dots(15)$$

Where ω_s is the sampling angular frequency in radians per second (rad/s).

Shannon Reconstruction: for the case of periodic sampling of band-limited signals, it follows from the sampling theorem that a reconstruction is given by (15). this reconstruction is called the Shannon reconstruction. Equation (15)

defined as an inverse of the sampling operation, which can be considered as a linear operator.

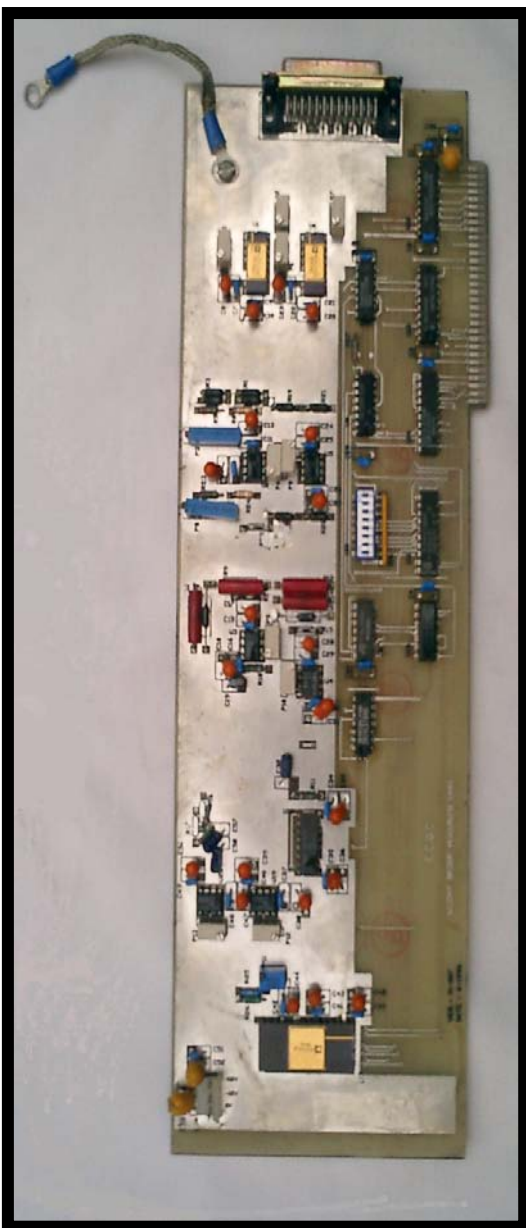

Figure 1 Interfacing Card

Operational Amplifier:-

The operational amplifier, which should be of high band frequency to avoid harmonics frequencies, is connected between sample & hold and A/D converter to control the magnitude of the voltage signal from S & H and maintain its shape before feeding it to the limited input voltage AD converter.

Analog to Digital converter:-

Analog to Digital converter is AD574A. The AD574A is a complete 12-bit successive-approximation analog – to - digital converter with 3-state output buffer circuitry for direct interface to an 8-bit or 16-bit microprocessor bus. A high precision voltage reference and clock are included on-chip, and the circuit guarantees full-rated performance without external circuitry or clock signals.

Addressing Mode:-

The ISA bus has free addresses from 300 to 31F. Using the board with an address within the range mentioned will mostly perform a different, factory controlled, application. To cope with this problem, the boards addresses are changed by using logic switches

The Software:

A suitable software is designed to meet the requirements of all the modes of operation which are:

1. each line separately
2. all the three lines that are a, b, and c lines.

Also whether the recorder needs to be used as an event recorder only, or to graph the abnormal condition. The equipment can be used to read the data and to test it if required. Processing the input data every 2.86 MB by testing it. If there is disturbance in the data, the program will save the data otherwise deleting it. The saved data can be continue several day before deleted or replaced by a new event. The time required to process the above amount of data is small because of the transient period is short. It can be controlled via the A/D converter.

Results :

The program can be activated by typing the password and a "welcome" phrase. The main information . consists of the following :

- No. of port: which indicates the port addresses.
- Com. port: communications port (com1 and com2), manufacturer is standard port types in PCI bus.
- No. of devices: many inputs can be used at the same time.
- Delay: speed counter.
- Selection of phases: phase A or phase B or phase C or the three phases.

Figures from 3- 8 show some of the program information and results that can be obtained.

Conclusions:

An adequate software is designed to meet all kinds of possible transients that can occur on the system (phase A, phase B, phase C and three phases).

The designed recorder can be used easily by any operator without any special qualification or knowledge in the field of power system analysis. The events can be saved according to the sequence of happening and can be used for any time when the device is used on line.

Also according to the abilities of this device and the choices of the modes of

operation made it simple to use either online or offline for the training of personal. The device can be used in any Electrical Power Utility.

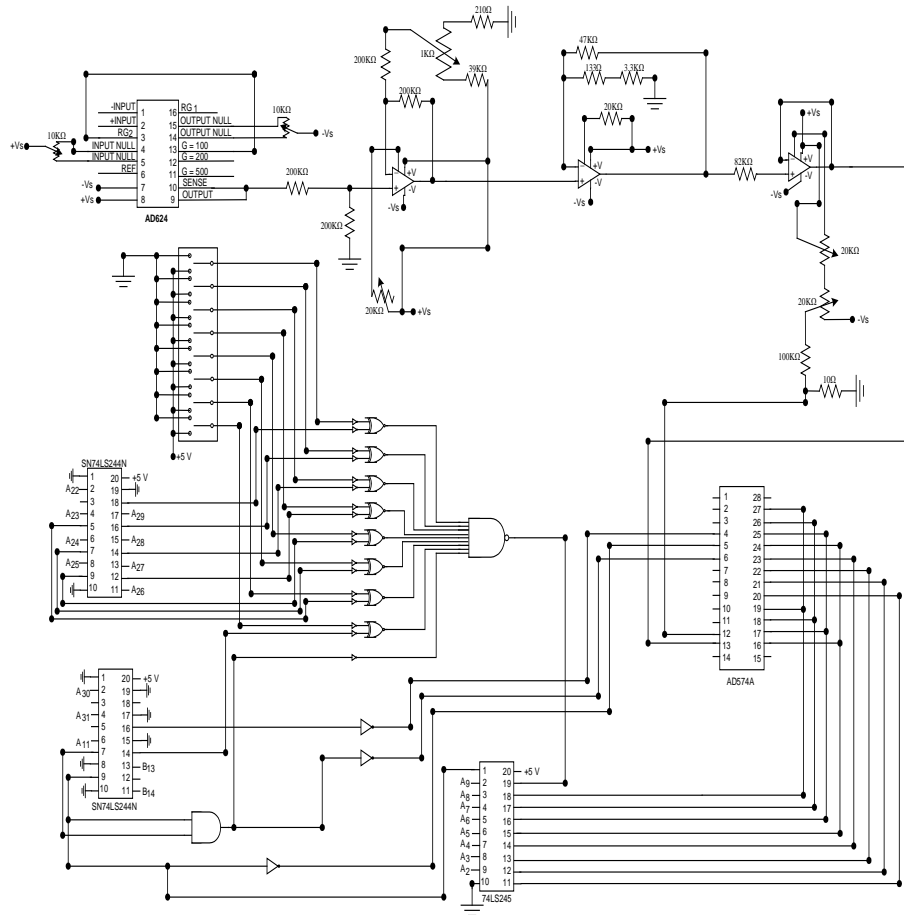

Figure 2 The Diagram of the interface card



Figure 3 Infoation page

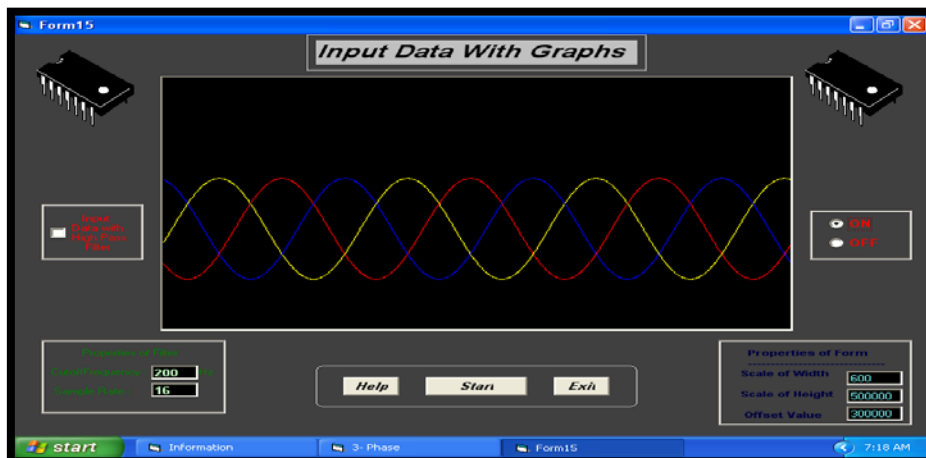

Figure 4 Input Data with graphs



Figure 5 Input Data with graphs

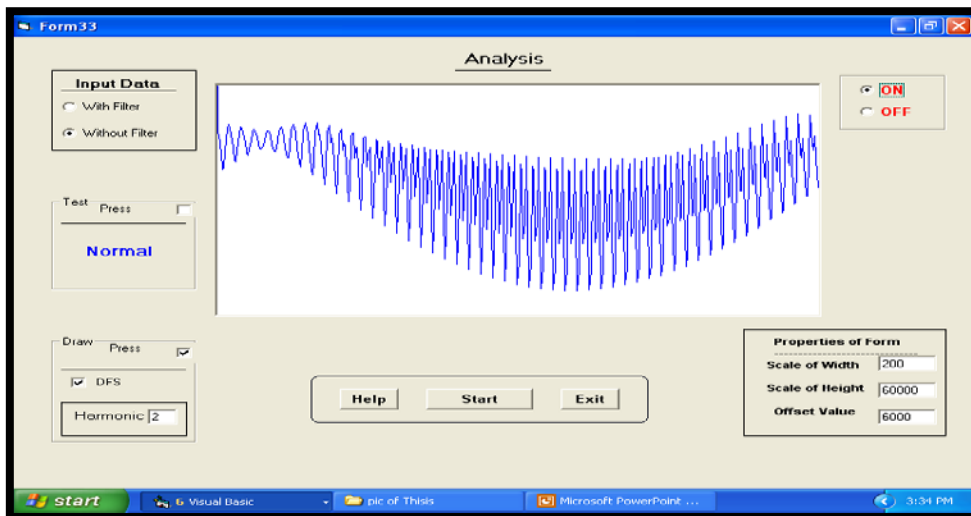

Figure 6 Analysis with second harmonic

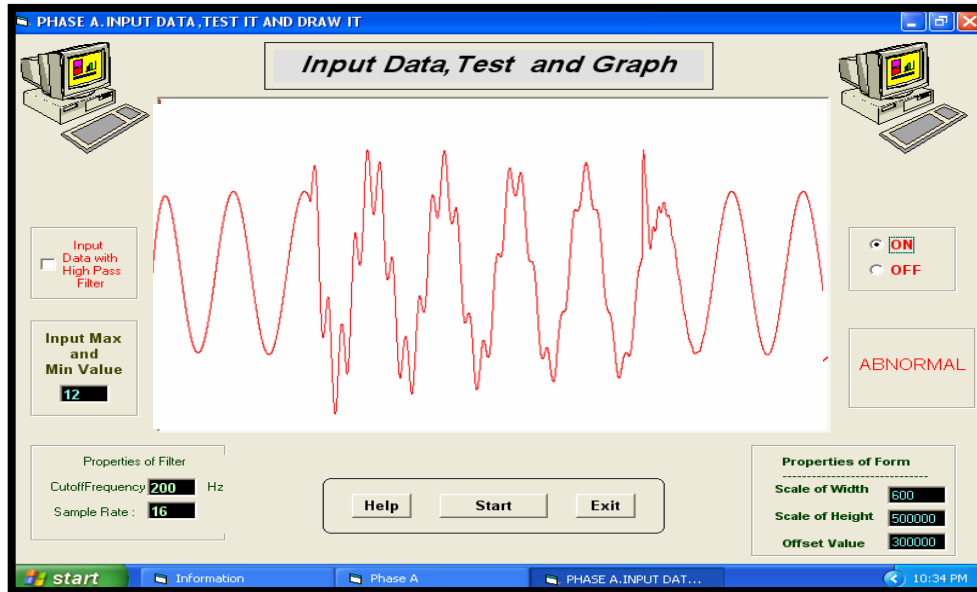

Figure 7 Input Data, Test and Graph with abnormal signal

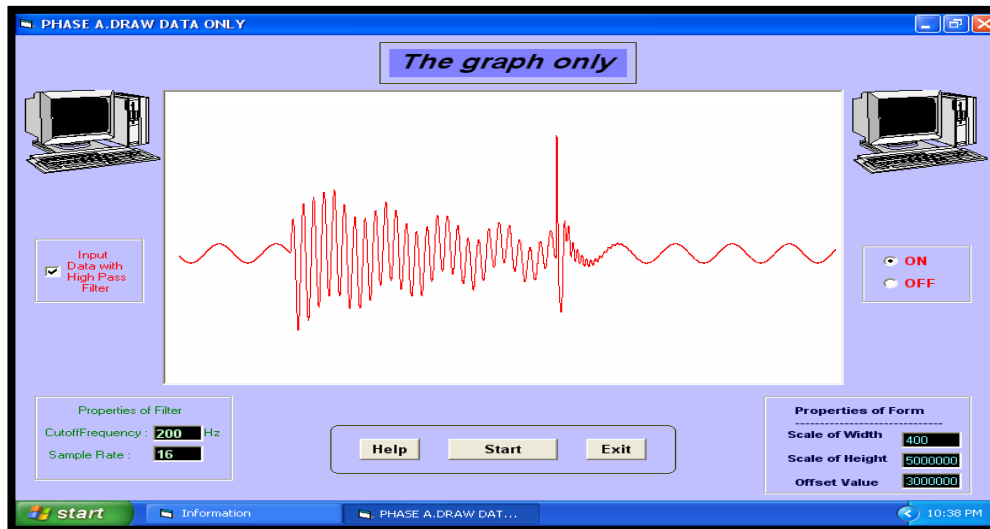

Figure 8 Graph only with filter

References:

- [1] C. A. Canizares, "***Voltage Collapse and Transient Energy Function Analysis of AC/DC Systems***", PhD thesis, Electrical and Computer Engineering at the University of Wisconsin–Madison,1991.
- [2] C. J. Rozell, Don. H. Johnson and R. M. Glantz , "***Information Processing During Transient Responses in the Crayfish Visual System***", Neurocomputing Conference. June 2003. Rice University Huston.
- [3] Wenzhe Lu and A. Keyhani, "***Sensorless Control of Switched Reluctance Motors Using Sliding Mode Observers***". Electric Machines and Drives Conference, 2001. IEMDC 2001. IEEE International Volume , Issue , 2001 Page(s):69 – 72.
- [4] F. Wang, "***Power Quality Disturbances and Protective Relays Component Switching and Frequency Derivation***". PhD thesis Chalmers University of Technology Sweden March 2001.
- [5] C. J. Rozell, Don. H. Johnson and R. M. Glantz , "***Information Processing During Transient Responses in the Crayfish Visual System***", In Computational Neuroscience '02,Chicago, IL year 2003 vol 52.
- [6]F. Martzloff, "***High-Speed Transient Recording System***", General Electric TIS Report 68-C-019, January,1968.
- [7] Lonnie C. Ludeman "***Fundamentals Of Digital Signal Processing***", J.Wiley and Sons, Library of Congress Cataloging in Publication Data, 1987.

تصميم مسجل الحالة العابرة

د.عباس حافظ عباس

كلية الهندسة – جامعة البصرة – قسم الهندسة الكهربائية

الملخص:

إن استخدام الأجهزة الهندسية المتطورة يسهل عمل المشغلين العاملين في منظومة القدرة الكهربائية مثل جهاز تسجيل الحالة العابرة الرقمي الذي بإمكانه تزويد كادر المراقبة في غرف السيطرة بمعلومات كافية وسريعة لأية حالة غير طبيعية (كالحالة العابرة) الأمر الذي من شأنه تحسين أداء منظومة القدرة.

هذا الجهاز بإمكانه استخدام إشارة محاكاة أو يربط مباشرة بالمنظومة حيث يتم إدخال الإشارة الى الحاسب الشخصي عن طريق البطاقة التداخلية وتعالج هذه الإشارة باستخدام برامج تخصصية صممت لهذا الغرض، ويتم تخزين البيانات الناتجة والتي تمثل الحالات غير الطبيعية لفترة طويلة وحسب تسلسل الحدث يتم استدعاؤها عند الحاجة.

بالإمكان التعامل مع الجهاز بسهولة من قبل اي مشغل دون معرفة خاصة بمنظومة القدرة

لقد تم تصميم وتنفيذ الجهاز واختباره وكانت النتائج مقبولة.