

Design and Implementation of Computerized control room

Hawrra H.Abbas Al-Rubiae
Computer engineering. The University of Kerbala

Abstract

For any control system there is two basic operations the first one picking up the information (data) from around environment (such as factory) by using special electronic devices such as sensors to handle these data, the second make same action to the connected devices according to the result of these information's. In this paper we design and implement computerized control system (contain H/W interface part and monitoring program) for doing the above operations.

الخلاصة

لأي نظام سيطرة توجد مرحلتين للعمل الأولى جمع المعلومات أو البيانات بواسطة أجزاء الكترونية تسمى المتحسسات ومن ثم معالجة المعلومات المطلوبة ومن ثم إصدار فعل معين للأجهزة الموصلة لنظام السيطرة اعتمادا على المعلومات المجموعة في البحث الحالي قمنا بتصميم وتنفيذ منظومة سيطرة حاسوبية متكاملة للقيام بالمهام الموضحة أعلاه.

1-Introduction

The migration of technology to the digital world has increased the types of digital applications. Digital I/O applications include control applications, video testing, chip verification, and pattern recognition. Just as there are many types of digital I/O applications, there are many different types of digital I/O data acquisition devices that can be used. The type of digital I/O device required for our application will depend on how data needs to be transferred between the computer and the external (peripheral) device.[9]

One of the most important digital systems is the control system where the interface card is essentially a digital input/output device used to interface a personal computer with the outside world. A personal computer is a powerful tool and has an infinite amount of capabilities and applications. The interface card extends these capabilities to the outside world. The board can be used for both controlling and monitoring processes through software routines and sensors. The interface card is inserted into the personal computer's bus through an buses such as the EISA or VESA buses or through the ports such as the parallel or serial ports. A connector is attached to the board to allow it to connect with the devices, which need to be controlled or to connect different type of sensors such as (temperature, light) to the personal computer through ADC (Analog to Digital Conversion) on this board to make the user apple to monitor these sensor by software.[8]

2-The system components

The understand any system we must first understand the basic features of the components used to built this system .

2-1 Computer Buses

Bus (computer), in computer science, a set of hardware lines-wires-used for data transfer among the components of a computer system. A bus is essentially a shared highway that connects different parts of the system including the microprocessor; disk-drive controller, memory, and input/output ports-and enables them to transfer information. Usually supervised by the microprocessor, the bus is, in computers such as the Apple Macintosh and IBM and compatible models, specialized for carrying different types of information. One group of wires (actually, traces on a printed circuit board), for example, carries data; another carries the addresses (locations) where specific information can be found; yet another carries control signals to ensure that the different parts of the system use their shared highway without conflict. Buses are characterized by the

number of bits they can transfer at a single time. [5] A computer with an 8-bit data bus, for example, transfers 8 bits of data at a time, and one with a 16-bit data bus transfers 16 bits at a time. Because the bus is integral to internal data transfer and yet computer users often need to add extra components to the system, most microcomputer buses allow for expansion through one or more expansion slots (connectors for add-on circuit boards). Such boards, when they are added, make an electrical connection to the bus and effectively become part of the system. PC buses are the fundamental data "highways" on the system board. There are different types of buses such as ISA,EISA,VESA,PCI bus each one has it own features as shown in table bellow.[6][4]

Bus Type	Number Bits	CPS	Speed	No. Connectors
ISA	8	4mb/s	8.25MHz	31 pairs
EISA	16	8mb/s ?	8.25MHz	49 pairs
MCA	32	unk	10MHz	93
VESA Local Bus	32	107MB/s	50MHz	49+36
PCI	32	132MB/s	33MHz	Unk

2-2 Parallel Port Basics

Eight bits of data are transferred at a time over PC parallel ports. Data is sent using +5 volts and 0 volts to represent a 1 or a 0 data bit. As you might expect, data can be transferred relatively fast in this manner. The disadvantages of this method is that more wires are needed and that most common parallel ports can only work reliably at distances of under 20 feet. Speed variations are: 250Kb, 500Kb, and 1Mb.[10]

2-3 Analog to Digital and Digital to Analog conversion

The measurements and signals that occur in nature or in man-made devices are analog or digital in form. Analog quantities can take on any values within a given range. Most physical measures (i.e., temperature, length, voltage) are analog. Digital quantities may take only specific values within a range. The binary signals that computers and telecommunications systems use are digital signals. Devices that are able to take analog signals and convert them to digital signals are called analog-to-digital (A/D) converters. Likewise, digital-to-analog (D/A) converters convert digital signals to analog signals.[2]

A/D and D/A converters have many applications and are found in a wide variety of common devices, such as radios, instruments, and appliances. Because most of our computational devices are digital, perhaps the most important use for A/D and D/A converters is to allow digital computers to interact with an analog world. In a microcomputer, for example, an A/D converter is used to convert the analog position of a joystick to digital coordinate values. Computerized control systems and laboratory instrumentation systems are other significant industrial uses for A/D and D/A converters.[1]

A variety of ADCs exist on the market today, with differing resolutions, bandwidths, accuracies, architectures, packaging, power requirements, and temperature ranges, as well as hosts of specifications, covering a broad range of performance needs. so there are different type of A/D according to there architecture such as Flash converter ,Pipelined ,Successive approximations ,Sigma-delta.[1][3]

2.2.1 The interface of ADC0804LCN

The ability to convert analog signals to digital and vice-versa is very important in signal processing. The objective of an A/D converter is to determine the output digital word corresponding to an analog input signal.

The A/D converter fig (1) operates on the successive approximation principle. Analog switches are closed sequentially by successive-approximation logic until the analog differential input voltage $[V_{in(+)} - V_{in(-)}]$ matches a voltage derived from a tapped resistor string across the reference voltage. The normal operation proceeds as follows. On the high-to-low transition of the WR input, the internal SAR latches and the shift-register stages are reset, and the INTR output will be set high. As long as the CS input and WR input remain low, the A/D will remain in a reset state. Conversion will

start from 1 to 8 clock periods after at least one of these inputs makes a low-to-high transition. After the requisite number of clock pulses to complete the conversion, the INTR pin will make a high-to-low transition. This can be used to interrupt a processor, or otherwise signal the availability of a new conversion. A RD operation (with CS low) will clear the INTR line high again. The device may be operated in the free-running mode by connecting INTR to the WR input with CS=0.

Since this is an 8-bit A/D converter, a voltage from 0-5V. O will be represented as 0000 0000 (0 in decimal) and 5V is represented as 1111 1111 (256 in decimal). To convert a value X volts to decimal, use the

following formula:

$$\frac{X * 5.0}{256}$$

To get a better resolution, and display the value as a floating point number, you can multiply the numerator by a factor of 100, 1000 etc. and then print the voltage accordingly.[1][2]

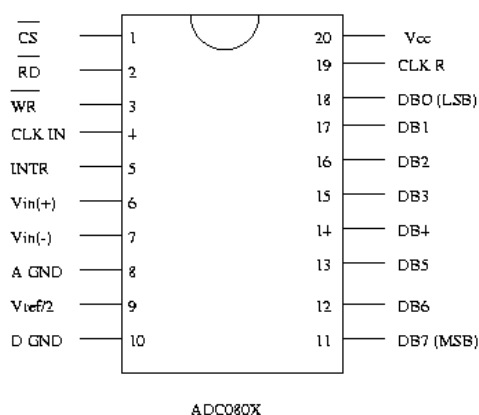

Figure (1) ADC0804LCN

2.4 The 8255

The 8255A is a programmable peripheral interface (PPI) device designed for use in Intel microcomputer systems. Its function is that of a general purposes I/O component to Interface peripheral equipment to the microcomputer system bus. The functional configuration of the 8255A is programmed by the systems software so that normally no external logic is necessary to interface peripheral devices or structures. The 8255A contains three 8-bit ports (A , B, and C). All can be configured in a wide variety of functional characteristics by the system software but each has its own special features or personally to further enhance the power and flexibility of the 8255A.[11]

2-5 Relays

A relay is an electrically operated switch. Current flowing through the coil of the relay creates a magnetic field which attracts a lever and changes the switch contacts . The coil current can be on or off so relays have two switch positions and they are double throw (changeover) switches.

Relay allow one circuit switch a second circuit which can be completely separate from the first. For example a low voltage battery circuit can use a relay to switch a 230V AC mains circuit. There is no electrical connection inside the relay between the two circuits, the link is magnetic and mechanical.

The coil of relay passes a relatively large current, typically 30mA for a 12V relay , but it can be as much as 100A for relays designed to operate from lower voltages. Most (chips) cannot provide this current and a transistor is usually used to amplify the small IC current to the larger value required for the relay coil. [12]

2-6 Sensors

a component that can detect changes in its surroundings e.g. a light sensor can detect changes in brightness, a heat sensor can detect changes in temperature. Sensors are often connected to computers in order to capture data about a particular environment or situation so in general we

can define the sensor as: A device that responds to a physical stimulus (heat, light, sound, pressure, motion, flow, and so on), and produces a corresponding electrical signal.[11]

3- The System Implementation

This is a simple computerized control system which consist two part the hardware interface system and the user software for control process.

3.1 Hardware

The system contain two hardware parts on to check the change of temperature by the sensor and another to ON/OFF the connected devices.

Fig (2) show the hardware control card interface for alarm system (this interface tested by Electronic workbench v5.2 and ORCAD9.2 hardware test programs) connected to EISA bus to collect data from temperature sensor the Dallas DS1620 fig (3) integrated circuit. It is an 8 pin chip that has a built in system that measures the temperature and converts the reading into a 9 bit binary value. It has an accuracy of 0.5 degrees C and a range of -55 to 125 C. The temperature reading is updated about once per second to generate input voltage through the DQ connected to A/D (ADC0804LCN principle of it is work explain in chapter two) to convert it to digital value read by the CPU through 74LS 245 bus transfer which activate by the signal INTR from the A/D (end of conversion signal) and Y0 from 74LS138 decoder, the INTR signal also used to reset the sensor for new reading. This converted data tested by the software program to alarm the user if the temperature is over the acceptable range by enable the speaker at 244 buffer.

Fig (4) show the hardware circuit that connected to LPT port at address 378h too control the ON/OFF for (!2) device through relays connected to port (A), and port (C) from the PPL 8255 controller .The 8255 has three ports (A, B, C) and command register to program the 8255 each one of them have different address (by changing the values of A0,A1 address lines connect to 8255 from address bus through the LPT port) to handle it :

Port A at address 378h

Port B at address 379h

Port C at address 37Ah

Command register at address 37Bh by it the 8255 programmed at mode (0) of operation and port A,C as output port.

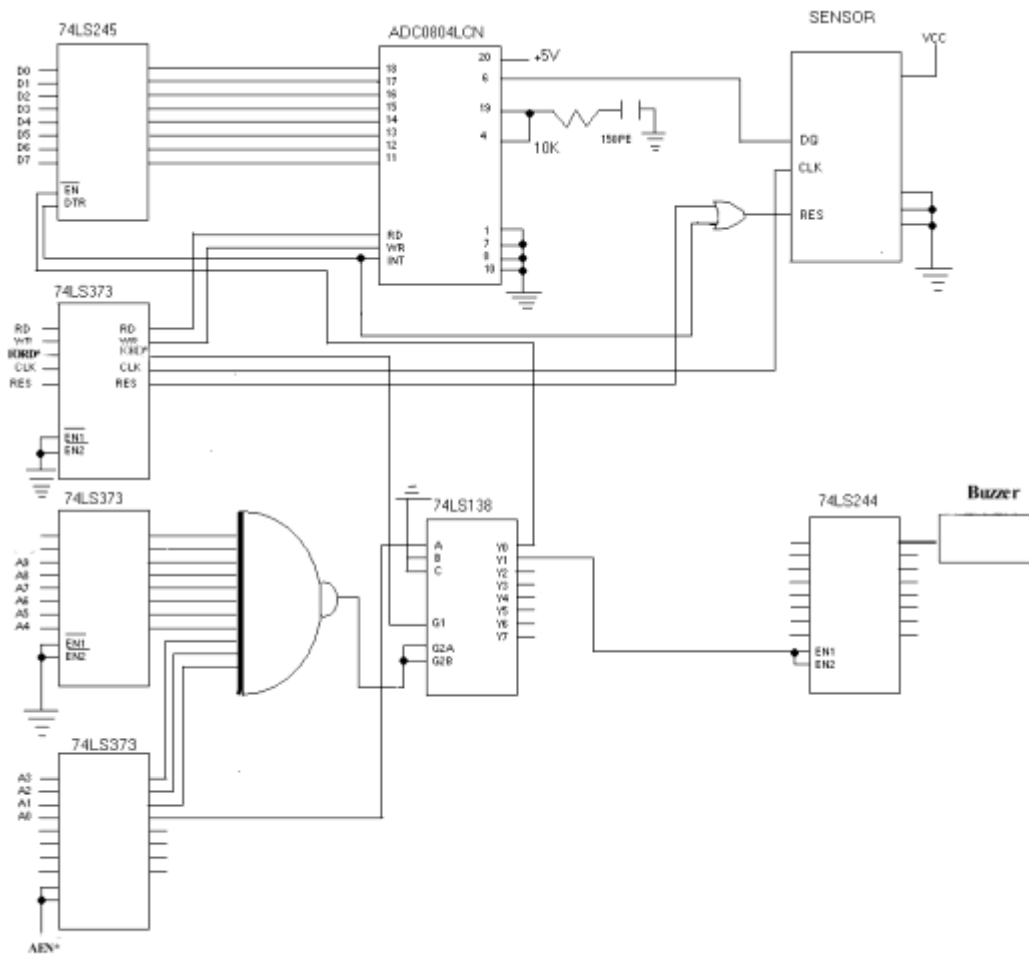

Figure (2) the Interface card for alarm system

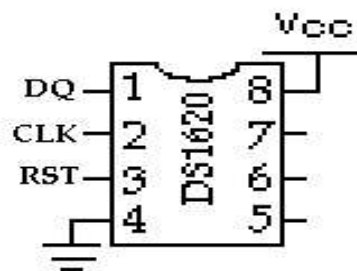

Figure (3) the DS1620 sensor

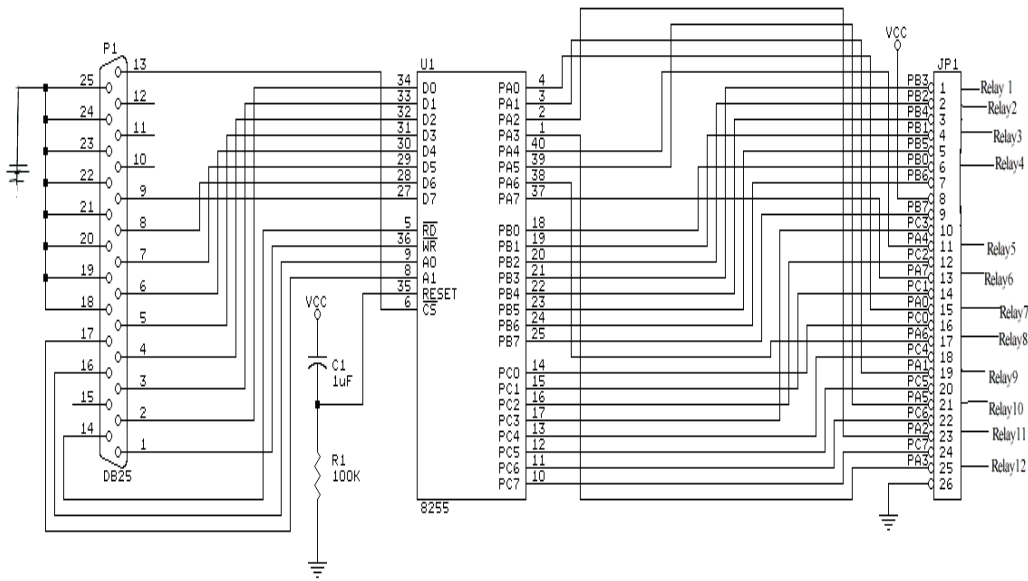

Figure (4) the Interface Circuit for ON/OFF devices through the Relays

3.2 Software

Fig (5-a) shows the program by it the user can control the operation of reading or collection data from the temperature sensor to alarm the user if a change is happen in the environment heat by this program.

As we seen our interface program based on dealing with the EISA bus through the address 300h and 301h so we need INPUT and OUTPUT functions which only found in C, C++ languages were not implemented in VB. These functions are crucial for PC hardware developers and programmers because they allowed us to read and write to ports. Thus without INPUT or OUPUT we can't read from or write to our device.

There is a way around this, using a DLL. As the name implies, DLLs allows VB to link (a step before compiling) code (libraries we coded up in another language like Delphi, Borland C++ or Microsoft's Visual C++) during run-time (dynamically). VC++ has port I/O (input and output) read/write functions. Also VC++'s compiler allows us to create DLLs (in addition to executable EXE files).

Fig (5-b) shows the program by it the user can control the operation of the devices through the relays to make them all OFF or all ON or select any one from these to make it ON/OFF.

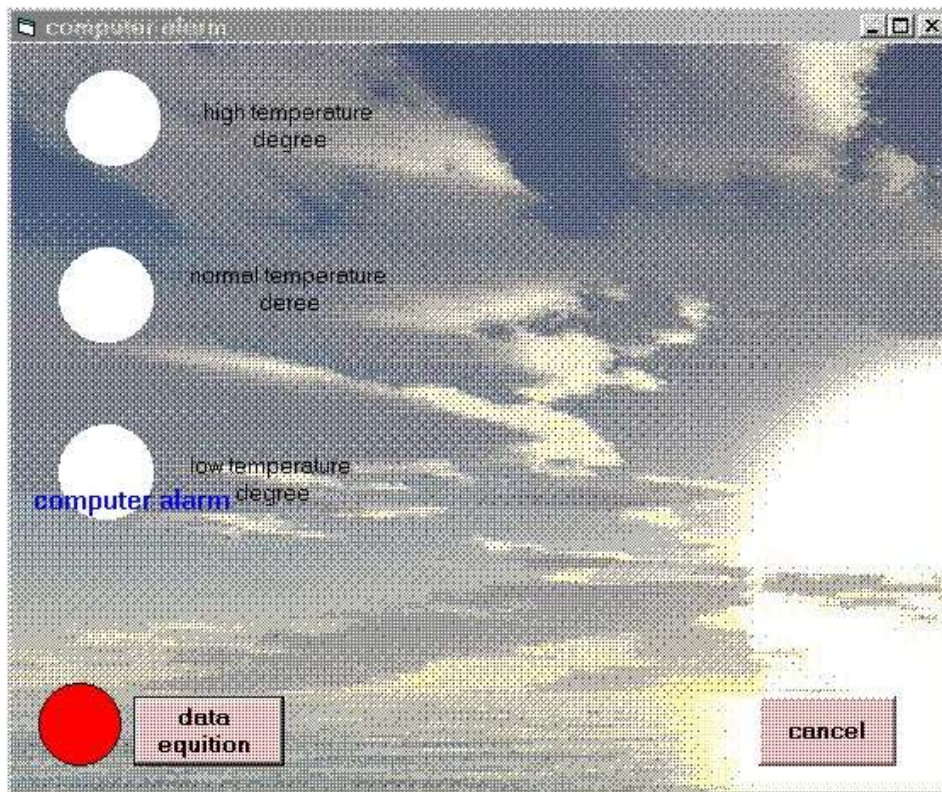

Figure (5-a) The alarm program

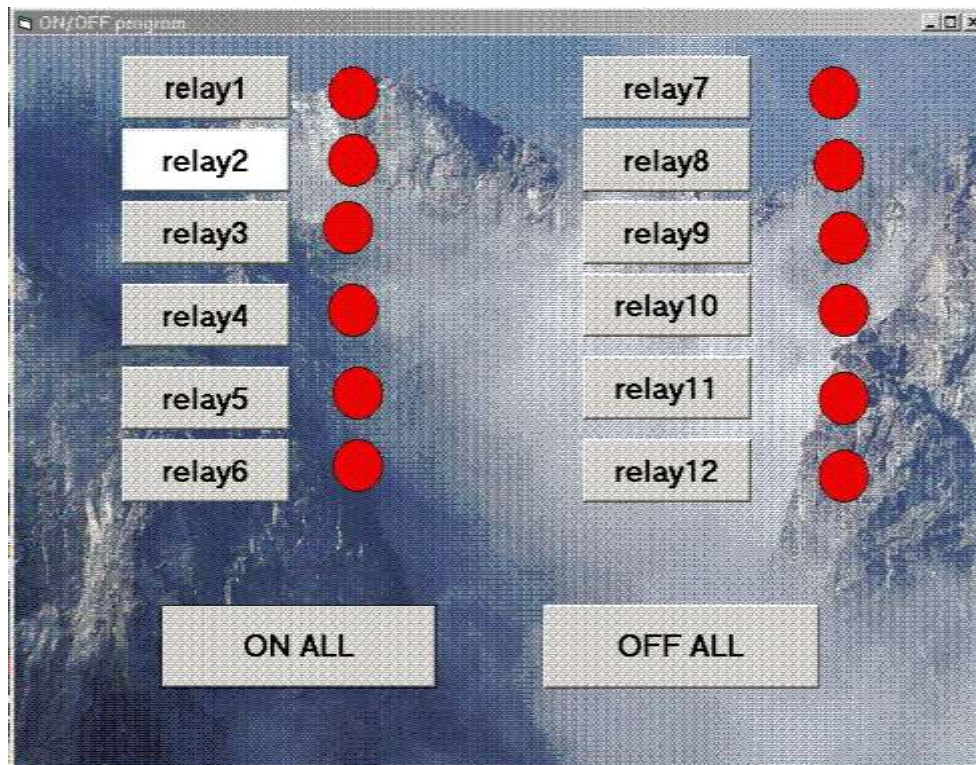

Figure (5-b) The ON/OFF devices program

4- Conclusion

The basic operation of the control system is collection the data from the environment we want it be under control and test these data to handle it by the control system program, so there is different types of collection devices (sensor) for different environment parameters(such as temperature, pressure, light ...ect) ,after that according to these data the suitable action taken to handle the devices connected to the system such as ON or OFF them.

We implement a very simple EISA card interface to collect a data from one of general applications collection device(temperature sensor)and handle it to check the environment effect(temperature) on this sensor to alarm the operator of the control system if any error happen or change and make him able to do any action.

References

- [1] The engineering staff of analog device "Analog-Digital conversion handbook" inc. Englewood cliffs, nj: prentice hall 1996.
- [2]Walt Kester. Norwood," practical analog design techniques "MA: analog devices, inc. 1995.
- [3] high speed design techniques, edited by Walt Kester. Norwood , MA. Analog devices, Inc., 1996.
- [4] Peter Norton, "peter Norton inside pc" prentice hill, 1996.
- [5] B.Pery," Intel family" prentice hall, 2000.
- [6]B.A.Protopapas," microcomputer hardware design", prentice hall, 1990.
- [7] Lou Tylee,"courenotes for learn visual basic6",1998.
- [8] <http://www.lguaua lab.com>," temperature sensor collecting data" 2004.
- [9] <http://www.national instrument.com>" digital I\O application, 2003.
- [10]-[www. Beyondlogic.org/spp/parallel.htm](http://www.Beyondlogic.org/spp/parallel.htm),"parallel port basic",1999
- [11] Michael S.combs, MS," Construction of Intel 8255 Based interface", The eclectic Journal foe Engineering Technology ,Volume 4, 2000
- [12] John Bird," Electrical and Electronic Principle and Technology", Newnes, second edition, 2003