

# Wavelet Packet Transform Based Power Quality Analysis

Dr. Adel A. OBED

Electrical Department, College of Engineering, Basrah University.  
adelrazaan@yahoo.com

## Abstract:

This paper presents a diagnostic technique for power quality analysis against different disturbances in electrical power source. The presented technique utilizes a wavelet packet transform (WPT)-based a proposed algorithm for monitoring and detection various disturbances occurring in supply voltage signal and in supply frequency. The values and the time locations for low and high frequency coefficients are determined up to level six and compared with a threshold determined from the operation of healthy source. The proposed technique is tested on certain cases and the simulated results indicate that this technique is effective for detecting and monitoring different mentioned disturbances.

**Keywords:** Wavelet packet transform, Disturbances monitoring and detection, Power quality

## تحليل جودة القدرة باعتماد تحويله حزمة الموجة

د. عادل احمد عبيد  
قسم الهندسة الكهربائية- كلية الهندسة- جامعة البصرة

### الخلاصة :

يقدم هذا البحث تقنية مميزة لتحليل جودة القدرة تجاه مختلف الاضطرابات في مصدر القدرة الكهربائية. تستخدم هذه التقنية برنامج مقترح لمراقبة وكشف مختلف الاضطرابات خلال اشارة فولتية المصدر وتردده باعتماد تحويله حزمة الموجة. تم حساب القيم والموقع الزمني لمعاملات الترددات الواطئة والعالية ولغاية المستوى السادس وقورنت مع قيم بدائية تم الحصول عليها من حالات تشغيل لمصدر خالي من الاضطرابات. بينت نتائج المحاكاة بأن التقنية المستخدمة فعالة لمراقبة وكشف مختلف الاضطرابات المشار اليها.

## 1- Introduction

With the development of power industry and the wide applications of solid state switching power supplies and to avoid undesirable stresses in electrical loads which may lead to many modes of failures, it is necessary to protect it from different disturbances introduced from the source. Moreover the need for condition monitoring has increased recently because of the widespread use of automation and consequent reduction in direct man-machine interface to supervise any system operation. Monitoring is the graphical tend of the load operation for the purpose of detection, analysis and correction of the system problems before the failure takes

place [1]. The detection and correction of any disturbance leads to increasing load availability and performance avoiding damage, reducing spare parts, inventories and breakdown maintenance [2].

The nature of the output of power source, especially solid state switching power supply, involves a variation in the electric voltage and current, such as voltage sag, swell, dips, fluctuation, momentary interruption, harmonics, and transient oscillations, causing malfunction, instabilities, short lifetime, failure of the electrical equipments [3-8]. These variations lie under power quality problem and to improve power quality, it is required

to find ways to mitigate the source power supply.

A traditional approach for power quality uses fast Fourier transform (FFT) to analyze harmonic contents contained in the power signal [9,10]. However FFT is basically a steady state analysis approach. An attempt to develop an algorithm based on discrete stationary wavelet transform (SWT) is used to determine the amplitude of the harmonics present in the power signal from the coefficients computed by continuous wavelet transform (CWT) and wavelet-neurofuzzy combined system [11,12]. The separate FFT routine and several neural networks are required along with the features extracted from the wavelet multiresolution analysis.

This paper aims to propose a diagnostic technique for monitoring and detection of the variations of the power source signal (voltage sag, swell, interrupt, spike, harmonics) and the variations in source frequency, based on wavelet packet transform. The WPT is used to calculate the low frequency coefficients up to level six and up to level two for high frequency coefficients and to calculate the energy at these levels through the Shannon entropy formula. The high frequency details,  $dd^2$ , is used to construct an algorithm for disturbances analysis. The simulation results give a trip signal at instant with less than one cycle of the disturbance in all cases studied.

## 2- Wavelet Packet Transform (WPT)

Wavelet packet transform is a type of wavelet-based signal processing in a way that each level of resolution (octave)  $j$  consists of  $2^j$  boxes generated by a tree of low pass filter (LPF) and high pass filter (HPF) operations. The frequency bandwidth of a box decreases with growing octave number i.e. with increasing octave number, the frequency resolution becomes higher while the time resolution is reduced. Starting with a discrete signal  $f[n]$  with length  $N$ , the first level,  $j=1$ , decomposition produces two subbands

discrete signals  $a^1[N/2]$  and  $d^1[N/2]$  as follows [2,13]:-

$$a^1[n] = \sum_{k=0}^{N-1} g(k) f(n-k) \quad (1)$$

$$d^1[n] = \sum_{k=0}^{N-1} h(k) f(n-k) \quad (2)$$

where  $a^1[n]$  and  $d^1[n]$  are the first level approximations and details respectively,  $k$  is an integer and  $g(n)$ ,  $h(n)$  are the LPF and HPF associated with a selected mother wavelet function respectively. The output of both LPF and HPF are downsampled by two at the end of each filtering stage in order to increase the frequency resolution and to ensure the time localization of each frequency subband. The second level of decomposition will produce four subbands due to the decomposition of both  $a^1[N/2]$  and  $d^1[N/2]$  using the same set of filters. These subbands are  $aa^2[N/4]$ ,  $ad^2[N/4]$ ,  $da^2[N/4]$  and  $dd^2[N/4]$  as follows [2,13]:-

$$aa^2[n] = \sum_{k=0}^{\frac{N-1}{2}} g(k) a^1(n-k) \quad (3)$$

$$ad^2[n] = \sum_{k=0}^{\frac{N-1}{2}} h(k) a^1(n-k) \quad (4)$$

$$da^2[n] = \sum_{k=0}^{\frac{N-1}{2}} g(k) d^1(n-k) \quad (5)$$

$$dd^2[n] = \sum_{k=0}^{\frac{N-1}{2}} h(k) d^1(n-k) \quad (6)$$

A higher level of decomposition can be produced in the same procedure above.

The main advantage of WPT over continuous and discrete wavelet transform is better, more accurate and more detailed representation of the decomposed signals [13]. Also, wavelet packet basis functions are localized in time offering better signal

approximation and decomposition. These basis functions are generated from one base function at scale  $s$ , dilation  $a$  and translation  $b$  as follows [13]:

$$w_{s,a,b}(n) = 2^{j/2} W_a(2^{-j}(n-b)) \quad (7)$$

where  $W_a(n)$  is the wavelet function coefficient matrix. In WPT, a discrete signal  $f[n]$  is represented as a sum of orthogonal wavelet basis functions  $w_{s,a,b}(n)$  as follows:

$$f[n] = \sum_s \sum_a \sum_b w_{s,a,b}[n] W_a[n] \quad (8)$$

The implementation procedure of the WPT for two levels is shown in the decomposition tree of Fig.1.

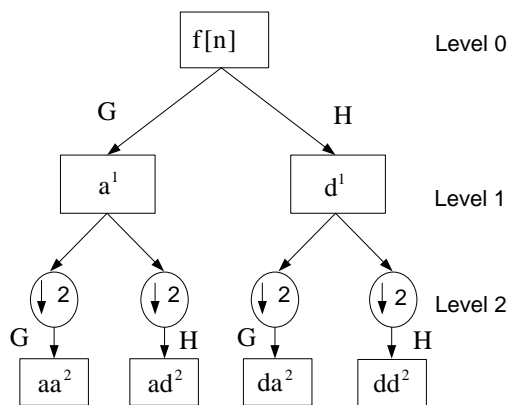

Fig.1 Two levels of decomposition by WPT

### 3- Source Disturbances Detection Using WPT Coefficients

The source power quality comprises various kinds of disturbances in the supply voltage and frequency. In all cases, the signal waveforms are generated from computer using Matlab code. The basic frequency is 50Hz and the basic voltage magnitude is 220V rms which is normalized. The sampling frequency is 12.5 kHz. Daubechies 4 (db4) is used as a mother wavelet function. The Matlab, wavelet toolbox functions [14] are used to

decompose the original signal into low and high frequency coefficients.

#### 3-1 Source Voltage Disturbance Analysis

- **Voltage Sag:** This problem occurs due to a fault switching of heavy load or starting of large motors. The amplitude of the voltage drops by 10 to 90 percent of the rated value. Figure (2-a) shows the normalized pure signal and Fig.(2-b) shows a normalized signal for 50% sag in the voltage waveform during three cycles.

- **Voltage Swell:** If a normal voltage increases by 10 to 90 percent, then it is known as a voltage swell. Figure (2-c) shows a normalized 50% swell in the voltage waveform during three cycles.

- **Voltage Interruption:** It means that the voltage is lost momentarily on a power system. Such disturbance describes a drop of 90 to 100 percent of the rated system voltage lasting for 0.5 cycle to 1 min. Figure (2-d) shows a normalized 100% momentary interruption lasting for 60ms.

- **Spike Voltage Oscillations:** The voltage disturbance is called oscillatory if it lasts for a time duration shorter than sags or swells. It can also be classified as impulsive, notched or spike. Figure (2-e) shows a normalized voltage signal with a spike for 10ms in two cycles.

- **Voltage Harmonics:** If the signal contains harmonics like 3<sup>rd</sup>, 5<sup>th</sup>, etc., then this source is called a voltage harmonic source. Figure (2-f) shows a normalized pure voltage with the 5<sup>th</sup> harmonic in 3 cycles.

The Shannon entropy-based criteria is used to calculate the energy of the signal coefficients at each level of decomposition of low and high frequency as follows [14]:-

$$E = -\sum_i f_i^2 \log(f_i^2) \quad (9)$$

where  $E$  is the Shannon entropy and  $f$  is the analyzed signal. The absolute entropy of the distorted function at each level is

compared with the associated pure function as follows:-

$$|\Delta E^j| = |E^j| - |E^p| \quad (10)$$

where  $j$  denotes the number of level of resolution of the WPT and  $|\Delta E|$  is the

difference in entropy values between the distorted and the pure (p) signal. Table 1 presents the feature vectors of the equations 9 and 10 which gives the difference in entropy values for  $|\Delta E_{ad}^j|$ ,  $j = 1, 2, \dots, 6$ ,  $|\Delta E_{aa}^6|$  and  $|\Delta E_{dd}^2|$ .

Table 1 feature vectors of equations 9 and 10 for a disturbances in source signal

signal type	$ \Delta E_{ad}^1 $	$ \Delta E_{ad}^2 $	$ \Delta E_{ad}^3 $	$ \Delta E_{ad}^4 $	$ \Delta E_{ad}^5 $	$ \Delta E_{ad}^6 $	$ \Delta E_{aa}^6 $	$ \Delta E_{dd}^2 $
sag	4.1898	84.3979	63.593	30.7842	18.1678	11.6745	17.6536	5.5704
swell	30.4983	975.8641	1317.96	1673.29	782.501	1690.14	46.0539	49.108
interrupt	35.8119	965.3641	1332.66	1425.39	658.347	1368.64	30.8835	39.997
spike	47.3461	1223.9751	1643.76	1794.23	801.653	1520.77	61.2357	57.815
harmonic	44.2619	1159.2641	1580.56	1520.39	702.335	57.8415	49.6709	45.527

From Table 1, it can be seen that the pattern of feature vectors for different voltage disturbance events are able differentiable effectively between themselves. Level two,  $dd^2$ , details has a significant difference in energy of distorted and healthy signals. The high frequency details  $dd^2$  vanished at levels bigger than two. Therefore, it can be considered as an extraction features to design a proposed algorithm for diagnosis of different disturbances occurred in power source voltage signal. The details  $dd^2$  for each voltage disturbance signal are drawn in Fig.3 (a-f) as a function of sample number.

### 3-2 Source Frequency Disturbances Analysis

The basic frequency considered in this analysis is 50Hz. Any disturbance in the supply frequency will affect the connected loads. The source frequency may change due to momentary change in prime mover speed or a disturbance in the solid state switching power supply. Figure 4 reflects the  $\pm 40\%$  disturbance in the supply frequency for 60ms. The feature vectors of the equations 9 and 10 which give the difference in entropy values for  $|\Delta E_{ad}^j|$ ,  $j = 1, 2, \dots, 6$ ,  $|\Delta E_{aa}^6|$  and  $|\Delta E_{dd}^2|$  are given in Table 2. The details  $dd^2$  for the mentioned disturbances are shown in Fig.5 which also can be considered as extraction features to design the same algorithm for diagnosis of disturbances in supply frequency.

Table 2 feature vectors of equation 9 and 10 for a disturbances in source frequency

$\Delta f$	$ \Delta E_{ad}^1 $	$ \Delta E_{ad}^2 $	$ \Delta E_{ad}^3 $	$ \Delta E_{ad}^4 $	$ \Delta E_{ad}^5 $	$ \Delta E_{ad}^6 $	$ \Delta E_{aa}^6 $	$ \Delta E_{dd}^2 $
$\pm 0.2\%$	1777.74	582.164	592.005	153.537	65.0258	22.5494	24.8161	1096.81
$\pm 0.4\%$	9043.34	3201.76	3150.26	924.197	409.210	156.843	181.964	5685.91
$\pm 2\%$	254670	105799	101540	328226	15700.4	6633.92	7548.45	165627
$\pm 40\%$	106670	25968	22911	10394	2421.2	327.33	1972.9	63302

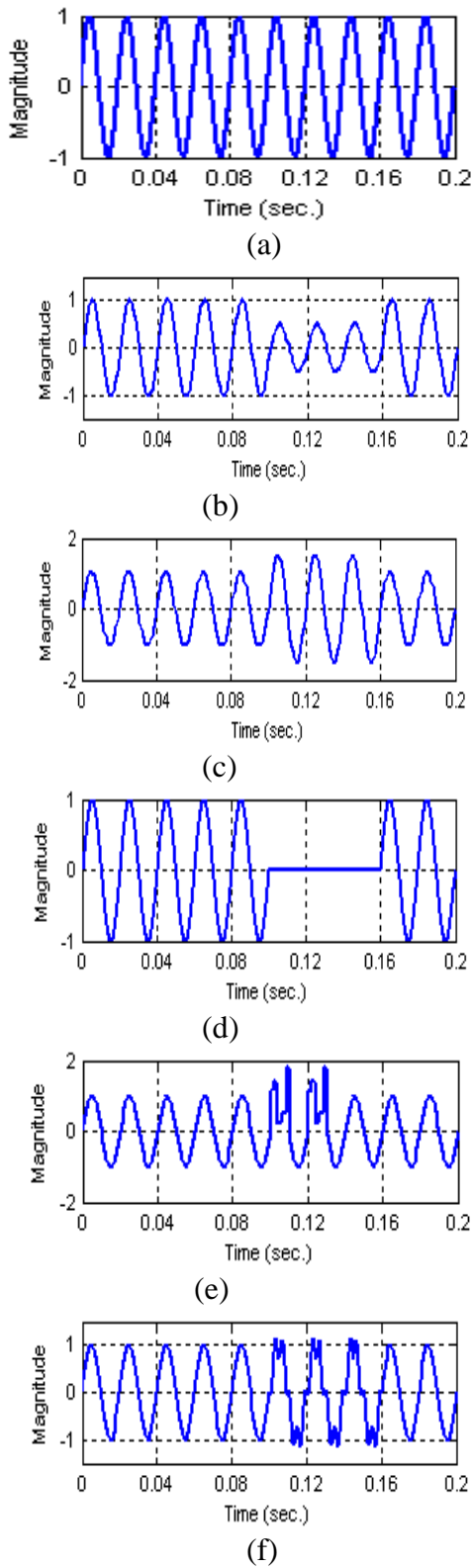

Fig.2 Voltage signals (a) healthy (b) sag (c) swell (d) interrupt (e) spike (f) harmonics.

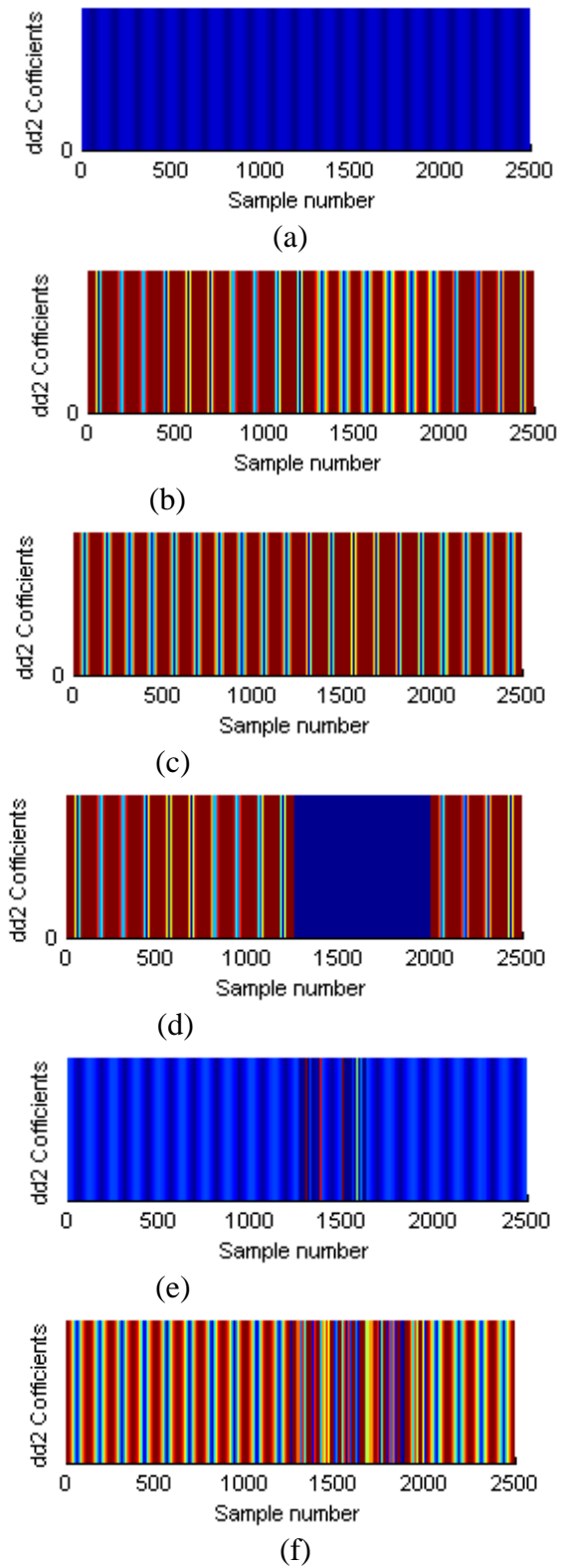

Fig.3 Second level high frequency details  $dd^2$  for voltage signals (a) healthy (b) sag (c) swell (d) interrupt (e) spike (f) harmonics.

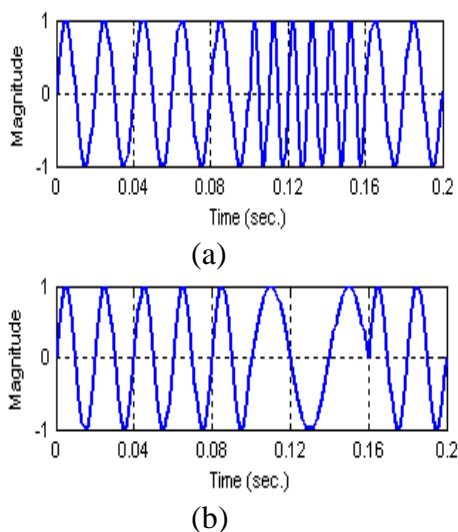

Fig.4 Voltage signal with disturbance in frequency  
(a) increase by 40% (b) decrease by 40%.

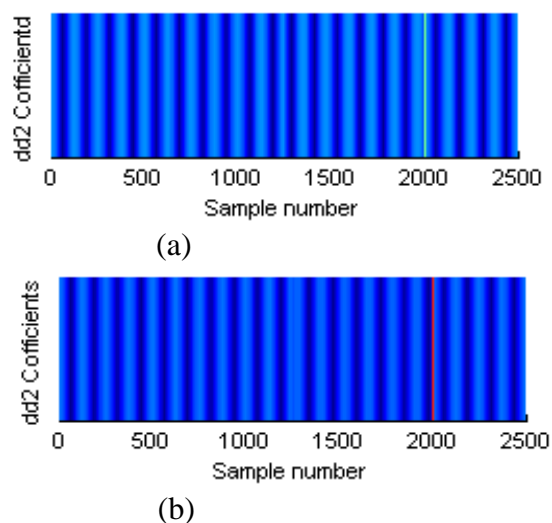

Fig. 5 Second level high frequency details  $dd^2$  for  
a disturbance in frequency (a) increase by 40%  
(b) decrease by 40%.

#### 4- Proposed WPT Disturbances Detector

In order to detect and monitor any disturbance, it is necessary to build the extraction features. A successful features involve the identification of abnormal conditions by the mathematical modeling of the complete system or the analysis of fault signatures resulting from different transient disturbances. A signature analysis method is used for the present proposed WPT disturbance detector. The signal is decomposed up to second level of resolution by WPT using the selection mother wavelet "db4". The proposed method looks at the second level high frequency details  $dd^2$  coefficients in different types of disturbances. The second levels  $dd^2$  coefficients are given in Figs.3 and 5. The simulated results of these figures are used to analyze the signatures of various disturbances in voltage and frequency. In the healthy signal, the second level  $dd^2$  coefficients are around zero while the associated  $dd^2$  coefficients for any type of disturbances will include a threshold value represented by Shannon entropy in the last column in Tables 1 and 2 for disturbances in voltage signal and

supply frequency respectively. These values can be used as extraction features for the proposed WPT disturbances detector. The proposed WPT algorithm is given in the flowchart of Fig.6.

Firstly, the three-phase voltage signals are read and sampled. The sampled signals are passed through high pass filter to find the first level  $d^1V_a$ ,  $d^1V_b$  and  $d^1V_c$ . The outputs are downsampled by two and then passed through another high pass filter to construct the details  $dd^2V_a$ ,  $dd^2V_b$  and  $dd^2V_c$ . If the absolute value of  $dd^2$  coefficients for each voltage signal is in the range of voltage disturbance threshold ( $V_{thresh}$ ), then it detect a signal for a disturbance in the voltage signal. And if the absolute value of  $dd^2$  coefficients for each voltage signal is in the range of frequency disturbance threshold ( $f_{thresh}$ ), then it detect a signal for a disturbance in the supply frequency. The threshold is selected by the maximum absolute value of the WPT coefficients of the second level of decomposition during any disturbance condition.

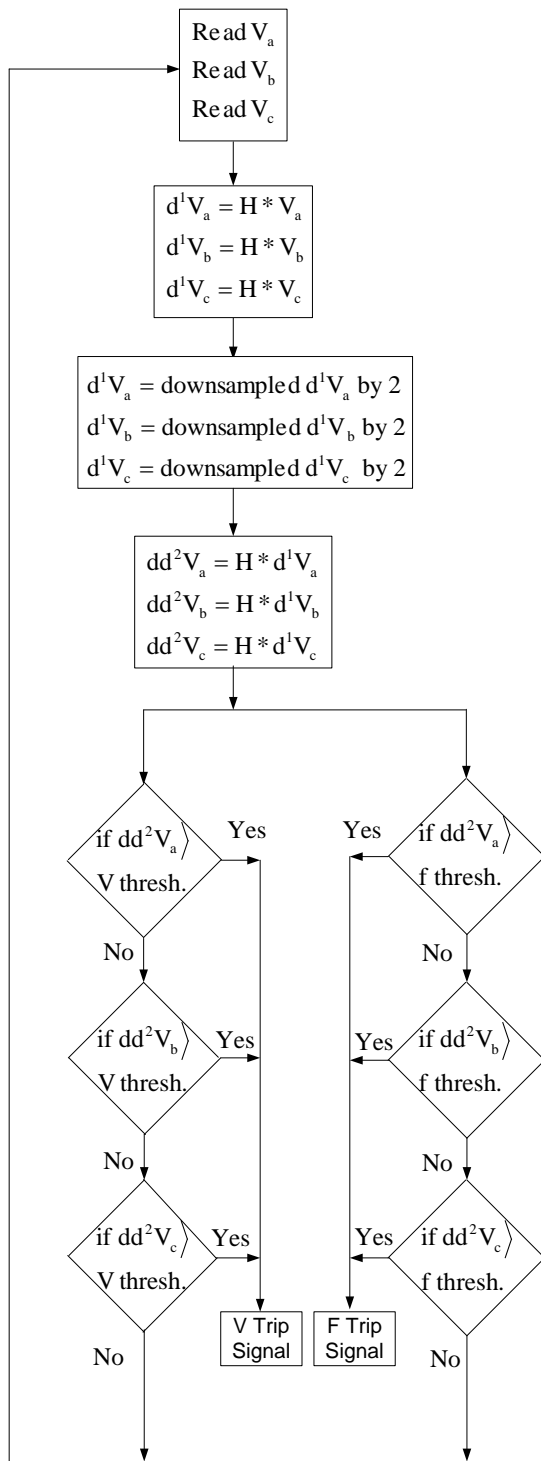

Fig.6 Flowchart for a WPT disturbances detector.

### 5- Testing of the Proposed WPT Algorithm

The simulated setup of the disturbances detection and monitoring incorporating the protection circuit for a connected load is shown in Fig.7. The three-phase signal is considered as input to the WPT algorithm while the control signal is its output. The control signal can be used for controlling a triac switch to isolate the load from the supply if an undesirable disturbance is occurred..

Figures 8(a)-8(d) show the detector response and phase (a) voltage signal for two kinds of disturbances in a voltage signal, Fig.8(a)-8(b), (sag and spike) and two kinds of frequency disturbances, Fig.8(c)-8(d), ( increase and decrease). In each figure, the disturbances start at 0.1 and 0.3 sec. respectively and lasted for 60msec. The WPT-based detection algorithm using the second level high frequency coefficients  $dd^2$  directly identified any disturbance promptly and properly and initiated a trip signal within less one cycle of the disturbance occurrence. It is mentioned here that the trip signal is not used to isolate the load from the supply. The decision is left to the designer and can be controlled by the algorithm.

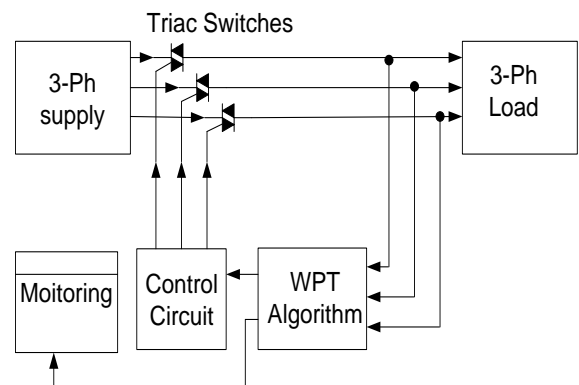

Fig.7 Simulated setup for disturbances detection and monitoring.

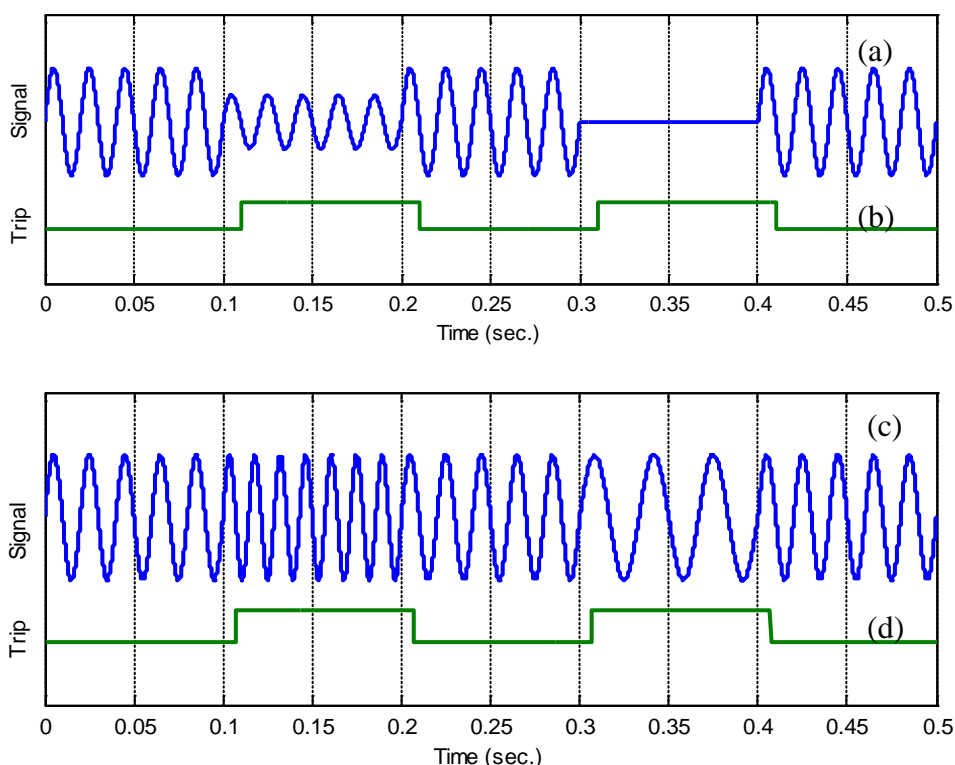

Fig.8 (a) A disturbances in the voltage signal, (b) the detected trip signal for (a), (c) a disturbances in supply frequency, (d) the detected trip signal for (c).

## 6- Conclusion

A diagnosing method for power quality disturbances based on WPT is presented. Several power quality problems have been analyzed. The Shannon entropy of the high and low frequency coefficients are calculated for different levels of resolution and a decision to use the second level high frequency details  $dd^2$  is considered as a construction features to design a proposed WPT algorithm detector. The proposed disturbances detector showed successfully and fast response for diagnosing the distorted signals and it provides an interesting and significant tool in detecting power quality problem.

## References:

- 1- L. Lin, N. Huang, and W. Huang, "Review of Power Quality Signal Compression Based on Wavelet Theory" IEEE Conference on Test and Measurement, PP235-238, 2009.
- 2- M. A. S. K. Khan, T. S. Radwan and M. A. Rahman, "Real Time Implementation of Wavelet Packet Transform Based Diagnosis and Protection of Three-Phase Induction Motors" IEEE Trans. Energy Conversion, Vol. 22, No. 3, Sep., 2007.
- 3- P. K. Dash. B. K. Panigrahi and G. Panda, "Power Quality Analysis Using S-Transform" IEEE Trans. Power Delivery, Vol. 18, No. 2, PP. 406-411, 2003.
- 4- L. Shangwel and S. Yaming, " Study on the Classification Method of Power Disturbances Based on the Combination of S Transform and SVM Multi-Class Classifier with Binary Tree", 3<sup>rd</sup> International Conference on Electric Utility Deregulation and Restructuring and Power Technologies, PP. 2275-2280, 2008.



- 5- Y. Jia, Z. Y. He and T. L. Zang, "S-Transform Based Power Quality Indices for Transient Disturbances", IEEE conference on Power and Energy Engineering, Asia-Pacific, PP. 1-4, 2010.
- 6- N. Huang, W. Huang, L. Lin and J. Qi, "Review of Power-Quality Disturbance Recognition Using S-transform" IEEE IITA International Conference on Control, Automation and Systems Engineering, PP. 438-441, 2009.
- 7- Z. Wen-yuan, "The Detection of Power Quality Hybrid Disturbance Based on S Transform" IEEE Conference on Power and Energy Engineering, Asia-Pacific, PP. 1-4, 2010.
- 8- W. Wen-jun, F. Jian-hua and L. Wan-shan, "The Application of WPT in Compress Power Quality Disturbance" IEEE Conference on Control and Decision, Chinese, PP. 384-387, 2010.
- 9- L. L. Lai, W. L. Chan, C. T. Tse and A. T. P So, "Real-time Frequency and Harmonic Evaluation Using Artificial Neural Network", IEEE Trans. On Power Delivery, Vol. 14, No. 1, PP. 52-59, 1999.
- 10- W. L. Chan, A. T. P. So and L. L. Lai, "Harmonics Load Signature Recognition by Wavelet Transform", International Conference on Electric Utility Deregulation Restructuring and Power Technologies DRPT2000, IEEE, PP. 666-671, 2000.
- 11- A. Elmitwaly, S. Farghal, M. Kandil, S. Abdelkader, and M. Elkateb, "Proposed Wavelet-NeuroFuzzy Combined System for Power Quality Violations Detection and Diagnosis," Proc. Inst. Elect. Eng., Gen. Trans. Dist., Vol. 148, No. 1, PP. 15-20, 2001.
- 12- N. C. F. Tse., "Practical Application of Wavelet to Power Quality Analysis", IEEE Power Engineering Society General Meeting, 2006.
- 13- G. Stang and T. Nguyen, "Wavelet and Filter Banks" Wellesley, MA: Wellesley-Cambridge, 1996.
- 14- Math Works, Matlab, "Wavelet Tool Box, Ver. 2.