

## **EFFECT OF ELECTROLYTE CONCENTRATION ON BUBBLE SIZE AND GAS-LIQUID INTERFACIAL AREA IN BUBBLE COLUMN**

**Farah T. Jassem**  
**Department of Chemical Engineering**  
**University of Technology**

### **ABSTRACT**

The optimum conditions of bubble column would be the ones that enhance mass transfer and this is accomplished by maximizing gas-liquid interfacial area. In the present work the effect of electrolyte concentration (aqueous solution of sodium chloride NaCl 0.005-0.015 gm/cm<sup>3</sup>) on bubble size, gas-liquid interfacial area and gas holdup at various superficial gas velocities (0.35-0.312 m/s) in bubble column was studied. A series of experiments were also performed for air – distilled water system at various superficial gas velocities. The results for the two systems were compared and show a significant difference on gas-liquid interfacial area, bubble size and gas holdup. Digital camera for bubble size measurements was used and the fractional gas holdup was estimated using bed expansion. Correlation based on dimensionless groups for the prediction of bubble size, gas-liquid interfacial area and gas holdup is suggested. An agreement with available data was found

**KEYWORDS**

Bubble column, Electrolyte solutions, design parameters, Gas liquid interfacial area

**NOMENCLATURE**

Symbol	Definition	Unit
a	Gas-liquid interfacial area	m <sup>-1</sup>
B <sub>o</sub>	Bond number $\frac{\rho_L D_C^2 g}{\sigma}$	( - )
C <sub>o</sub>	Distribution coefficient in equation ( 2 )	( - )
d <sub>i</sub>	Bubble diameter class i	m
d <sub>o</sub>	Sauter mean bubble diameter	m
D <sub>c</sub>	Column diameter	m
E <sub>g</sub>	Gas holdup	( - )
Fr	Froude number $\frac{U_g}{\sqrt{g D_C}}$	( - )
Ga	Gallilei number $\frac{\rho_L^2 D_C^3 g}{\mu_L^2}$	( - )
g	Acceleration of gravity	m/s <sup>2</sup>
H	Clear liquid height	m
H <sub>f</sub>	Aerated liquid height	m
n <sub>i</sub>	Number of bubble of diameter class i	( - )
Re	Reynolds number $\frac{\rho_L U_g D_C}{\mu_L}$	( - )
U <sub>br</sub>	Bubble rise velocity	m/s
U <sub>g</sub>	Superficial gas velocity	m/s

**Continued**

Symbol	Definition	Unit
<b>Greek Letters</b>		
$\mu_L$	Liquid viscosity	Pa.s
$\rho_L$	Liquid density	kg/m <sup>3</sup>
$\sigma$	Surface tension	N/m

**INTRODUCTION**

Facial construction and low costs make bubble columns highly attractive gas-liquid contactors. Their use as absorbers, fermenters, catalytic reactor, coal liquefiers ... etc., is widespread and extensive .In all these processes gas holdup and bubble size are important design parameters for scale up of bubble column reactors, since they define the gas-liquid interfacial area available for mass transfer (Parasu et al 2000<sup>[1]</sup>, Paras et al 2004<sup>[2]</sup>).The hydrodynamics of bubble column depends upon the regime of operation viz. homogeneous " bubbly flow" regime encountered at low gas velocities and characterized by a narrow bubble size distribution and radially uniform gas holdup , and heterogeneous "churn turbulent "flow regime observed at higher gas velocities and characterized by the appearance of large bubbles, formed by coalescence of small bubbles and bearing a higher rise velocity hence leading to relatively lower gas holdup values, gas-liquid interfacial area and mass transfer (Zahradnik et al 1997<sup>[3]</sup>, Camarasa et al 1999<sup>[4]</sup>, Joshi et al 2002<sup>[5]</sup> and Paras et al

2004<sup>[2]</sup>). It is important to promoting breakage and demoting bubble coalescence. This can be achieved by aqueous solution of electrolyte (Jamialahmadi et al 1990<sup>[6]</sup>, Zahradnik et al 1995<sup>[7]</sup>). The presence of electrolytes decreases the coalescence rate therefore increases the gas holdup.

Marrucci and Nicodeno 1967<sup>[10]</sup> concluded from their investigation that the ease of bubble coalescence depends on whether cations or anions are adsorbed at the surface of the bubbles.

Akita and Yoshida 1974<sup>[8]</sup>, Akita 1989<sup>[9]</sup> suggested that higher gas holdup and gas-liquid interfacial area in electrolyte solutions is due to the electrostatic potential at the gas-liquid interface.

Prince and Balnch 1990<sup>[11]</sup>, Graig et al 1993<sup>[12]</sup> and Zahradnik et al 1995<sup>[7]</sup> studied the effect of electrolytes on bubble coalescence and gas holdup.

Zahradnik et al 1999<sup>[13]</sup> show the effect of electrolyte addition on bubble coalescence in sacchorose solution.

In the present work, the effect of electrolyte concentration (NaCl on bubble size, bubble rise velocity, gas-liquid interfacial area and gas holdup for various superficial gas velocities was studied.

## EXPERIMENTAL WORK

### Experimental apparatus

Experiments were carried out in a glass (QVF) cylindrical bubble column of 15 cm i.d.\* 1.6 m height .Schematic diagram of experimental setup is shown in figure (1). Perforated plate sparger was used as gas distributor (104 hole of 1 mm diameter) and placed between the column and distributor chamber which having a drain at the bottom and gas inlet at the side. Gas (air) flow rate was measured by using two calibrated rotameters for superficial gas velocities from 0.083 m/s to 0.13 m/s to achieve homogeneous flow regime.

Two systems were used in experiments, namely, air-distilled water and air-electrolyte solution (aqueous solution of sodium chloride NaCl) in a wide range of NaCl concentration in distilled water from 0.005 to 0.015 gm/cm<sup>3</sup> for low concentration and from 0.02 to 0.056 gm/cm<sup>3</sup> for high concentration. All experiments were performed at ambient temperature and atmospheric pressure.

### Measurement

#### - Gas Holdup and Bubble Rise Velocity.

The fractional gas holdup was estimated from bed expansion

$$E_g = \frac{H_F - H}{H_F} \dots\dots\dots (1)$$

Bubble rise velocity in homogenous flow regime can be estimated from drift flux model of Zuber and Findlay 1965<sup>[15]</sup> as:-

$$\frac{U_g}{E_g} = C_o * U_g + U_{br} \dots\dots\dots (2)$$

Where the experimental data  $U_g/E_g$  are plotted against  $U_g$ , then the  $U_{br}$  can be obtained from the intercept of  $U_g/E_g$  axis.

**- Sauter mean bubble diameter.**

The bubble size was measured by photographic method. Digital camera (Type Olympus model 4000-2000n of 4.0 mega pixel) was used in the experimental work. The camera was connected online to the computer to measure the bubble size. Images projected on the screen were enlarged about 5.5 times the actual size. Bubble images were obtained at different heights from bottom to top.

The bubble size was defined by sauter mean bubble diameter as follows:-

$$d_o = \frac{\sum nidi^3}{\sum nidi^2} \dots\dots\dots (3)$$

**- Gas-Liquid Interfacial Area.**

Gas-liquid interfacial area can be calculated from gas holdup and sauter mean bubble diameter; as (Alves et al 2003<sup>(14)</sup>, Akita and Yoshida 1974<sup>(9)</sup>):-

$$a = \frac{6 * Eg}{d_o} \dots\dots\dots (4)$$

## RESULTS AND DISCUSSION

### Influence of Superficial Gas Velocity

Figures (2 to 4) show the effect of superficial gas velocity on gas-liquid interfacial area and gas holdup at different electrolyte concentration and water. It can be seen that the gas-liquid interfacial area increases with increasing superficial gas velocity up to 0.117 m/s for high electrolyte concentrations. This is attributed to the fact that the rate of breakup of bubbles increased. In addition, higher superficial gas velocity gives smaller bubbles as shown in figures (5 and 6). The smaller bubble of lower rising velocity this leads to form large residence time and consequently higher gas hold-up and gas – liquid interfacial area. Further increasing of superficial gas velocity has an adverse effect on gas-liquid interfacial area. This is due to the formation of large bubble which leads to lower gas holdup.

In air-water system increasing superficial gas velocity gives smaller bubbles which leads to increasing gas-liquid interfacial area and gas holdup, but at lower values than in that for air-electrolyte solutions as shown in figures (2 and 5). These results are in agreement with the results of Paras et al 2003<sup>(2)</sup> and Jamialahmadi and Muller 1990<sup>[6]</sup>.

### **Influence of Electrolyte Concentration**

Figures (7 and 8) illustrate the influence of low electrolyte concentrations on gas-liquid interfacial area and gas holdup at different superficial gas velocities. It can be seen that the gas-liquid interfacial area increases with increasing NaCl concentration. It is obvious that the size of air bubbles generated in electrolyte solutions of low concentrations (0.005 to 0.015 gm/cm<sup>3</sup>) is reduced slightly as shown in figure (9). From this observation it may be concluded that the higher gas-liquid interfacial area and gas holdup in electrolyte solutions is not caused by the reduction of bubble size at the gas distributor plate. The surface tension at the interface between bubble and electrolyte solution is higher than that for pure water, due to the presence of dissolved ions. However because of the higher attractive forces between water molecules and electrolyte ions as compared to those between water molecules, these ions will be quickly removed from the interface into the bulk of the solution. Therefore the actual surface tension should be lower than the initial surface tension, approaching that for pure water for low electrolyte concentration. Ionic forces between ions and water molecules make the solution more cohesive (Jamialahmadi and Muller 1990). The reduction in bubble rise velocities with increasing NaCl concentration is shown in table (1), which was obtained from figure (10). The experimental data ( $U_g/E_g$ ) plotted against  $U_{br}$  bubble rise velocity ( $U_{rb}$ ) can be obtained from  $U_g/E_g$



-axis intercept as shown in figure (10). These results are in agreement with the result of Jamialahmadi and Muller 1990<sup>[6]</sup> and Zahradnik et al 1999<sup>[13]</sup>.

Figures (11 and 12) show the effect of high electrolyte concentrations (0.02 to 0.056 gm/cm<sup>3</sup>) on gas-liquid interfacial area and gas holdup at different superficial gas velocities. It can be seen that by increasing electrolyte concentrations, gas-liquid interfacial area and gas holdup increased. The reason is that there is remarkable change in liquid properties such as increase of surface tension, which favor small bubble formation with lower bubble rise velocity by promoting breakage and demoting coalescence which leads for increasing gas holdup as shown in figure (13) and table (2). The experimental data ( $U_g/E_g$ ) plotted against  $U_g$  as shown in figure (14), bubble rise velocity can be obtained from  $U_g/E_g$ -axis intercept. These results are in agreement with the result of Zahradnik et al 1995<sup>[7]</sup>.

### **Correlation**

From the experimental results a correlation was formulated that permit the prediction of gas-liquid interfacial area, gas holdup and sauter mean bubble diameter with the variables that greatly affects the bubble column operation. Dimensional analysis was performed. The following correlations were obtained and found to be in a good agreement with experimental data:-

**For Low Electrolyte Concentration. (0.001-0.01)**

$$\frac{E_g}{(1-E_g)^{3.673}} = 2.7863(Bo)^{-0.1573}(Ga)^{-0.3846}(Fr)^{0.0413} \dots\dots\dots(5)$$

Correlation coefficient = 0.995

$$\frac{d_o}{D_c} = 1.298(Bo)^{-0.371}(Re)^{-0.14}(Fr)^{-0.586}\left(\frac{H}{D_c}\right)^{2.56} \dots\dots\dots(6)$$

Correlation coefficient = 0.902

Combining equation (3), (5) and (6), gas-liquid interfacial area correlation can be obtained:

$$aD_c = 12.879(Bo)^{0.2137}(Ga)^{-0.2446}(Fr)^{0.627}\left(\frac{H}{D_c}\right)^{-2.56} (E_L)^{3.673} \dots\dots\dots(7)$$

**For High Electrolyte Concentration. (0.01-0.015)**

$$\frac{E_g}{(1-E_g)^{3.673}} = 5.413(Bo)^{0.0624}(Ga)^{0.1015}(Fr)^{0.0698} \dots\dots\dots (8)$$

Correlation coefficient = 0.92

$$\frac{d_o}{D_c} = 1.7425(Bo)^{-0.1}(Ga)^{0.1}(Fr)^{-0.0285}\left(\frac{H}{D_c}\right)^{0.738} \dots\dots\dots(9)$$

Correlation coefficient = 0.89

Combining equation (3), (8) and (9), gas-liquid interfacial area correlation can be obtained:

$$aD_c = 18.638(Bo)^{0.162}(Ga)^{0.0015}(Fr)^{0.0983}\left(\frac{H}{D_c}\right)^{-0.738} (E_L)^{3.673} \dots\dots\dots 10$$

### Concluding remarks

The following points are concluded from the present work:-

- \* Gas-liquid interfacial area increases with increasing superficial gas velocity up to 0.117 m/s only for high electrolyte concentration. This is also for gas holdup while sauter mean bubble diameter decreased. Further increasing of superficial gas velocity for more than 0.117 m/s for high electrolyte concentration has an adverse effect on gas-liquid interfacial area.
- \* In air-distilled water system, gas-liquid interfacial area, gas holdup and sauter mean bubble diameter are lower than that in air electrolyte solution system.
- \* Low electrolyte concentration has slight effect on the surface tension of the solution. However the ionic force in the liquid bulk reduces the bubble rise velocity and reduces bubble coalescence. As a result, gas holdup and gas-liquid interfacial area increased.
- \* In higher electrolyte concentration the surface tension has remarkable effect on gas-liquid interfacial area gas holdup and bubble size.

### REFERENCES

1. Parasu Veera, U. and Joshi, J.B., Trans IChemE, vol.78, Part A, 425-434, April 2000.
2. Paras, S.V., Dalakoglou, G.K. and Mouza, A.A., Chem.Eng.Sci, vol.60, 1465-1475, 2004.

3. Zahradnik, J., Fialova, M., Ruzicka, M., Drahos, J., Kastanet, F. and Thomas, N.H., Chem.Eng.Sci, 52, 3811-3826, 1997.
4. Camarasa, E., Vial, C., Poncin, S., Wild, G., Midoux, N. and Bouilliard, J., Chem.Eng.Proce., 38, 329-344, 1999.
5. Joshi, J.B., Vitankar, V.S., Kulkarni, A.A., Dhotre, M.T. and Ekambara, K., Chem.Eng.Sci, 57, 3157-3183, 2002.
6. Jamialahmadi, M. and Muller, S.H., Chem.Eng.Res. and Design, vol.68, A2, 202-204, 1990.
7. Zahradnik, J., Fialova, M., Kastanet, F., Green, K. and Thomas, N.H., Trans IChemE, vol.73, 341-346, 1995.
8. Akita, K. and Yoshida, F., Ind.Eng.Chem.Process Des.Dev., 1, 84-91, 1974.
9. Akita, K., Int.Chem.Eng. , 29, 127-135, 1989.
10. Marrucci, G. and Nicodeno, L., Chem.Eng.Sci, 22, 1257-1265, 1967.
11. Prince, M and Blanch, H., AIChE.Journal, 10, 1485-1499, 1990.
12. Graig, V., Nigham, B. and Pashley, R., Letter Nasture, vol.364, 317-319, 1993.
13. Zahradnik, J., Kuncova, G. and Fialova, M., Chem.Eng.Sci, 54, 2401-2408, 1999.
14. Alves, S.S., Orvalho, S.C.P., Rodrigues, J.M.L, and Vasconcedos, J.M.T., Chem.Eng.Sci, 58, 1431-1440, 2003.

15. Zuber, N. and Findlay, J.D., J. Heat Transfer Trans. ASME Ser.C, 87, 453-468, 1965.
16. Shah, Y.T., Kelkar, B.G., Godbole, S.P. and Dckwer, W.D., AIChE, 28, 353-379, 1982

**Table (1) Bubble Rise Velocity in  
Low Electrolyte Concentration.**

<b>NaCl Concentration (gm/cm<sup>3</sup>)</b>	<b>Bubble Rise Velocity (m/s)</b>
0.005	0.3508
0.007	0.344
0.01	0.336
0.012	0.321
0.015	0.312
<b>Distilled water</b>	0.445

**Table (2) Bubble Rise Velocity in  
high Electrolyte Concentration.**

<b>NaCl Concentration (gm/cm<sup>3</sup>)</b>	<b>Bubble Rise Velocity (m/s)</b>
0.02	0.2509
0.028	0.249
0.05	0.246
0.04	0.24
0.06	0.228

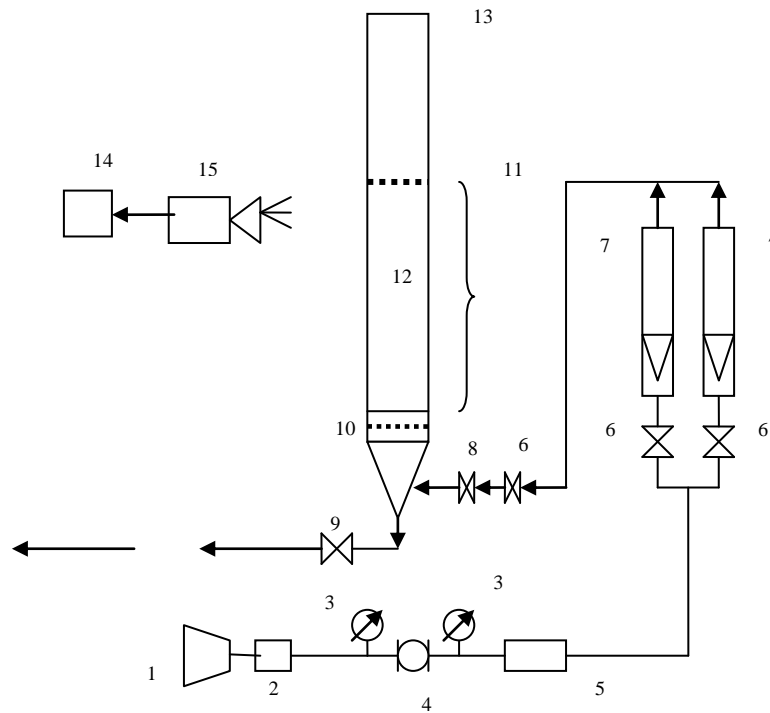

**a- Schematic diagram of experimental set up.**

- 1- Air Compressor
- 2- Surge tank
- 3- Pressure gauge
- 4- Needle valve
- 5- Dryer filter
- 6- On-off valve
- 7- Rotameter
- 8- Check valve
- 9- Discharge valve
- 10 – Gas distributor
- 11- Liquid level
- 12- Bubble column
- 14- computer
- 15- Digital camera.

**Figure. (1) a- Schematic diagram of experimental set up .**

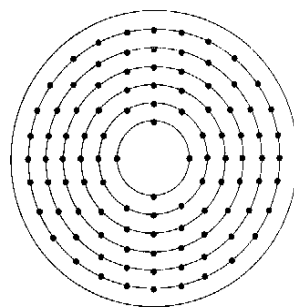

**Figure. (1) b- Gas distributor.**

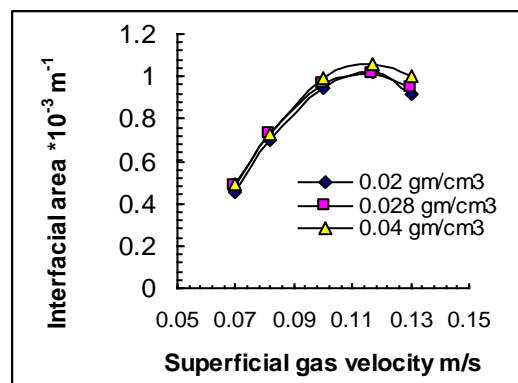
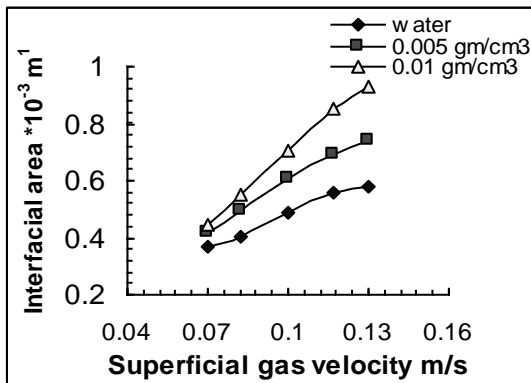

Fig.(2) Interfacial vs. area superficial gas velocity at different low electrolyte concentration and water.

Fig.(3) Interfacial vs. area superficial gas velocity at different high electrolyte concentration.

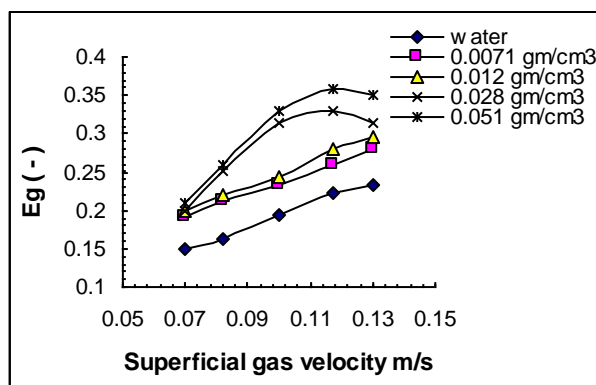
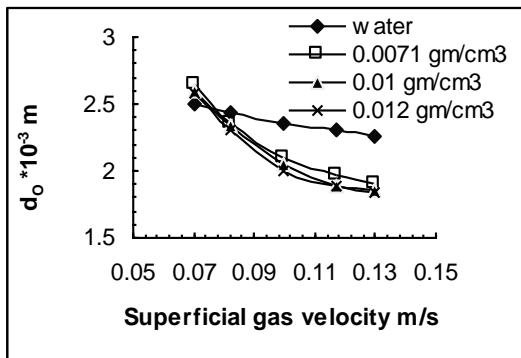
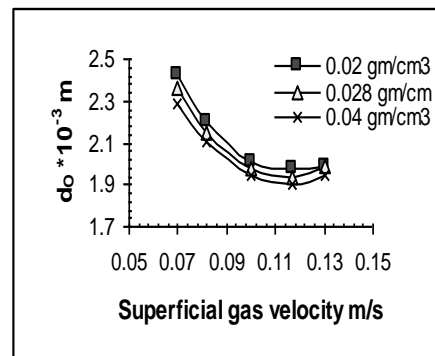

Fig.(4) Gas holdup vs. superficial gas velocity at different of electrolyte concentration and water.





**Fig(5) Sauter mean bubble diameter vs. superficial gas velocity at different low electrolyte concentration and water.**



**Fig(6) Sauter mean bubble diameter Superficial gas velocity vs. at different high electrolyte concentration.**

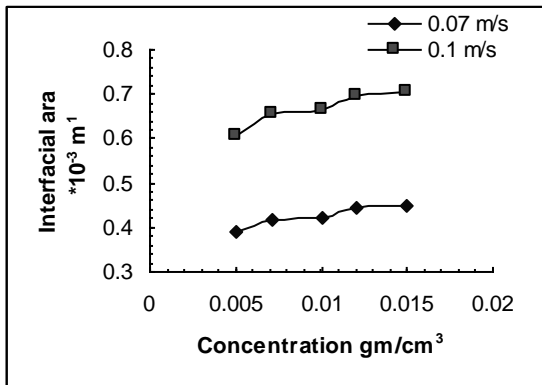

**Fig(7)Low electrolyte concentration vs. interfacial area at different superficial gas velocity.**

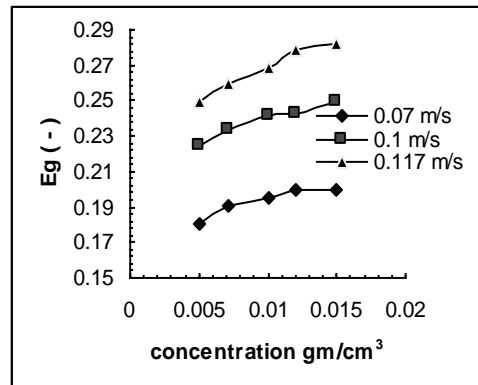

**Fig(8)Low electrolyte concentration vs. gas holdup at different superficial gas velocity.**

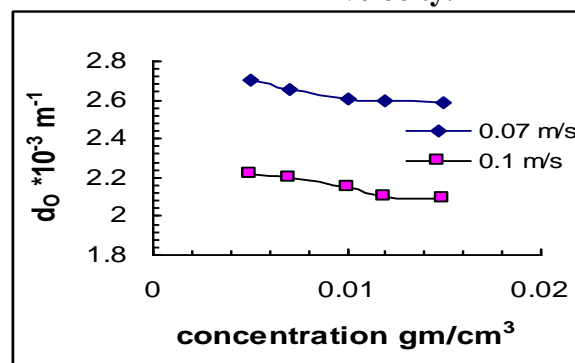

**Fig(9)Low electrolyte concentration vs. sauter mean bubble diameter at different superficial gas velocity.**

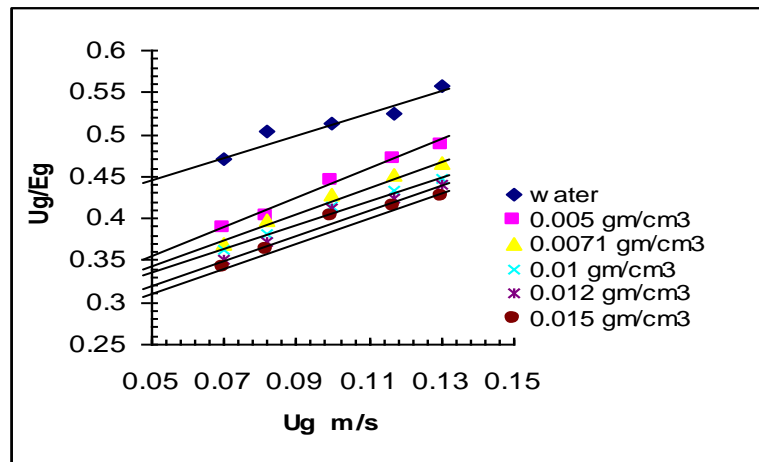
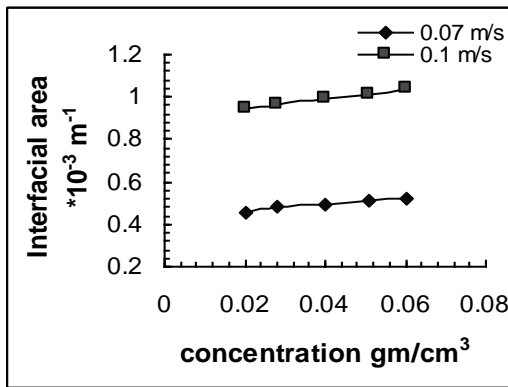
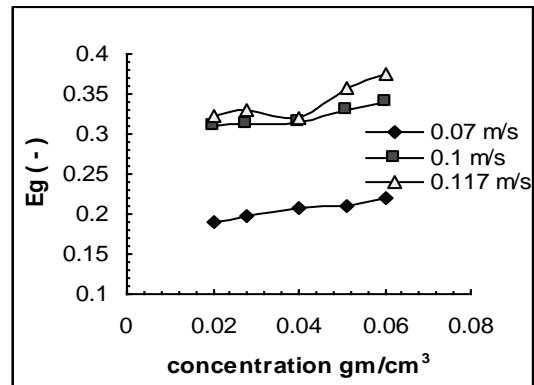

Fig.(10) Superficial gas velocity vs.  $U_g/E_g$  at different low electrolyte concentration and water.



Fig(11) High electrolyte concentration vs. interfacial area at different superficial gas velocity.



Fig(12) High electrolyte concentration vs. gas holdup at different superficial gas velocity.

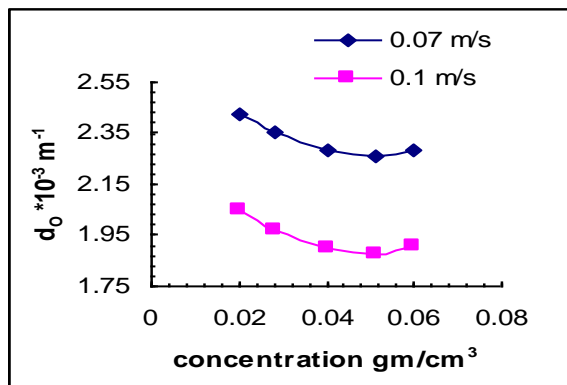

Fig(13) High electrolyte concentration vs. sauter mean bubble diameter at different superficial gas velocity.

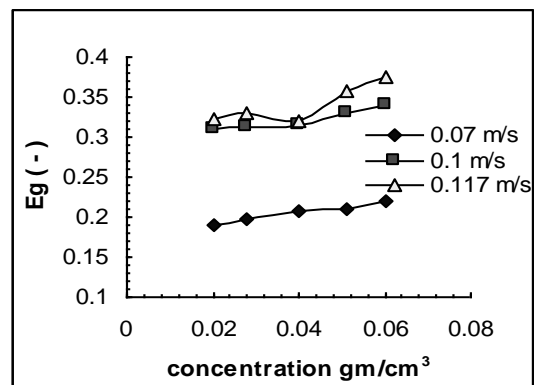

Fig.(14) Superficial gas velocity vs.  $U_g/E_g$  at different of high electrolyte concentration.

## تأثير تركيز المحاليل الألكتروليتية على حجم الفقاعة و المساحة البينية بين السائل و الغاز في عمود الفقاعات

فرح طالب جاسم

مدرس مساعد /قسم الهندسة الكيمياوية /الجامعة التكنولوجية

### الخلاصة

شاع استخدام الاعمده الفقاعية في الصناعات الكيماوية والبايوكيماويه وأفضل الظروف للاعمده الفقاعية هي زيادة معدل انتقال الكتلة وهذا يحدث عند زيادة مساحه التماس بين الغاز والسائل .

يتضمن البحث دراسة نظامي air-water و air-aqueous electrolyte solution لبيان تأثير المحلول الاليكتروليتي على مساحه التماس بين الغاز والسائل ، قطر الفقاعة و كميته الغاز المحتجز عند معدلات جريان مختلفة.

بينت النتائج العملية لنظام air – aqueous electrolyte solution تأثير واضح على مساحه التماس بين الغاز والسائل ، قطر الفقاعة و كميته الغاز المحتجز عند مقارنتها مع النتائج العملية لنظام air-water. استنادا إلى النتائج العملية ،تم إيجاد علاقة رياضية لكل من مساحه التماس بين الغاز والسائل a ، قطر الفقاعة  $d_0$  و كميته الغاز المحتجز Eg بطريقة Dimensional analysis وتم تحليل النتائج لهذه العلاقات لإيجاد درجة الخطأ أو مقدار دقة القياسات وأظهرت هذه العلاقات تطابقاً جيد مع النتائج العملية.

### الكلمات الدالة

عمود الفقاعات، المساحة البينية