

An Adaptive Fuzzy Inference System for 3-Phase Synchronous Generator Excitation Control

Fadhil A. Hassan*, Lina J. Rashad*, Fatma H. Faris*

Received on: 16/6/2010

Accepted on: 7/10/2010

Abstract

This paper proposes the excitation system control of three phase synchronous generator for improving the step response using an adaptive fuzzy controller. The dynamic model and simulation of 3-phase synchronous generator are proposed. The open loop voltage control responses under no-load and full-load conditions are proposed too. The PI closed loop controller of excitation system is illustrated as a conventional control method, which gives an acceptable operation behavior of synchronous generator terminal voltage. An adaptive fuzzy inference system is proposed in this paper as a close loop controller, which gives an ideal performance in both of no-load and full-load conditions as compared with PI controller to control the 3-phase synchronous generator excitation system. Simulation results show the effectiveness of the proposed fuzzy controller scheme Which gives in fuzzy controller; rise time= 0.3 sec., overshoot= 0%, settling time= 0.3 sec., and steady state error= 0%. Whereas, in PI controller; rise time= 0.55 sec., overshoot= 20%, settling time= 2.8 sec., and steady state error= 0%.

Keywords: Three Phase Synchronous Generator, Excitation System Control, PI Controller, Fuzzy Controller.

نظام الاستدلال الضبابي المكيف للسيطرة على إثارة المولد التزامني ثلاثي الأطوار

الخلاصة

يقدم هذا البحث السيطرة على نظام الأثارة المغناطيسية للمولد التزامني ثلاثي الأطوار باستخدام المسيطر الضبابي المكيف لتحسين الاستجابة لأشارة الخطوة. كما ويقدم النموذج الديناميكي والتمثيل الرياضي للمولد التزامني ثلاثي الاطوار. كما ويقدم أيضاً استجابة الحلقة المفتوحة للسيطرة على جهد المولد في ظروف اللاحمل والحمل الكامل. كما ويوضح البحث مسيطر الحلقة المغلقة التناسبي التكاملية كمسيطر تقليدي لنظام الأثارة، والذي قدم أداءً مرضياً لجهد الأخراج للمولد التزامني. كما ويقدم البحث نظام الاستدلال الضبابي المكيف كمسيطر للحلقة المغلقة للنظام، والذي أعطى أداءً مثالياً في السيطرة على نظام الأثارة للمولد التزامني ثلاثي الاطوار في ظروف اللاحمل والحمل الكامل مقارنة مع المسيطر التناسبي التكاملية. وقد أظهرت نتائج التمثيل للنظام فاعلية المسيطر الضبابي المقدم. حيث كانت النتائج للمسيطر الضبابي: زمن الأرتفاع= 0,3 ثانية، التجاوز= 0%، زمن الوضع= 0,3 ثانية، الخطأ في الحالة المستقرة= 0%. في حين كان أداء المسيطر التناسبي التكاملية: زمن الأرتفاع= 0,55 ثانية، التجاوز= 20%، زمن الوضع= 2,8 ثانية، الخطأ في الحالة المستقرة= 0%.

1. Introduction

Synchronous generator excitation control is one of the most important measures to enhance power system stability and to guarantee the quality of electrical power it provides. The main control function of the excitation system is to regulate the generator terminal voltage which is accomplished by adjusting the field voltage with respect to the variation of the terminal voltage [1].

Recently, electric power systems have become huge and complicated due to increasing interconnections, installation of large generating units and extra-high voltage tie-lines etc. for that reason, it is difficult to maintain the stability of the system, and the improvement of power system transient stability has become an important issue. To cope with this problem, the conventional controllers such as AVRs (Automatic Voltage Regulators), and PI (Proportional Integral) control for improving the steady state stability of power systems have been equipped with synchronous generators. The excitation voltage E_f that supplied from exciter is controlled by conventional controllers (PI control). Its aim is to keep the terminal voltage V equal to the reference value V_{ref} [2, 3]. However, this controller is designed using a linearized plant and hence will not always work effectively when there are large variations in the operating conditions [3].

Nowadays, intelligent Fuzzy Inference System (FIS) has penetrated deeply into power generation control, in which the nonlinearity of a power system can be considered [4]. Fuzzy control has a

simple control law and is considered to be robust. Further, fuzzy control can take into account uncertainties of un-modeled dynamics since the mathematical model of the power system is not needed. Hence, fuzzy control seems to be quite suitable for controlling synchronous generator excitation system [4].

This paper presents the procedure to design by an adaptive control for a fuzzy inference controller, Which is developed for three phase synchronous generator excitation system and its performance is compared with conventional PI controller for excitation control. The results of the simulation are given.

2. Mathematical Modeling and Simulation of Synchronous Machine:

Figure (1) shows the synchronous generator stator and rotor windings in the dq-axis model; it's obviously that the effect of the field winding appears only in the d-axis, whereas the effect of the damper winding is equivalent to the rotor cage winding of an induction motor, which appears in both dq-axis circuits [5]. The mathematical description of the synchronous machine is as same as all types of AC machines, which have two main problems: first, is the complex 3-phase represented differential equations, and second, is the time varying mutual inductance between stator and rotor winding through dynamic response of the SG [6]. Simply, the first problem can be solved by using axis transformation to transfer the 3-phase parameters and quantities (like: voltage, current, flux....) to 2-phase parameters, which

called Park's transformation or, Park model of SG. In which all stator quantities are transferred from phase a, b and c into equivalent dq axis new variables. Equations (1 to 4) show the approximate Park's transformation by neglecting the zero sequence parameters: [5, 6]

$$P(\theta) = \sqrt{\frac{2}{3}} \begin{bmatrix} \cos(\theta) & \cos(\theta - \frac{2\pi}{3}) & \cos(\theta + \frac{2\pi}{3}) \\ \sin(\theta) & \sin(\theta - \frac{2\pi}{3}) & \sin(\theta + \frac{2\pi}{3}) \end{bmatrix} \dots(1)$$

So ,

$$\begin{bmatrix} V_q^s \\ V_d^s \end{bmatrix} = |P(\theta)| \cdot \begin{bmatrix} V_a \\ V_b \\ V_c \end{bmatrix} \dots(2)$$

$$\begin{bmatrix} I_q^s \\ I_d^s \end{bmatrix} = |P(\theta)| \cdot \begin{bmatrix} i_a \\ i_b \\ i_c \end{bmatrix} \dots(3)$$

$$\begin{bmatrix} \Psi_q^s \\ \Psi_d^s \end{bmatrix} = |P(\theta)| \cdot \begin{bmatrix} \Psi_a \\ \Psi_b \\ \Psi_c \end{bmatrix} \dots(4)$$

The time varying problem can be accomplished by using the synchronously rotating reference frame model, in which all stator variables associated with fictitious winding rotating with the rotor at synchronous speed [6]. The transformation equations are:

$$F(\theta_e) = \begin{bmatrix} \cos(\theta_e) & -\sin(\theta_e) \\ \sin(\theta_e) & \cos(\theta_e) \end{bmatrix} \dots(5)$$

$$\begin{bmatrix} v_q^e \\ v_d^e \end{bmatrix} = |F(\theta_e)| \cdot \begin{bmatrix} v_q^s \\ v_d^s \end{bmatrix} \dots(6)$$

Where:

The superscript notation "s" referred to the stationary frame quantities, and the superscript notation "e" referred to the synchronously rotating reference frame quantities.

Therefore, the synchronously rotating reference frame equivalent circuits of the SG in d^e-q^e axis can be shown in figure (2). Equations (7 to 18) show stator and rotor circuits equations in d^e-q^e axis:

■ *stator equations*: [5, 6]

$$V_{qs}^e = -I_{qs}R_s - \omega_s \Psi_{ds} - \frac{d\Psi_{qs}}{dt} \dots(7)$$

$$V_{ds}^e = -I_{ds}R_s + \omega_s \Psi_{qs} - \frac{d\Psi_{ds}}{dt} \dots(8)$$

■ *rotor equations*: [5, 6]

$$0 = I_{qr}R_r - \frac{d\Psi_{qr}}{dt} \dots(9)$$

$$0 = I_{dr}R_r - \frac{d\Psi_{dr}}{dt} \dots(10)$$

$$V_f = I_f R_f + \frac{d\Psi_f}{dt} \dots(11)$$

Where all rotor parameters are referred to stator circuit and the mutual and self inductance of air gap (main) flux linkage are identical to L_{qm} and L_{dm} rotor to stator reduction.

$$\Psi_{qs} = L_{ls}I_{qs} + L_{qm}(I_{qs} + I_{qr}) \dots(12)$$

$$\Psi_{ds} = L_{ls}I_{ds} + L_{dm}(I_{ds} + I_{dr} + I_f) \dots(13)$$

$$\Psi_f = L_{lf}I_f + L_{dm}(I_{ds} + I_{dr} + I_f) \dots(14)$$

$$\Psi_{qr} = L_{lr}I_{qr} + L_{qm}(i_{qs} + i_{qr}) \quad \dots (15)$$

$$\Psi_{dr} = L_{lr}I_{dr} + L_{dm}(I_{ds} + I_{dr} + I_f) \quad \dots(16)$$

■ **The electromagnetic torque:** [5, 6]

$$T_e = -\frac{3}{2}P_1(\Psi_{ds}I_{qs} - \Psi_{qs}I_{ds}) \quad \dots (17)$$

■ **The motion equation:**

$$T_{shaft} - T_e = \frac{J}{P_1} \frac{d\omega_r}{dt} \quad \dots (18)$$

3. The per Unit (P.U.) d-q Model:

The P.U. d-q model requires base quantities only for the stator. Though the selection of base quantities the following set is widely accepted [5]:

$V_b = V_n \sqrt{2}$ Peak stator phase nominal voltage .

$I_b = I_n \sqrt{2}$ Peak stator phase nominal current.

$S_b = 3V_n I_n$ Nominal apparent power.

$\omega_b = \omega_s$ Rated electrical angular speed ($\omega_s = 2\pi f / P_1$) where P_1 is the number of poles. Base on this restricted set, additional base variables are derived:

$$T_{eb} = \frac{S_b \cdot P_1}{\omega_b} \quad \text{- Base torque.}$$

$$\Psi_b = \frac{V_b}{\omega_b} \quad \text{- Base flux linkage.}$$

$$Z_b = \frac{V_b}{I_b} = \frac{V_n}{I_n} \quad \text{- Base impedance.}$$

$$L_b = \frac{Z_b}{\omega_b} \quad \text{- Base inductance.}$$

Inductances and reactance are the same in P.U. values. Though in some instances time is also provided with a base quantity $t_b = 1/\omega_b$, the inertia is consequently [5, 6];

$$H_b = \frac{1}{2} J \left(\frac{\omega_b}{P_1}\right)^2 \frac{1}{S_b} \quad \dots(19)$$

The P.U. variables and coefficients (inductances, reactance, and resistances) are generally denoted by lowercase letters. Consequently, the P.U. d-q model equations, extracted from equation (7) through equation (18), become [5, 6]:

$$\frac{d\Psi_{qs}}{dt} = \omega_b [-v_{qs}^e - i_{qs}r_s - \omega_s \Psi_{ds}] \quad \dots(20)$$

$$\frac{d\Psi_{ds}}{dt} = \omega_b [-v_{ds}^e - i_{ds}r_s + \omega_s \Psi_{qs}] \quad \dots(21)$$

$$\frac{d\Psi_{qr}}{dt} = \omega_b [i_{qr}r_r] \quad \dots(22)$$

$$\frac{d\Psi_{dr}}{dt} = \omega_b [i_{dr}r_r] \quad \dots(23)$$

$$\frac{d\Psi_f}{dt} = \omega_b [V_f - i_f r_f] \quad \dots(24)$$

$$\Psi_{qs} = l_{ls}i_{qs} + l_{qm}(i_{qs} + i_{qr}) \quad \dots(25)$$

$$\Psi_{ds} = l_{ls}i_{ds} + l_{dm}(i_{ds} + i_{dr} + i_f) \quad \dots(26)$$

$$\Psi_f = l_{lf}i_f + l_{dm}(i_{ds} + i_{dr} + i_f) \quad \dots(27)$$

$$\Psi_{qr} = l_{lr}i_{qr} + l_{qm}(i_{qs} + i_{qr}) \quad \dots(28)$$

$$\Psi_{dr} = l_{lr}i_{dr} + l_{dm}(i_{ds} + i_{dr} + i_f) \quad \dots(29)$$

$$t_e = -(\Psi_{ds}i_{qs} - \Psi_{qs}i_{ds}) \quad \dots(30)$$

$$t_{shaft} - t_e = 2H \frac{d\omega_r}{dt} \dots(31)$$

With t_e equal to the P.U. torque, which it be positive when opposite to the direction of motion (generator mode).

The Park transformation (matrix) in P.U. variables basically retains its original form. Its usage is essential in making the transition between the real machine and d-q model voltages (in general).

$v_d(t), v_q(t), v_f(t),$ and $t_{shaft}(t)$ are needed to investigate any transient or steady state regime of the machine.

By using equations (20 to 31) in P.U form, with ignoring the effect of the damper winding (for simplicity), the per-phase dynamic reference frame model of a synchronous generator can be simulated as shown in figure (3) [5, 6]. This simulation consists of dq-axis stator and rotor dynamic model in which the output stator voltage v_{qs}^e, v_{ds}^e are obtained from the voltage drop across the load resistance (r_L):

$$v_{qs}^e = i_{qs} r_L \dots(32)$$

$$v_{ds}^e = i_{ds} r_L \dots(33)$$

The open loop performance of the S.G. operation under no-load and full-load conditions is illustrated in figure (4).

3. Conventio PI Controller:

The Proportional Integral (PI) controller is a common sense approach to control based on the nature of error. It can be applied to wide varieties of systems [7]. The most applications of the PI controllers in power system control are in the control circuits of power generation plants, either in Load Frequency

Control (LFC) as a power system stabilizer to control the load angle variation and stability of the power system, or as an auxiliary regulating controller inserting in the excitation control system to control and enhance the terminal voltage step response [7].

The two parameters that must be determined (some times, must be optimized) for the given process, to give the desirable output responses for the synchronous generator are: proportional gain (k_p) and integral gain (k_i). The operation principle is to sense the terminal phase voltage and used it as a feedback signal through the PI controller to generate command setting signal which adapt the excited voltage of the S.G, which gives an acceptable behavior of the system for different loads operation. This controller can be easily adapted by using trial and error method to obtain the proportional gain (k_p) and the integral gain (k_i) [8]. The PI controlled system simulation can be shown in figure (5), and the output performance of the system under load variation from no-load to full-load operation is shown in figure (6), with $k_p=0.5$ and $k_i=5$. When these results are compared with the open loop performance it's found that these settings of K_p and K_i produce a good overall response.

4. Fuzzy Logic Control (FLC):

Since fuzzy logic (FL) was introduced by Lotfi Zadeh in 1965, it had many successful applications mostly in control. One of the main advantages of fuzzy logic system is the design on the basis of incomplete and approximate information, thus providing simple and fast approximations of the unknown or too complicated models [6, 9].

The main idea of fuzzy control, which had proved to be a very

successful method, is to build a model of human control expert who is capable of controlling the plant without thinking in terms of mathematical model. However, the main benefits provided by the Fuzzy Logic Controllers (FLCs) are listed below [9]:

- FLCs can deal with ill-defined systems of unknown dynamics that do not require a priori mathematical model of the plant for implementation, as required by many traditional adaptive controllers.
- FLCs provide a formal methodology for representing, manipulating, and implementing human heuristic knowledge about how to control a system.
- FLCs are customizable, since it is easier to understand and modify their rules, which do not only use a human operator's strategy but also are expressed in natural linguistic terms.
- Software design and hardware implementation supports are suitable for real time applications.

On the other hand, the main limitations of this technology include the following [9].

- FLCs lack capability of learning and have no memory.
- The selection of Membership Functions (MFs) for the input and output variables and the determination of fuzzy rules are not always easy. There is no formal framework for the choice of the parameters of FLC and hence the means of tuning them and learning models in general have become an important subject of fuzzy control.

- For multivariable processes, the number of rules increases rapidly for multiple input systems.
- It is implicitly assumed that significant process changes do not occur during operations that are outside the operators experience and this point represents a drawback in the design approach.
- Fuzzy design is still generally heuristic methodology for which no analytical tools exist to verify or validate the controller performance and stability.

Sugeno fuzzy-control technique belongs to the robust controller category, which deals with model uncertainties of simplified model. These uncertainties may come from un-modeled dynamics, variations in system parameters, or approximations of complex plant behaviors. The Sugeno fuzzy-controller is a particular type of varying structure system featuring prescribed behavior of the closed system and robustness to parameter variations and external disturbances. Sugeno fuzzy-control is a powerful approach to solve system state tracking problems. The architecture of Sugeno fuzzy-control is simple and its design is directly oriented toward nonlinear systems, no linearization is needed [9, 10].

5. Adaptive Neuro-Fuzzy System:

As mentioned before, that the design of MFs and the rules table of a fuzzy inference system was based on the experience of the operator or designer of the system. This means that there is no systematic method for design of a fuzzy system. On the other hand, in a neural network the experimental or simulation input/output data can be used to train a network. The network then represents the model which satisfies

that data. These techniques can be brought into a hybrid neuro-fuzzy system to build a more powerful intelligent system with improved design and performance features called Adaptive Neuro-Fuzzy Inference System ANFIS [6]. As name indicates, a fuzzy inference system is designed systematically using the neural network design method [6, 11]. This means that if the desired input/output data patterns are available for a fuzzy system, the MFs and rules table can be designed using the neural network training method.

Usually the sugeno method is used in adaptive neuro-fuzzy system. For example: if X & Y are the inputs of the fuzzy system, and "F" is the output signal:

IF X is A₁ AND Y is B₁ THEN z=f₁

IF X is A₂ AND Y is B₂ THEN z=f₂

The output "F" can be constructed as:

$$F = \frac{W_1}{W_1+W_2} f_1 + \frac{W_2}{W_1+W_2} f_2 \dots\dots (34)$$

Where: A₁, A₂, B₁, B₂ are the input MFs, f₁ and f₂ are the output singleton MFs, and W₁ and W₂ are the Degree Of Fulfillments (DOF) of rule 1 & 2, which can be adaptive by using any training algorithm to satisfied the input/output data [6, 11].

6. Design of an Adaptive Neuro-Fuzzy Controller:

A discrete adaptive neuro-fuzzy controller can be implemented to control the excitation voltage of the S.G. This type of controller can be adapted to modify the nonlinearity feedback signal of the S.G. output voltage to satisfy the input reference command signal. A discrete time delay function is used to create a comparison between the previous error signal e(k-1) and the instant

plant output y(k). These two signals are the inputs of the fuzzy system as shown in figure (7), which must be recognize the state of the system and predicts a suitable linear feedback signal f(k). According to that function of the fuzzy controller, an adaptive controller of two inputs and three triangle MFs of each input is used in this work which has the structure shown in figure (8). The output MFs and rules are adapted by using neural training algorithm of large number of input and output data set. The fuzzy system input MFs and the input/output surface performance are shown in figure (9) & figure (10) respectively. The accuracy performance of the designed neuro-fuzzy inference system between the desired output and fuzzy output is shown in figure (11). The final performance of the synchronous generator with neuro-fuzzy inference controller under no-load and full-load condition is illustrated in figure (12).

6. Conclusions

Figure (13) shows a comparison performance between the open loop, PI controller, and the neuro-fuzzy controller. The conclusions of this work can be summarized in three steps as following:

- 1- In open loop operation of the three phase synchronous generator, the terminal voltage step response is very slowly and the terminal voltage step response is not exactly equal to the desired values especially under load condition which gives a very high steady state error.
- 2- In the conventional PI controller, the synchronous generator give a good behavior under no-load and full-load condition with respect to the open loop performance which can be illustrated as follow:

- Rise time response: 0.55 sec. (good).
 - Settling time: 2.8 sec. in no-load and 2 sec. in full-load (poor).
 - Maximum overshoot: more than 20% in no-load (poor) and 6% in full-load (good).
 - Steady state error: 0% in both of no-load and full-load (very good).
- 3- In the neuro-fuzzy Controller the synchronous generator proposes an excellent performance in both of no-load and full-load operation as follow:
- Rise time: 0.3 sec. (very good).
 - settling time: 0.3 sec. (very good).
 - Maximum overshoot: 0% (very good).
 - Steady state error: 0% in both of no-load and full-load condition (very good).

Obviously, from which one can deduced that; the Fuzzy controller has the best response than others because it's highly improved the terminal voltage step response. Therefore, it can be used successfully instead of complex controller methods or traditional controllers.

References:

- [1] R. Patel, T. S. Bhatti and D. P. Kothari, "MATLAB/ Simulink-Based Transient Stability Analysis of a Multi-Machine Power System", Journal: International Journal of Electrical Engineering Education, Vol. 39, Issue 4, October, 2002.
- [2] T. Senjyu, Y. Morishima and T. Arakaki, "Improvement of Multi-Machine Power System Stability Using Adaptive PSS", Electrical Power Components and Systems, 30:361-375, 2002.
- [3] T. Senjyu, T. Yamashita and H. Fujita, "Stabilization Control for Multi-Machine System Using Decentralized of Excitation Controller Realizing Terminal

Voltage Control and Damping Control", Electrical Engineering in Japan, Vol. 1, 2004.

[4] T. Senjyu, A. Miyazato and K. Uezato, "Enhancement of Transient Stability of Multi-Machine Power Systems by Using Fuzzy-Genetic Controller", Journal of Intelligent and Fuzzy Systems, Vol. 8, 2000.

[5] Ion Boldea "Synchronous Generators", Handbook, Taylor and Francis Group, 2006.

[6] Bimal K. Bose, "Modern Power Electronic and AC Drives", Prentice Hall, 2002.

[7] Y. Katauchi, T. Shirasaki, K. Hayashi, M. Banjo, and S. Kitamura, "Recent Developments on Generator Excitation Control System: Introduction of Digital AVR and Power System Stabilization", Hitachi Review, Vol.49, No.2, pp. 66-70, 2000.

[8] Lina J. Rashad, "Excitation and Governing Control of a Power Generation Based Intelligent System", Ms.c. thesis, University of Technology, Iraq, 2008.

[9] K. M. Passino and S. Yurkovich, "Fuzzy control", Addison – Wesley Longman, 1998.

[10] C. C. Wong and B. C. Hung, "Genetic-Based Sliding Mode Fuzzy Controller Design", Tamkang Journal of Science and Engineering, Vol.4, No.3, 2001.

[11] A. A. AL-Annie, "Structural Design Methodology of Genetic Fuzzy Controller for Nonlinear Control Systems", Ph.D. Thesis, Al-Rasheed Collage of Engineering and Science at the University of Technology, 2005.

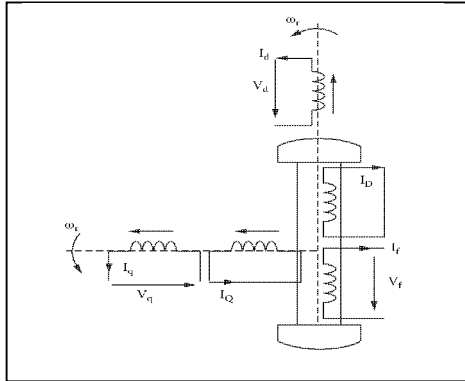

Figure (1) S.G. Windings in dq-axis

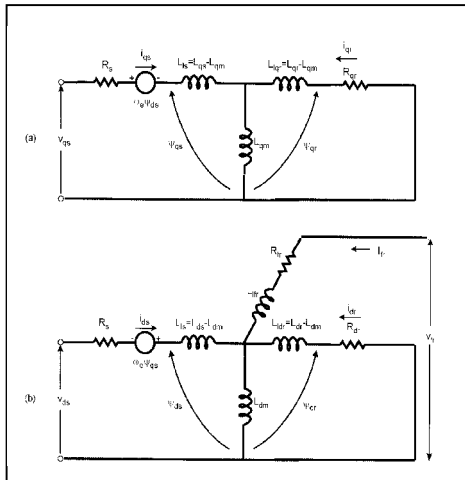

Figure (2) Stator and Rotor Equivalent Circuits in dq-axis

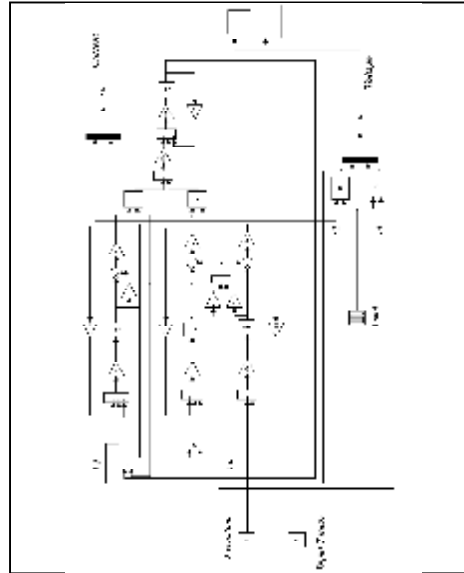

Figure (3) SG Simulation

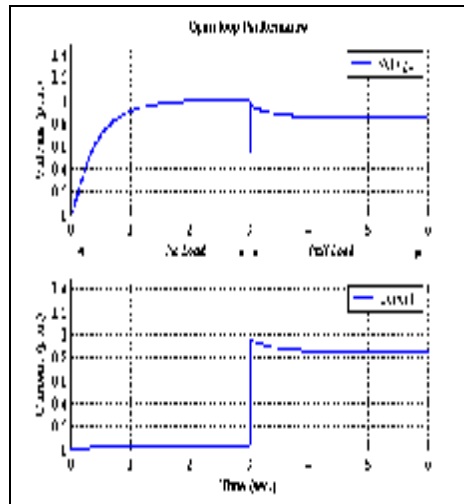

Figure (4) Open Loop Performance

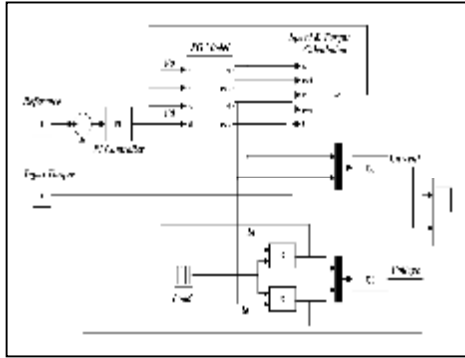

Figure (5) PI Controller System Simulation

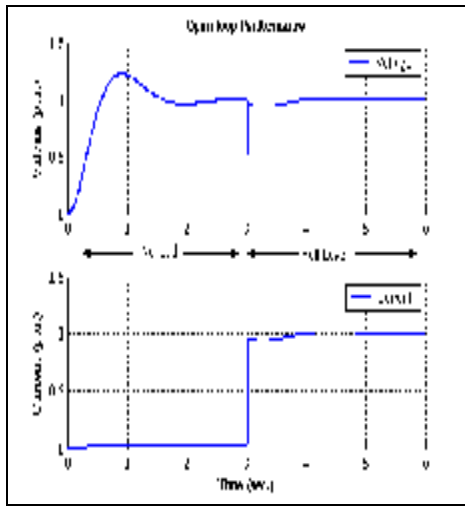

Figure (6) PI Controller System Performance

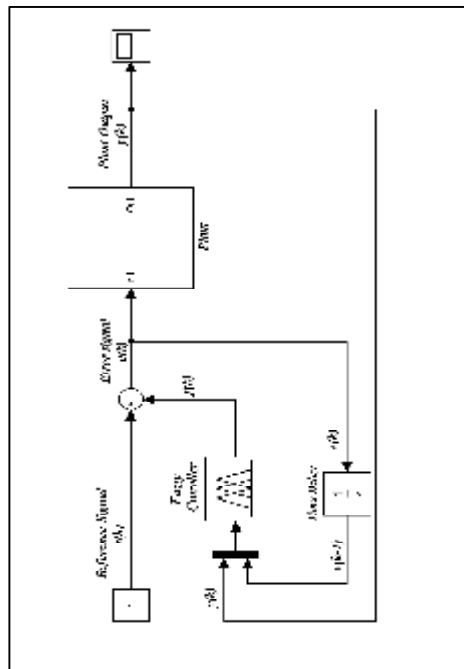

Figure (7) Neuro-Fuzzy Controller Simulation

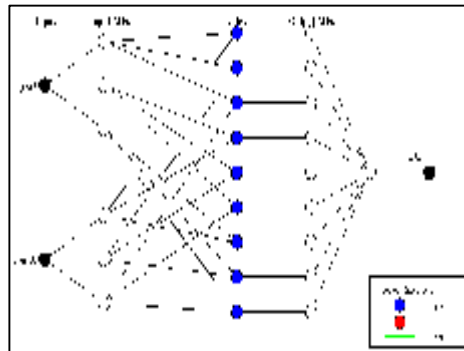

Figure (8) Fuzzy Network Structure

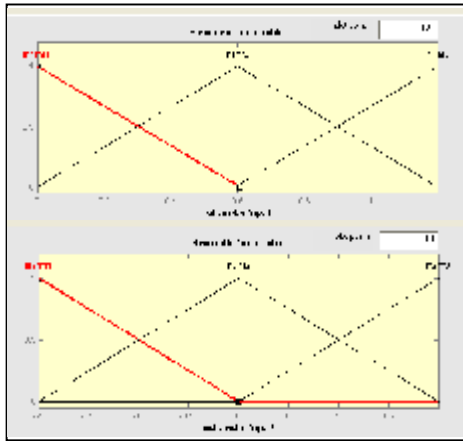

Figure (9) Inputs Membership Functions

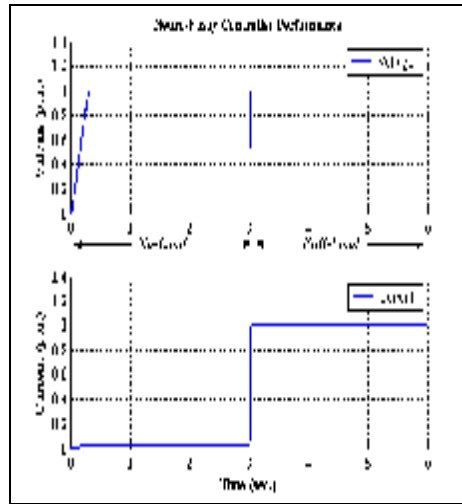

Figure (12) Neuro-Fuzzy Controller System Performance

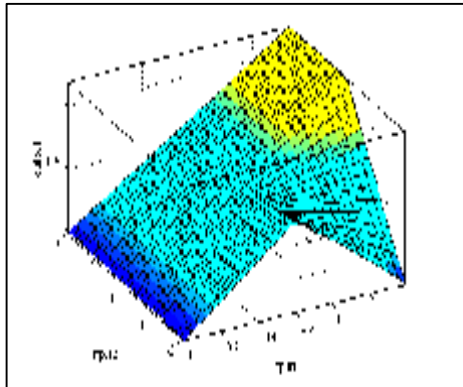

Figure (10) ANFIS Input/output Surface Performance

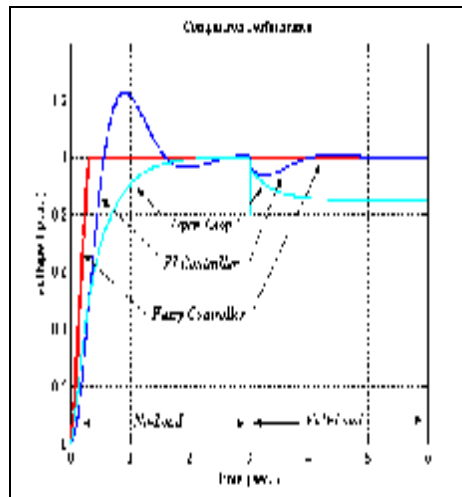

Figure (13) Comparison Performance between Open Loop, PI, and Fuzzy Controller

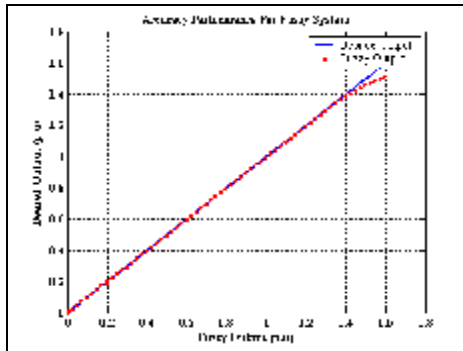

Figure (11) Accuracy Performance for Fuzzy Controller System