

Active Directory Monitoring System Using Optimized Web Database Application And AJAX Techniques

Dr. Mohammed Najm Abdullah 

Received on: 9/3/2010

Accepted on: 5/ 8/2010

Abstract

The process control network and subscribers to extract information entry and exit, supported them by providing time for the cases of entry and exit, and archiving in databases has become one of the basic requirements of each organization

In this paper, we propose designing a system control and monitoring of participants within the scope (Domain) by taking advantage of the previous registration system (Active Directory) through the use of modern techniques to ensure speed and protection, that is (ASP.Net) and Asynchronous JavaScript and XML (AJAX) technology with data storage in using archive (MS SQL Server)

The implementation results show the capability of AJAX that meets the optimal performance through implementing an employee's logins monitoring system. This is done through taking the benefit of Microsoft domain server logs file that records the logins for all employees linked to that domain and collecting these information to be nicely showed in web report automatically every day. This daily task is controlled by using Microsoft tasks schedules linked to Microsoft SQL server tasks. So this implementation of the employee's logins monitoring system illustrates the building of a system using Microsoft IIS, Microsoft SQL 2000, AJAX, and Microsoft.NET Framework to create powerful control web applications.

Keywords: Active Directory ; Web Monitoring ; Web Applications; AJAX

نظام مراقبة الدليل الفعال بأستخدام قواعد بيانات تطبيقات الشبكة المثلى وتقنيات أجاكس

الخلاصة

ان عملية مراقبة مشتركى الشبكة واستخراج معلومات الدخول والخروج لهم مدعما بتزويد الوقت لحالتي الدخول والخروج وارشفتها في قواعد البيانات اصبحت من المتطلبات الاساسيه لكل منظمه. في هذا البحث نقترح تصميم نظام يسيطر ويراقب المشتركين داخل مجال (Domain) من خلال الاستفاده من تسجيلهم السابق في نظام (Active Directory) عن طريق استخدام التقنيات الحديثه التي تضمن السرعة والحمايه وهي (ASP.Net) وتقنية (AJAX) مع خزن البيانات في ارشيف باستخدام (MS SQL Server). تظهر نتائج التنفيذ قدرة تقنية اجاكس, التي تلبي الاداء الامثل, من خلال تنفيذ نظام مراقبة وتسجيل الدخول للمشاركين. وقد تم ذلك من خلال الاستفاده من ملفات تسجيل المجال (Domain) لخدم المايكروسوفت حيث انه يقوم بتسجيل جميع المستخدمين لهذا المجال مع جمع المعلومات الخاصه بأوقات دخولهم وخروجهم من المجال و يجب ان تظهر بشكل جيد في تقرير الشبكة يوميا وبصوره تلقائيه. ان هذه المهمه اليوميه تتم من خلال تحكم بداول المهام لخدم مايكروسوفت يمكن القول ان بناء نظام مراقبة تسجيل مستخدمين للمجال قد تم من خلال استخدام نظام اداره شبكة الانترنت (Microsoft IIS) و Microsoft SQL 2000 وتقنية الاجاكس مع منصة Microsoft.NET لإنشاء تطبيقات الشبكة ذات السيطرة الفعاله.

Introduction

Web applications are among the fastest growing classes of software systems in use today. These applications are being used to support a wide range of important activities: business functions such as product sale and distribution, scientific activities such as information sharing and proposal review, and medical activities such as expert-system based diagnoses. Given the importance of such applications, faulty web applications can have far-ranging consequences on businesses, economies, scientific progress, and health [1]. The Internet has introduced a new era of computing. Nowadays, the Web is extensively used as a major means of communication with the external world as well as means of communication within an organization, and also as a tool to assist in carrying out its business process in a more effective way. Hence Web applications, which have been specifically designed for web-based environment, have received a lot of attention in the IT industry. Some examples of Web applications are: web mail, e-commerce, e-malls (online shopping mall), online auctions, process monitoring, logistics control, online-education and many more [2].

1. The role of AJAX in web applications

Recently, a new web development technique, dubbed AJAX [3]. In this new model, the (single-page) web interface is composed of individual components which can be updated/replaced independently, so that the entire page does not need to be reloaded on each user action. This, in

turn, helps to increase the levels of interactivity, responsiveness and user satisfaction [4]

AJAX is a useful tool for creating web database application. Using AJAX provided a lot of facilities through using frameworks that contains the desired functions and procedures that can be used in any web-database application, moreover these functions and procedures may have the same duties as using any other server side scripting language but not with the traditional databases which cannot adequately handle rich data such as nested data structures or complex documents, which are characteristic of typical Web content. The XML databases, on the other hand, store XML data natively in its structured, hierarchical form [5].

The XML allows developers to create Web pages and to set standards for defining the information that will appear in a document with the related sequence. XML, in combination with other standards, makes it possible to define the content of a document separately from its formatting, and this will help to reuse that content in other applications or for other presentation environments. Most important, XML provides a basic syntax that can be used to share information between different kinds of computers, different applications, and different organizations without needing to pass through many layers of conversion. In addition, XML has been designed to be extremely expressive and very well structured while at the same time being easy for both human beings and computer programs to read and write.

Thus, it's an obvious choice for exchange languages [6].

2. The Architecture of Web Applications

The basic architecture of a web application includes browsers, a network and a web server as illustrated in figure (1). Browsers request web pages from the server. Each page is a mix of content and formatting instructions expressed with HTML. Some pages include client side scripts that are interpreted by the browser. These scripts define additional dynamic behavior for the display page and often interact with the browser, page content and additional controls (Applets, ActiveX controls and plug-ins) contained in the page. The user views and interacts with the content in the page. Sometimes the user enters in information in field elements in the page and submits them to the server for processing [7]. The user can also interact with system by navigating to different pages in the system via hyperlinks. In either case, the user is supplying input to the system that may alter the business state of the system [8].

3.1 The proposed system objectives

The objectives of the proposed architecture can be summarized as follows:

Building a web-database monitoring system supported with strong search engine in addition to taking care of the security and speed in giving exact results and showing the employees logins to their computers regarding all working hours and shifts employees or part time schedules. All this information displayed using a friendly

user interface reports showing all the monitoring process automatically as a daily task.

Show the architecture of building a standard and secure web database application through adding AJAX technology and its related tools and making use of the XML embedded database as a middle tier database to increase the speed of the data exchanging operation.

Using Microsoft facilities that make the link with XML and making XML middle-tier database. The links will be through using the classes and objects for making a link with the relational database, and other link through using the objects of scripting languages (such as VB script, Java script or C# script) that runs inside the website pages either with using the classes and methods that are provided by Microsoft Framework.

Mainly to build a fast, dynamic website, but also to save resources. For improving sharing of resources, it is better to use the power of all the client computers rather than just a unique server and network. Ajax allows performing processing on client computer (in JavaScript) with data taken from the server. The processing of web page formerly was only server-side, using web services or ASP.NET scripts, before the whole page was sent within the network. But Ajax can selectively modify a part of a page displayed by the browser, and update it without the need to reload the whole document with all images.

3.2 The Architecture of the Proposed Web-Database Monitoring System

This article illustrates the practical implementation for the building of three-tier system using AJAX, ASP.NET and XML as a middle-tier database between the relational database server and the web server. The building of a typical three-tier Web database application system using MSXML Server XMLHTTP to facilitate the communication through the HTTP with reliable software implementation using ASP code, C# COM objects and Microsoft SQL Server 2000 simplifies building Web based database applications. Figure (2) shows the proposed Three-Tier Web-Database Monitoring Architecture. This architecture is used to realize the Employee's Logins Monitoring system.

3.3 Employee's Logins Monitoring System

The flowchart of the employee's logins monitoring system is shown in figure (3), this system has the ability to extract the required information from the database through querying this information in the backend when the user or client's request comes from the web search engine, after the web server pass the request to the database server, the database server will execute the query in the backend and pass the query's result to the web server, here the web server will pass this information in well designed GUI to be previewed nicely to the client as shown in figure (4). Here the powerful of using Microsoft SQL server in storing the data in well designed and

protected database spread in a lot of relational tables.

The Employees Logins Database tables are shown in figure (5). These tables are designed and implemented using MS SQL server 2000 to store all the information regarding the records comes from the exchange server to be managed later by the employee logins application as an electronic archived data.

The communication was done through the HTTP over the WWW. Also, Microsoft Framework classes were been used. This web-database application enables the authorized users to control and monitor on the data that stored in tables of the SQL 2000 database through the HTTP over the Web by using friendly WebPages and layouts.

3.4 System Requirements

The Employees' logins monitoring system requires hardware and software installations on the servers' computer as the following:

- a. Processor: Pentium IV or Advanced Micro Devices (AMD) with at least 1.4 GHz.
- b. Read Access Memory (RAM): 512 MB.
- c. Operating System: Microsoft Window 2000 advanced server can be used, but it is more reliable to use Windows 2003 (Enterprise or Web Edition) because its IIS is version 6.0. or IIS 5.0 that comes with previous versions such as Windows 2000 server and Windows XP.

- d. SQL Server 2000 (As a database server for data storage).
- e. IIS on the web server to communicate with the clients through HTTP.
- f. MSXML 3.0 or higher versions.
- g. XML for SQL Server 2000 Web Release 1.0.

3. Results & Discussion

As a result a web application was designed and developed successfully that can be run on Intranet or even Internet. This application have the ability to control and monitor all the linked servers inside an organization supported by valuable reports and GUIs that facilitate the process of monitoring, all the important information stored in relational database in order to insure the speed in data management and keep these information safe as much as possible.

ASP.NET is used daily by millions of professional developers world-wide. It runs some of the most successful websites and applications in the world, and every day thousands of new developers begin learning ASP.NET for the first time—supported by an incredible developer community of books, blogs, user groups, forums, and developer websites.

The goal with ASP.NET AJAX is to enable developers to easily build great ASP.NET applications that fully leverage the power of the browser, and which deliver a smoother and more interactive experience for end users. ASP.NET AJAX works with all modern browsers, and allows to easily

building great web applications that work cross-platform on all operating systems. ASP.NET AJAX 1.0 is available as a free, fully supported download for ASP.NET 2.0. It will be built into the standard .NET setup package starting with the .NET Framework 3.5 release of ASP.NET.

There are several things that distinguished through ASP.NET AJAX. The first is the productivity it delivers. ASP.NET AJAX can be used to very quickly add common AJAX behavior and functionality to an application with very minimal code. If you want smoother page updates and richer client-UI behaviors, there isn't another AJAX framework out there that makes it easier.

What is great about ASP.NET AJAX is that it also scales to advanced scenarios. One can use the ASP.NET AJAX client-side JavaScript library to build clean, encapsulated JavaScript that makes asynchronous network callbacks to the server to build extremely rich UI. This ability to start simple, but then go deep, using a core AJAX programming model that is nicely integrated into ASP.NET, ends up being extremely powerful, and is one that enables developers to build great next-generation web applications.

ASP.NET AJAX in Action provides an excellent guide to learning and mastering all of the functionality that ASP.NET AJAX provides, and in particular it does a great job of explaining its more advanced features [9].

Ajax uses a programming model with display and events. These events are

user actions; they call functions associated to elements of the web page.

Interactivity is achieved with forms and buttons.

4. Conclusions:

This system was designed, analyzed, developed and tested and all the results matched the goals that were planned in the design model. This monitoring system shows the ability of taking benefit from the Domain controller (from the event window) which has the ability to record every single action to any Computer linked to that domain so all the logs were taken from the domain and placed this information in text files automatically every day in a folder inside the web server, then the action of the web server begins in collecting the information from the text files and putting all the records in the Microsoft SQL server so XML can reach this database and show this information in well designed web reports after using the search engine in querying any employee inside the domain or in other word inside the organization.

Finally, the use of ASP technology has made it easier to design and develop the three-tiered architecture of this application. We were using the Microsoft Software Development Platform for the development of this project, which had given a complete, tight and integrated approach for the process of design and development of the Employee Logins Monitoring System.

5. References:

- [1] Sebastian Elbaum, Srikanth Karre, Gregg Rothermel, "Improving Web Application Testing with User Session Data", Software Engineering, 2003. Proceedings. 25th International Conference on Software Engineering, 2003.
- [2] Wei Huang; Ru Li; Maple, C.; Hongji Yang; Foskett, D.; Cleaver, V.; "Web Application Development Lifecycle for Small Medium-sized Enterprises", The Eighth International Conference on Quality Software, IEEE computer society, 2008.
- [3] Steven Holzner, "Ajax: A Beginner's Guide", The McGraw-Hill Companies, 2009.
- [4] Ali Mesbah, "Ajaxifying Classic Web Applications", the 29th International Conference on Software Engineering - Companion, ICSE, 2007.
- [5] J. Harbarth, "XML: The universal data format for integrated electronic business solutions", Software AG XML Company, 2004.
URL:
http://www.softwareag.com/xml/about/xml_why.htm
- [6] S. Laurent, "Create Web pages and much more, with Extensible Markup Language", Web Developer's Journal, Nov.8, 1999.
URL:
http://webdevelopersjournal.com/articles/why_xml.html
- [7] Jingfeng Li; Jian Chen; Ping Chen; "Modeling Web Application Architecture with UML", Asia 2000. Proceedings, 36th

- International Conference on
Technology of Object-Oriented
Languages and Systems 2000,
- [8] Shauvik Roy Choudhary and
Alessandro Orso, “Automated
Client-side Monitoring for Web
Applications”, IEEE International
Conference on Software Testing
Verification and Validation
Workshops, ICSTW.2009
- [9] ALESSANDRO GALLO, DAVID
BARKOL forwarded by Scott
Guthrie (General Manager,
Developer Division in Microsoft
Corporation) “ASP.NET AJAX in
Action”, 2007.

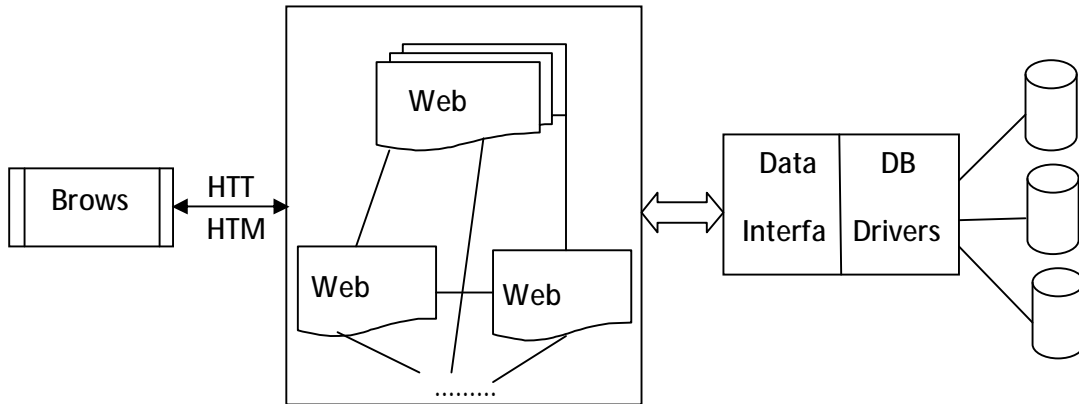

Figure (1): Basic Architecture for Web Applications

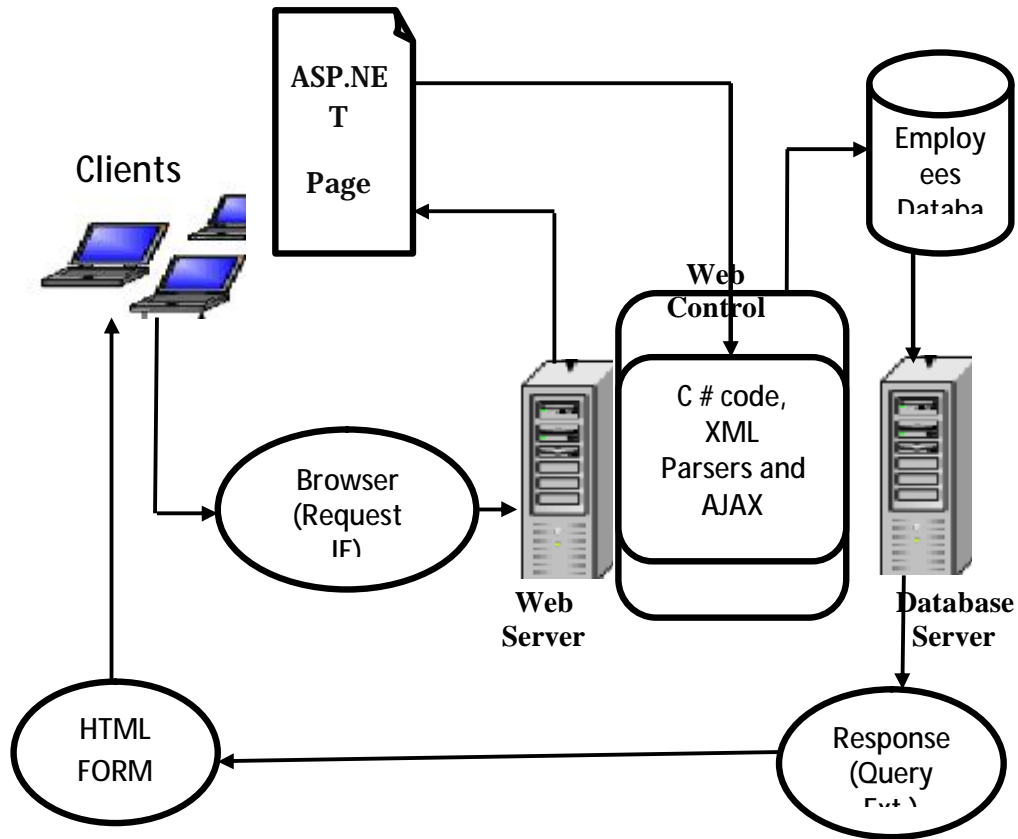

Figure (2): The proposed Three-Tier Web-Database Monitoring System.

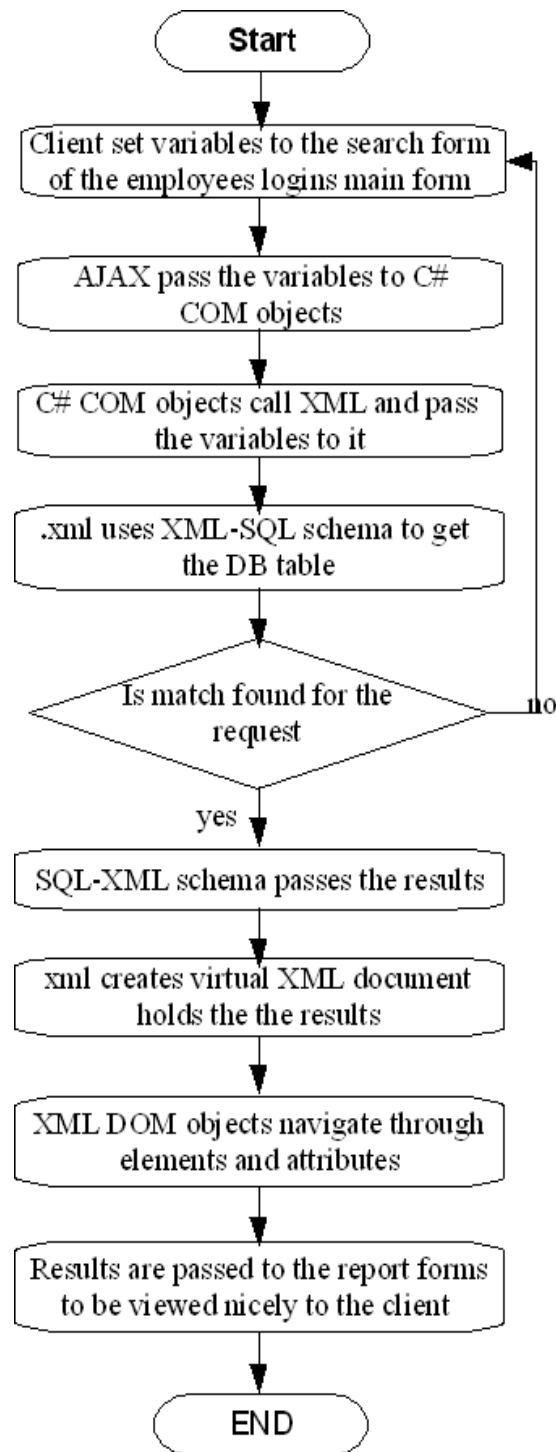

Figure (3): Employee Logins Procedure flow chart

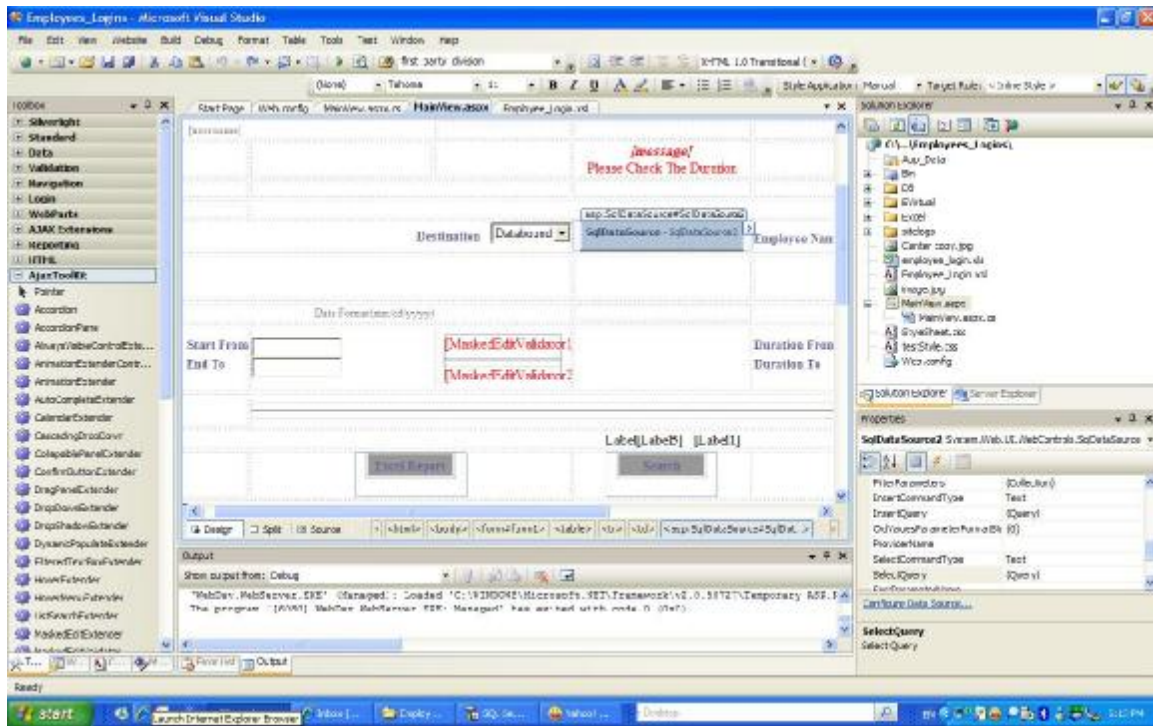

Figure (4): Employee Logins Monitoring System

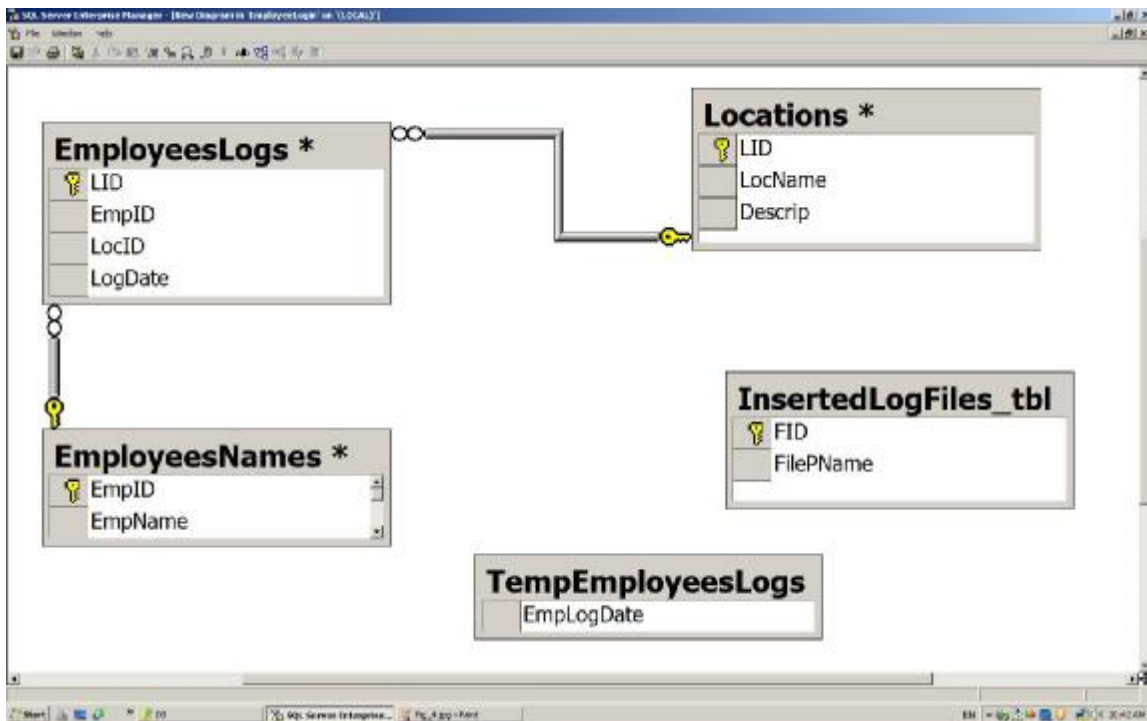

Figure (5): Employees Logins Database tables