

DYNAMIC SYSTEM IDENTIFICATION USING TIME-DELAY FEEDFORWARD NEURAL NETWORKS: APPLICATION TO DC MOTOR

Ali Khudhair Mutlag

Engineering College , Diyala University
(Received:11-1-2009 ; Accepted:22-3-2010)

ABSTRACT - The universal function approximation capabilities of multilayer feedforward neural networks make it a popular choice for modeling dynamic systems. In this paper, identification of dynamic system using time-delay feedforward neural networks with application to DC motor as a case study has been developed. The developed neural network model is a three layer network with nonlinear (*sigmoid*) activation functions in the hidden layer and linear output layer with input-output delays. Simulation results showed that the neural networks are promising tool for dynamic system identification.

KEY WORDS:- System Identification, Neural Networks, DC Motor.

1- INTRODUCTION

In control community, modeling is termed *system identification*. Its main purpose is to identify a model of unknown plant (system) in order to predict and gain insight into the behavior of the plant. So, one of the fundamental topics addressed by control engineering is the neural networks based system identification, as a promising strategy for coping with the difficulties arisen by nonlinear model construction of dynamic systems. The Field of system identification has become important discipline. Identification is basically the process of developing or improving a mathematical representation of a physical system using experimental data⁽¹⁾. The artificial neural network is a newly developed technique among the identification methods. System identification is a vital problem in many fields of automatic control, signal processing, communication systems, adaptive control, and power spectrum estimation⁽¹⁾.

Dynamic system is a system that changes during time. Basically, all real systems are dynamic systems. They are described by differential equations (transfer functions) that govern the response of the system. These equations are the foundations for controlling the system response. Therefore, modern control theory requires accurate mathematical model in order to design appropriate controllers based on a predefined requirements⁽²⁾. Once the mathematical model has been defined, it can be characterized in terms of suitable descriptions such as transfer function, impulse response or power series expansions. One of many problems that face the control engineer in many applications is to control a system with unknown dynamics, thus, the differential equations which govern the response of the system is undefined. Another problem deals with the inherent nonlinearity of the most real-world dynamic systems making the modeling process very difficult using traditional modeling methods such as Newton laws, energy and mass conservation laws. These approaches need deep understanding of the underlying mechanisms that govern the system behavior. In practice, these *mechanisms* approach have a couple of disadvantages:-

1. The development time of the model is long.
2. The values of some parameters of the model may be uncertain due to lack of information and due to fact that they must be determined empirically.

The remedy for such problems is Artificial Neural Networks (ANN) because:-

- Neural network can learn (identify) the transfer function of a system from its input-output data.
- They offer versatile input-output mapping capabilities.
- Neural network models have a considerable tolerance for input noise.
- They can deal with time varying input/output through their own natural temporal operation.

Ping and Lihua applied Diagonal Recurrent Networks (DRN) to identify the dynamical performance of hydraulic servo system⁽¹⁾. Nechyba and Xu provide network architectures with variable size and activation functions for static and dynamic system identification with application of nonlinear controller for inverted pendulum system⁽³⁾.

So, this paper presents the application of ANN for dynamic system identification, feed forward time-delay neural network model for DC motor has been proposed as a case study. A network with two input delays, two output delays, six hidden neurons with nonlinear activation functions show satisfactory results in capturing the dynamics of DC motor especially for testing and validation training data.

2- ARTIFICIAL NEURAL NETWORKS(ANN)

Artificial neural networks are composed of a number of neurons or units connected by links. Each link has a numeric weight (w) and bias (b) associated with it. Weights and biases are primary means of long-term storage in a neural network, and learning usually takes place by updating them⁽⁴⁾. Each neuron has a set of input links from other neurons, a set of output links to other neurons, and activation function. A neuron with a single input is shown in Figure (1). The input u is transmitted through a connection that multiplies its strength by the weight w , to form the product wu . The bias is added to the weighted input wu to form the argument of the transfer function f , which produces the scalar output⁽⁴⁾ y :

$$y = f(wu + b) \quad \dots(1)$$

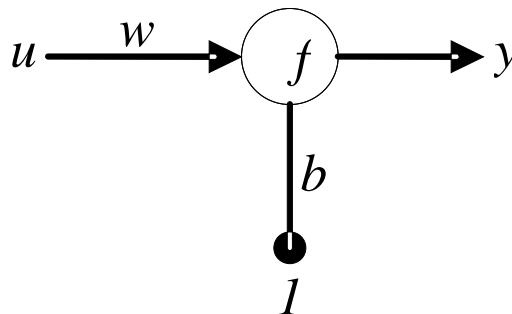

Fig.(1):- Single Neuron

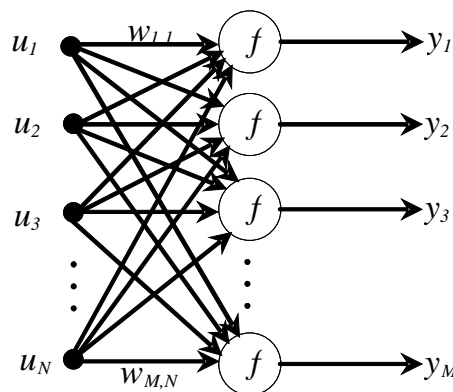

Fig.(2):-Layer of Neurons

A single layer of neurons is shown in Figure (2), in this network, each element of the input vector \mathbf{u} is connected to each neuron input through the weight matrix \mathbf{W} .

$$\mathbf{W} = \begin{bmatrix} w_{1,1} & w_{1,2} & \dots & w_{1,N} \\ w_{2,1} & w_{2,2} & \dots & w_{2,N} \\ \cdot & \cdot & \dots & \cdot \\ w_{M,1} & w_{M,2} & \dots & w_{M,N} \end{bmatrix} \quad \dots(2)$$

The i th neuron has a summer that gathers its weighted inputs and bias to form its own scalar output n_i . The various n_i is taken together to form an M -element net input vector \mathbf{n} . Finally, the neuron layer outputs form a column vector \mathbf{y} ⁽⁵⁾

$$\mathbf{y} = \mathbf{f}(\mathbf{W}\mathbf{u} + \mathbf{b}) \quad \dots(3)$$

The input vector elements enter the network through the weight matrix \mathbf{W} . A network of M neurons with N inputs can be shown in Figure(3). Where \mathbf{u} is an N length input vector, \mathbf{W} is an $M \times N$ matrix, \mathbf{y} and \mathbf{b} are M length vectors. As defined previously, a layer of neurons includes the weight matrix \mathbf{W} , the multiplication operations, the bias vector \mathbf{b} , the summer, and transfer function.

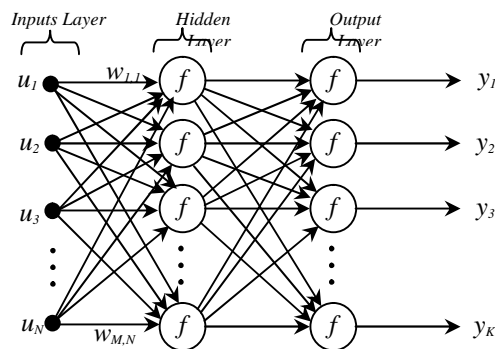

Fig.(3):- Multiple Layers of Neurons

A network can have multiple layers each layer has a weight matrix \mathbf{W} , a bias vector \mathbf{b} , and an output vector \mathbf{y} . The layers of a multilayer feedforward neural network can be classified into three types, a layer that receive input signals is called *input layer*, a layer that produces network output is called *output layer*, all other layers between them are called *hidden layers*. The three-layer network shown earlier has input layer, output layer, and one hidden layer. Multilayer networks are quite powerful. For instance, a network with a hidden layer of nonlinear (*sigmoid*) transfer function and the output layer of *linear* transfer function, can be trained to approximate any function (with a finite number of discontinuities) arbitrarily well⁽⁵⁾. Unfortunately, Feedforward networks cannot perform temporal computation. So, More complex networks with internal feedback (delay) paths are required for temporal behavior. Thus, when a network contains delays, i.e. the input/output to the network would be a

sequences that occur in a certain time order, such networks are called *time-delay networks*⁽⁶⁾. Figure (4) shows example of a simple time-delay networks. These networks have important capabilities that are not found in feedforward networks, such as attractor dynamic and the abilities to store information for later use. The particular interest is their ability to deal with time varying input or output through their own natural temporal operation. Thus the time-delay neural networks are a dynamic mapping and it is better suited for dynamical system than traditional feedforward network⁽⁷⁾.

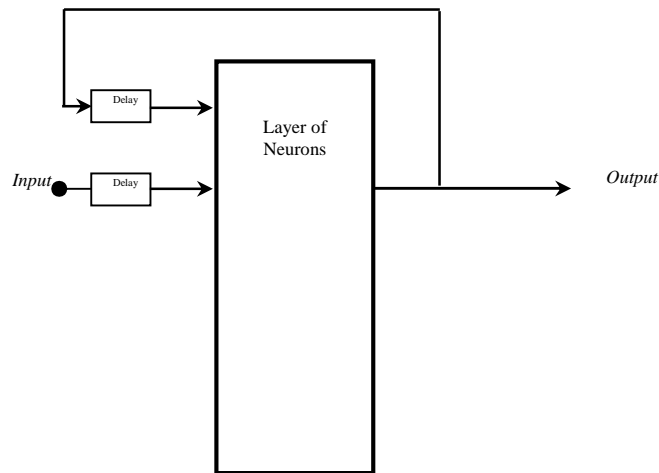

Fig.(4):- Time-Delay Network

3- NEURAL NETWORK IDENTIFICATION MODEL

The artificial neural network is a newly developed technique among the identification methods. Figure(5) shows the general block diagram for neural network system identification. In system identification, the *unknown* plant output and neural network model output are compared, and the error is fed back to a learning algorithm, which modifies the model in an attempt to reduce the error. The prediction error between the plant output and the neural network output is used as the neural network training signal.

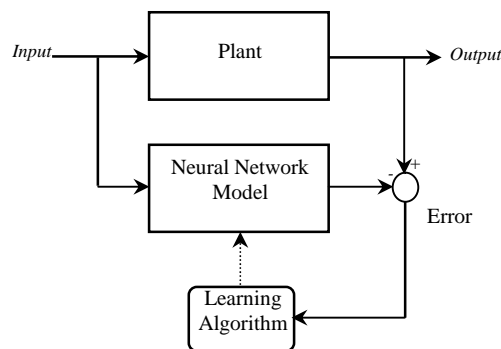

Fig.(5):- System Identification Block Diagram

The neural network plant model uses previous (delayed) inputs and previous (delayed) plant outputs to predict future values of the plant output⁽⁸⁾. The structure of the neural network plant model is given in Figure (6). This network can be trained offline in batch mode, using data collected from the operation of the plant. There are three steps in system identification procedure :-

- 1- Collect experimental input/output data.
- 2- Select and train the neural network model.
- 3- Validate the model.

Input-output data must be collected experimentally or by using a mathematical model of the plant (if available) to form training data for the neural network model. These data had been splitted into three parts, training, validation, and testing data. Generally, half of the input-output data had been used for training the neural network model (updating the weights and biases), one-fourth had been used for validation of the network, and also one-fourth had been used as a new (never seen before) data to test the network.

In designing and training a neural network model to identify a dynamic system, the only fixed parameters are the number of inputs and outputs to the network, which are based on the input/output variables of the system, while the number of hidden layers and the size of each layer are up to the designer. In fact, three-layer network with nonlinear (sigmoid) activation function at hidden layer and linear activation function at output layer, can approximate (identify) any functional relationship between inputs and outputs if the hidden layer has enough neurons^(5,9). Unfortunately, specifying the (enough) number of hidden neurons isn't an easy matter and still active area of research. So, a trial and error approach should be adopted in order to determine the appropriate number of hidden neurons. It is important to note that if the number of hidden neurons is not enough, the neural network model will fail to capture the dynamics of the plant. On the contrary, when the number of hidden neurons is large, the neural network cause a phenomenon called *overfitting*. So, a trade off should be used to select the appropriate network architecture⁽¹⁰⁾.

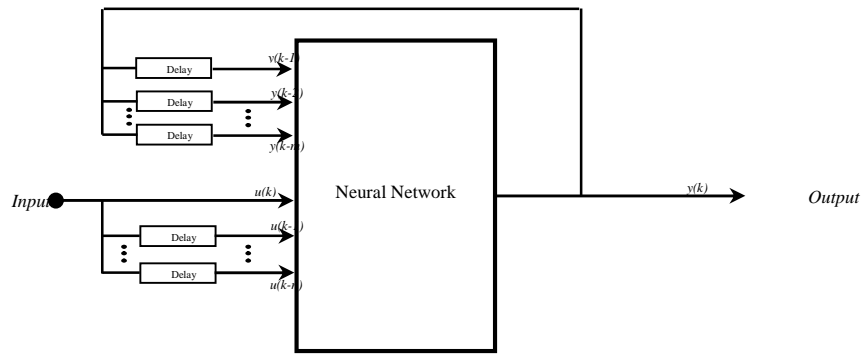

Fig.(6):- Neural Network Identification Model

4- CASE STUDY: DC MOTOR

Although the usage of neural networks is powerful for nonlinear dynamic system identification, In this work, a focus has been done to identify a linear dynamic system in order to facilitate comparison between the responses of the neural networks model and the plant. So, a DC motor have been used as a case study to develop identification model using time-delay neural network. A simple model of a DC motor driving an inertial load gives the angular rate of the load, $\dot{\theta}(t)$, as the output and applied voltage, $v_{app}(t)$, as the input is shown in Figure(7). The differential equations that describe the behavior of the motor are⁽¹¹⁾:-

$$\frac{di}{dt} = -\frac{R}{L}i(t) - \frac{K_b}{L}\dot{\theta}(t) + \frac{1}{L}v_{app}(t) \quad \dots(4)$$

$$\frac{d\dot{\theta}}{dt} = -\frac{K_f}{J}\dot{\theta}(t) + \frac{K_m}{J}i(t) \quad \dots(5)$$

The nominal values for the various parameters of a DC motor are $R= 2$ Ohms, $L= 0.5$ Henry, $K_m = 0.015$ torque constant, $K_b = 0.015$ emf constant, $K_f = 0.2$ Nms, $J=0.02\text{kg.m}^2/\text{s}^2$.

The simulink model for DC motor is shown in Figure (8). This model is used to generate input/output data used to train, test and validate the neural network model.

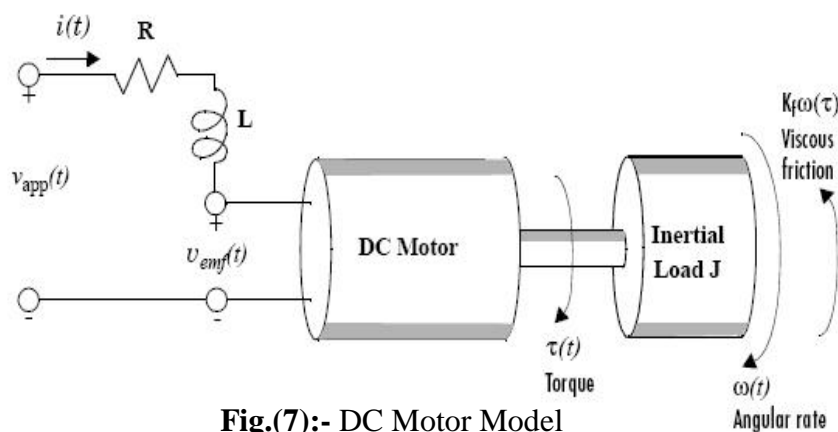

Fig.(7):- DC Motor Model

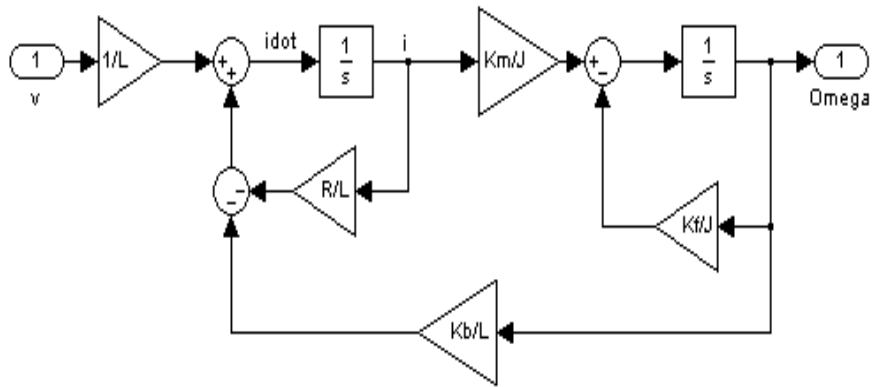

Fig.(8):- Simulink Model of DC Motor

5- RESULTS AND DISCUSSION

A common choice in building the network training set for purpose of identification is to perturb the system (plant) with uniformly distributed white noise signal. This signal should cover the whole dynamic range of the plant and should subsequently be scaled to form the identification network inputs. So, Four thousand input-output data pairs have been generated using the simulink model of DC motor as shown in Figure (9). The data were divided into three sets, 50% for training, 25% for validation, and 25% for testing. Different networks architectures have been simulated in order to pick the most suitable network that emulate the dynamics of DC motor. A network with single input neuron, single output (*purelin*) neuron, and one hidden layer of six (*sigmoid*) neurons with different input/output delays have been trained using Levenberg-Marquardt back propagation training algorithm. Simulation results show that such a network with single input of two time-delay, six hidden neurons, and single output neuron with two feedback time-delay from the output layer to the input layer gives minimum Mean Square Error (MSE) among other architectures as illustrated in Table(1). The selected network architecture is defined in Table(2).

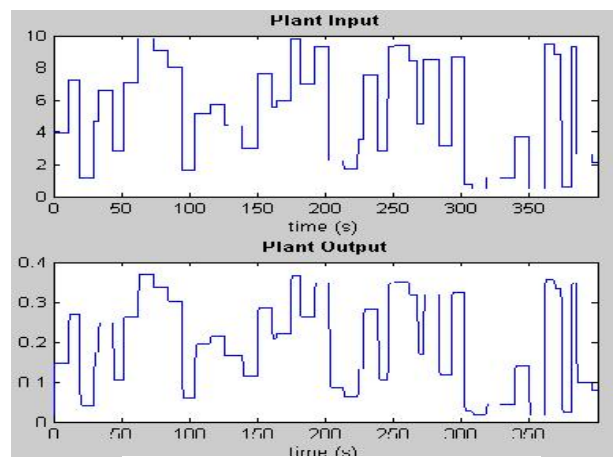

Fig.(9):- Input-Output Data

Table(1):- Network with different Input/Output Delays

No. Input Delay	No. Output Delay	Epochs	Error (MSE)
1	0	13	0.000471
1	1	11	5.5558e-6
1	2	59	4.0378e-7
2	2	136	2.342e-10
2	1	37	1.913e-7

Table(2):- Network architecture

No. of Inputs	1
No. of Delayed Inputs	2
No. of Hidden Layers	1
No. of Hidden neurons	6
No. of Outputs	1
No. of Delayed Outputs	2

Training, validation, testing error of the network is shown in Figure (10), for up to 136 epochs the training error reaches 2.342e-10, this demonstrates the speed of convergence for Levenberg-Marquardt training algorithm which is used for training this neural network model. The input signal, plant (DC Motor) output, NN output, and the error between the NN output and plant output is shown in Figure (11), which show that the response of neural network model to training data is very close to the plant response. The same is true for testing and validation data as shown in Figure (12) and Figure (13) respectively. The response of the network to testing data is very crucial in specifying the goodness of the network, since testing data has never seen by the network during training.

In addition to testing data response, the neural network model has been simulated for Band-Limited White Noise (BLWN) and step input responses as illustrated in simulink models shown in Figure (14). The responses of the neural network model and the DC motor to BLWN and step signals is shown in Figure(15) and Figure(16) respectively. These figures show that the time-delay neural network model emulate the DC motor very well. The weights and biases of the neural network model are shown in Tables(3-5).

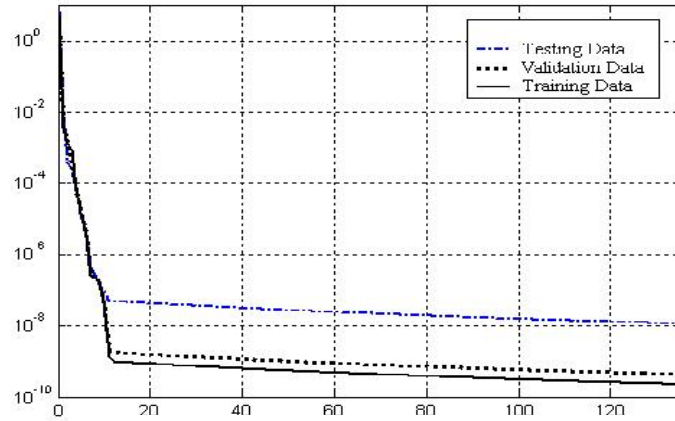

Fig.(10):- Training Error

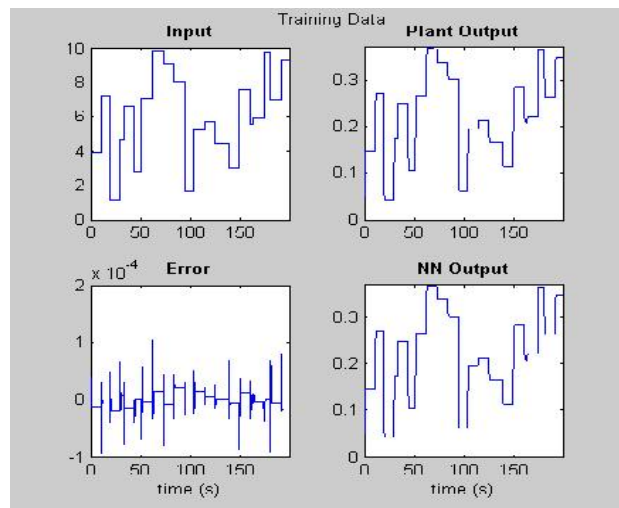

Fig.(11):- Input, plant Output, NN output, and Error For Training Data

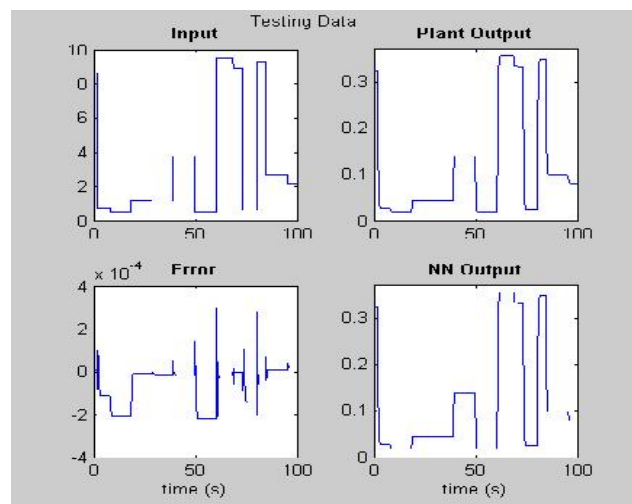

Fig.(12):- Input, plant Output, NN output, and Error For Testing Data

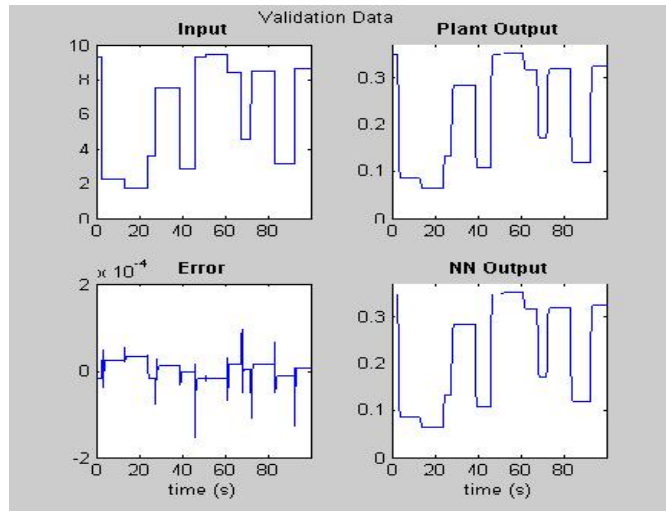

Fig.(13):- Input, plant Output, NN output, and Error For Validation Data

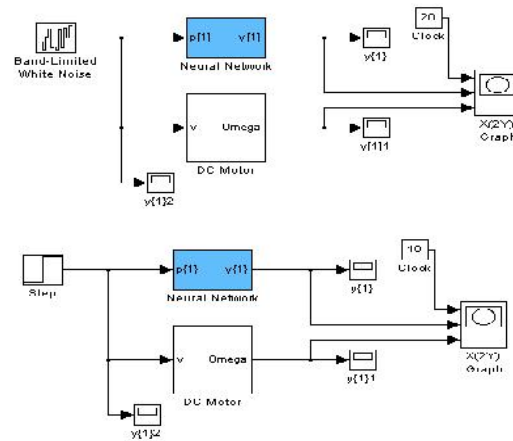

Fig.(14):- Simulink Models for BLWN and Step Input

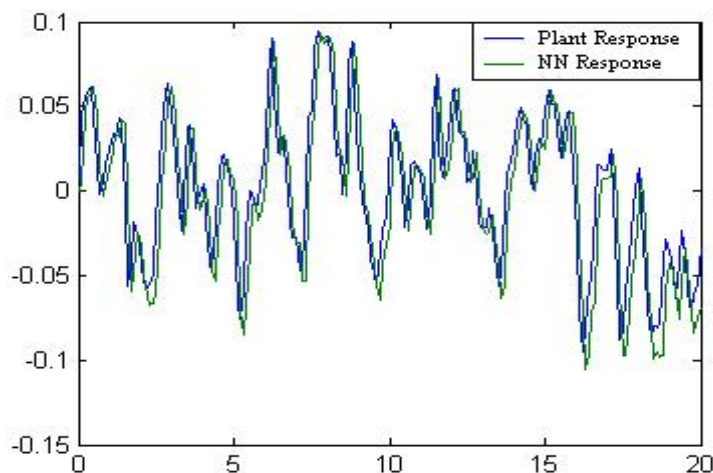

Fig.(15):- NN and Plant responses for BLWN Input

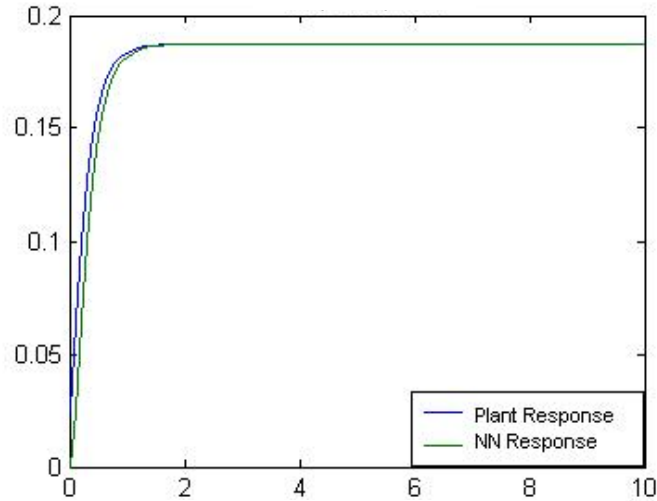

Fig.(16):- NN and Plant responses for Step Input

Table(3):- Input to Hidden Layer Weights and Biases

Hidden Neurons	Input Layer Weights		Hidden Layer Biases
1	0.0260	0.0137	-2.3398
2	-0.1419	0.0139	3.8619
3	0.1241	0.2323	0.7921
4	0.3354	-0.7602	3.8117
5	0.2525	-0.0812	1.0345
6	0.0095	0.0061	-0.0863

Table(4):- Output to Hidden Layer Weights and Biases

Hidden Neurons	Delayed Output	
	1	2
1	5.9032	-1.5092
2	-8.3047	-6.1673
	-3.6912	-8.7153
	5.7413	-9.3308
	-3.8568	-4.5731
	2.0787	-0.4925

Table(5):- Hidden to Output Layer Weights and Biases

Output Neuron	Hidden Neurons						Output Biases
	1	2	3	4	5	6	
1	0.0699	-0.0005	-0.0003	-0.0003	0.0006	0.4863	0.1115

6- CONCLUSIONS

The current appearance of the neural network paradigm as a potent tool for learning complex input-output mappings has motivated many studies to use neural networks models for identification of dynamic systems. So, this work has been applied time- delay neural networks for dynamic system identification. From the results presented, it is apparent that time-delay neural networks can be successfully used for modeling and identification of dynamic systems. DC motor drive has been modeled using time-delay neural networks with Levenberg-Marquardt back propagation training algorithm. It is important to note that there are no clear and hard rules to obtain the optimal network architecture for system identification purposes. So, a trial and error approach should be used to obtain number of hidden neurons as well as the number of delayed inputs/outputs. The performance of the neural network model has been tested for different inputs, so, simulation results proved that neural networks are promising tool for identification of dynamic systems.

7- REFERENCES

1. C.Ping and Q.Lihua, "System Identification in Hydraulic Servo System with Diagonal Recurrent Neural Networks", http://fluid.power.net/techbriefs/hanghzau/5_2_10.pdf.
2. N.S.Nise, " Control System Engineering ", John Wiley & Sons Inc., Fourth Edition, 2004.
3. M.C.Nechyba and Y.Xu, "Neural Network Approach to Control System Identification with Variable Activation Functions", Proceedings of the IEEE International Symposium on Intelligent Control, 16-18 Aug 1994.
4. M.Hagan, H.Demuth, and M.Beale, " Neural Network Design ", PWS Publishing, Boston, 1996.
5. H.B.Demuth and M.Beala, " Neural Network Toolbox a: User's Guide", Ver. 3, The Mathworks, Inc., Natick, MA, 1998.
6. M.Hagan and H.Demuth, " Neural Networks for Control ", Proceedings of the American Control Conference, San Diego, 1999.

7. P.Q.Dzung and L.M.Phuong," ANN- Control System DC Motor ",
<http://www.glib.hcmuns.edu.vn/gsd/collect/hnkhbk/index/assoc/HASH0188.dir/doc.pdf>
8. M.Norgaard, O.Ravn, N.K.Poulsen and L.K.Hansen, "Neural Networks for Modelling and Control of Dynamic Systems", Springer Verlag, 2000.
9. C.F.Wong, J.Shippen and B.Jones, " Neural Network Control Strategies for low specification servo actuators ", International Journal of Machine Tools & Manufacture, 38, 1109-1124, 1998.
10. M.S.Ashhab, " Inverse Control Based on Neural Net Models: Application to the Breathing Process in Internal Combustion Engines",2004.
11. "Control System Toolbox For Use with MATLAB" The Mathworks,2006.

تعريف الأنظمة الحركية باستخدام الشبكات العصبية الأمامية ذات التأخير الزمني: تطبيقها

على محرك التيار المستمر

علي خضير مطلق

مدرس مساعد

كلية الهندسة جامعة ديالى

الخلاصة

إن قدرة الشبكات العصبية الأمامية المتعددة الطبقات على التقريب العام للدوال جعلها خيار شائع لنمذجة الأنظمة الحركية. في هذا البحث، نمذجة الأنظمة الحركية باستخدام الشبكات العصبية الأمامية ذات التأخير الزمني تمت دراستها وعرضها مع تطبيقها على محرك DC كحالة دراسة. نموذج الشبكة العصبية الذي تم تصميمه في هذا البحث مؤلف من ثلاث طبقات حيث إن الطبقة الخفية تمتلك دالة لا خطية (sigmoid) و طبقة الإخراج لها دالة خطية مع وجود تأخير بين طبقة الإدخال والإخراج. نتائج المحاكاة بينت أن الشبكات العصبية أداة يمكن الاعتماد عليها في نمذجة الأنظمة الحركية. كلمات دالة: تعريف النظام ، شبكات عصبية ، محرك التيار المستمر.