STUDY THE CREEP OF TUBULAR SHAPED FIBER REINFORCED COMPOSITES

Dr. Najat j. Salah

Dr. Adnan A. Abdul Razak

Assistant Prof.

Lecturer

Chem Eng. Dept.

University of Technology

Hussein Ali Hamid AL-Abdly

Hassen Sh. Majdi

Ministry of Science and Technology

ABSTRACT

In present work tubular –shaped fiber reinforced composites were manufactured by using two types of resins (Epoxy and unsaturated polyester) and separately reinforced with glass, carbon and kevlar-49 fibers (filament and woven roving), hybrid reinforcement composites of these fibers were also prepared. The fibers were wet wound on a mandrel using a purposely designed winding machine, developed by modifying an ordinary lathe, in winding angle of 55° for filament. A creep test was made of either the full tube or specimens taken from it. Creep was found to increase upon reinforcement in accordance to the rule of mixture and mainly decided by the type of single or hybridized fibers. The creep behavior, showed that the observed strain tends to appear much faster at higher temperature as compared with that exhibited at room temperate. The creep rate also found to be depending on fiber type, matrix type, and the fiber /matrix bonding. The creep energy calculated from experimental observations was found to exhibit highest value for hybridized reinforcement.

KEYWORDS

Creep, tubular shaped, composites

NOMENCLATURES

A	Cross section area of specimen (m^2).
F	Force exerted on specimen in (N).
m	The mass of load Hung in specimen (kg).
n	Stress exponent
Q	Activation energy for creep (KJ. mol)
R	Universal gas constant, j/mol K
T	Temperature, °K
	Greek Letters
ϵ_{ss}	strain rate
σ	stress

INTRODUCTION

Composites are combination of two or more materials present as separate phases and combined to form desired structures so as to take advantage of certain desirable properties of each component. The constituents can be in the form of particles, rods, fibers, plates, foams, etc.

The fibers are usually wetted before winding either as individual strands or as tows, and first fed through a resin bath and then continuously wound on to a mandrel. After the appropriate numbers of layers have been applied, curing is carried out in an oven or room temperature, after which the mandrel is removed.

Various winding patterns are possible (i.e. circumferential, helical, and polar), to give the desired mechanical characteristics ^[1]. Fig (1) represents the helical, circumferential, and pot on filament winding techniques. Common filament- wound structures include rocket motor casings, rocket launchers, storage tanks, pipes, and pressure vessels.

Ericken ^[2] studied the creep of Kevlar [49]/epoxy composites at room temperature and the results were compared with creep behavior of individual fibers and unreinforced epoxy, and concluded that composites exhibit transient creep throughout the 1000 hr tests; no steady state creep was observed. The shape of composite creep curves varied with stress, the changes were related to the creep behavior of fibers and matrix individually under condition of strain comparable to those of matrix. At low stresses the matrix initially creeps at a slower rate than the fibers, whereas at higher stresses the reverse situation exists. Irion and Adams ^[3] described and evaluated two new creep fixtures, one loads a specimen along the side, whereas the other

provides side support to a specimen and allows end loading. Deya^[4] studied the effect of moisture and stress on creep behavior of unsaturated polyester and its composites, and found that water absorption increased the creep rate.

The main purpose of the present work was to develop some fiber reinforced polymer tubular composites, the work would be include the preparation of different matrix (EP and UP) composites. Various reinforcements are to be tested single type fibers (glass, carbon, Kevlar) and hybridized fibers were to be investigated. Creep test is performed and their dependence on temperature to be studied.

THEORY

Creep is the deformation that occurs over a period of time. All materials creep under load at all temperatures, but a very wide range of creep behavior is revealed when comparisons are made in terms of the three important parameters that describe the creep process namely, stress, temperatures and time.^[5]

Creep behavior is described by the conventional creep curve Fig (2), made up of three successive stages, viz: primary (or transient),

secondary (or steady state) and tertiary. An engineering part should spend the majority of its service life in the steady-state range of creep since once the tertiary stage is entered the creep strain accelerates rapidly to fracture.^[6] The strain rate during the steady-state regime is often described as follows:

$$\dot{\epsilon}_{ss} = A \sigma^n \exp\left(\frac{-Q}{RT}\right) \quad (1)$$

Where: $\dot{\epsilon}_{ss}$ = strain rate, T = temperature (°k), σ = stress, A = constant, n = stress exponent (3-8), Q = activation energy for creep.

The creep rate can be obtained by using equation.

$$t_r = A \exp\left(\frac{Q}{RT}\right) \quad (2)$$

EXPERIMENTAL WORK

1- Materials

The materials used in the present work as a matrix were: Epoxy resin and unsaturated polyester resin and the material used as reinforcements were fiber glass (type E), Kevlar-49 fiber, and carbon fiber (HS).

The resin used in present work was Epoxy (Cy- 223), its density was (1.3-1.4) g/cm³ and Mwt = 380. g/g mole, The hardener used was HY 956 (Diethylene tri amine), it is liquid, with a

density is ranging from (1.15-1.25) gm/cm³, it was added to the resin, thus the chemical bonding and cross linking was formed with the epoxy resin.

The density of unsaturated polyester used in present work was (1.19- 1.5) gm/Cm³. The hardener used with UP was methyl Ethyl ketone peroxide (MEKP) and activated cobalt Octate 6% as accelerator, and they were used in weight percentage of :MEKP (1.5-3%), Activated Cobalt Octate 6% (0.2-0.5%)

2 Reinforcement Materials

2.1 Fiber Glass

In the present work "E" glass was used, it has good strength, stiffness, electrical and weathering properties. Its chemical composition is shown in the following table, and it was used as continuous filament.

2.2 Kevlar fibers

In the present work woven roving Kevlar- 49 (0°-45°) was used and its surface density was (340g/m²).

2.3 Carbon Fiber

HST carbon fiber was used as woven roving (0°-90°), and its surface density was 225g/m².

3 -Experimental Apparatus

Experimental apparatus consists of the followings:

3.1 Resin Bath

It is a tank equipped with thermostat electrical heater; it was used for the preparation of the resin. A mixer of helical ribbon type with 1500 rpm was used for a continuous mixing of the viscous liquid, the specifications of this mixer were: RPM is 1500 (750 rpm used), type is helical ribbon. Resin bath and mixer are shown in Fig (3).

3.2 Mandrel

There are several factors affecting the selection of mandrel materials. These factors include the number and size of the moldings to be produced, the type and finishing requirements of the products as well as the molding process itself. The mandrel used during the course of this work was fabricated from low carbon steel coated with a thin layer of nickel chrome to give the required impact resistance, strength, smooth and shiny surface. The dimensions of mandrel was L= 160 Cm and D_o = 16 Cm.

4 -Winding Machine

Filament winding was used to fabricate the structural cylindrical samples, based on polymer matrix- fibrous composite; these samples were fabricated using a modified winding machine shown in fig (4). The fabrication steps were as follows:

4.1 Preparation of Mandrel

The mandrel was coated with a thin homogenous layer of honey wax for 15 minutes, then it was polished with a dry piece of cloth, after that the mandrel was sprayed with PVA solution three times at interval of 15 minutes.

4.2 Winding Process

After the preparation of the resin with the specification mentioned in section (3.1), by using the resin bath, the winding process was carried out using the winding machine as follows:

The fiber is usually wetted before winding and laid down under tension, then impregnation or soaking of the filaments, woven fabrics (tapes) was carried out by passing them through the resin bath at low speed and at constant rate to ensure sufficient saturation of fibrous with the resin. After leaving the resin bath the reinforced fiber were passed over tensioning devices; to keep the required tension; after which the fibers were wound onto the mandrel a part- layer after layer with preset tension. The mandrel can make one or two rotational movements and with a thread guide, an inverted translational or rotational movement, this permits to control the reinforcement laying scheme

both within one and the same layer and through the thickness of article, by varying the angle of filament or tape placement.

The winding angle ($55^{\circ} \pm 2^{\circ}$) was determined by the relative speeds of the lateral movement of the traverse and rotation of the mandrel and the diameter of the mandrel. The samples were kept in the mandrel for 48 hrs before they were drawn from the mandrel. The winding process is shown schematically in Fig (4)

5- Preparation of Samples

The following samples were prepared:

5.1 Resin with One Type of Fiber

Samples with single fiber were used with volume fractions of 50% as follows:

- Epoxy } + glass fiber (four layer)
- UP } }
- Epoxy } + Kevlar fiber -49 (four layer)
- UP } }

5.2 Hybrid Samples

Samples with more than one fiber were used with volume fractions of 50% as follows:

- Epoxy } + Kevlar-49 (two layer) + Carbon (two layer)
- UP } }
- Epoxy } + glass fiber (two layer) + Kevlar -49 (two layer)
- UP } }
- Epoxy } + Fiber glass (two layer) + Kevlar (One layer) + Carbon (One layer)
- UP } }

The following diagram illustrates the possibilities of having more than one hybrid compound:

6- Evaluation of Composites

6.1 Creep Test

Creep tester type (SM106MK11TQ) was used as shown in fig. (6a), the sample dimensions were as shown in fig. (6b). Creep is studied by subjecting a sample rapidly to a constant load or constant stress and observing the resulting time- dependent strain for long periods of time frequently for a week or more. The weight or load exerted on the specimen to keep the stress constant was determined by using the following relation:

$$\sigma = \frac{F}{A} = \frac{(2.96 + 8m) \times 9.81}{A} \quad (3)$$

The test was carried out in different temperatures of (25, 40, 70) °C.

Creep energy refer to as activation energy of molecules and later refer to extent of change in substance molecule from ground state to excited state which affected by thermal, mechanical and chemical behavior, from table (4) the values of creep energy for UP composites samples range between (13.02) Kj.mol for (UP+G) and (16.12) Kj.mol for (UP+G+K+C), and for EP composites samples range between

(9.79)Kj.mol for (EP+G) and (12.2)Kj.mol for (EP+G+K+C).

CONCLUSIONS

Highest creep strain was observed in glass fiber reinforcement at (R. T) moreover, higher temperatures yielded even higher creep rates.

REFERENCES

1. R. G. Weatherhead, "FRP Technology, Fiber Reinforced Resin System" Applied Science Pub. LTD, London (1980).
2. R. H. Ericken, "Composite", July (1976).
3. M. N. Irion & D. F. Adams. "Composite" April, (1981).
4. B. M. Deya, "Engineering & Technology" 19, 2, (2000).
5. V. H. Shah, "Hand book of Plastic Testing" Society of Plastic Engineering, (1983).
6. F. A. Crane & J. A. Charles, "Selection & Use of Engineering Materials, Butterworth Co (Publishers) Ltd, (1987).
7. N. G. McGrum et al "Principles of Polymer Engineering" 2nd Edit, John Wiley & Sons, New York, (1997).
8. R. K. Jain & S. K. Goswaamy "Composite" 10, 1, Jan. (1979).

9. Ali hobie “Improved the properties of fiber reinforced plastic material “Msc University of Technology, material department (1999)
10. A. S. Wood, “Hybrid reinforcement, Low Cost rate to premium performance, Modern plastic” 55, 3, March, (1978).

Table (1) Chemical composition of glass fiber

SiO ₂	Al ₂ O ₃	CaO	MgO	Na ₂ O, K ₂ O	Ba ₂ O ₂
52.4	14.4	17.2	4.6	0.8	10.6

Table (2) Values of creep rate (1/k. min) for Epoxy and unsaturated polyester composites.

Samples	Creep rate	Samples	Creep rate
UP+ G	1.3	EP+ G	7.25
UP+ K	1.68	EP+ K	4.5
UP+ K+ C	0.65	EP+ K+ C	2.87
UP+G+ K	2.17	EP+ G+ K	5.59
UP+ G+ K+ C	0.97	EP+ G+ K+ C	4.02

Table (3) Values of creep constant for epoxy and unsaturated polyester composites

Samples	Creep constant		
	25C°	40C°	70C°
UP+ G	5.11	2.39	1.57
UP+ K	5.21	2.28	1.78
UP+ K+ C	5.04	2.7	2.19
UP+ G+ K	5.13	2.16	1.82
UP+G+ K+ C	4.99	2.51	1.85
EP+G	5	1.64	1.35
EP+ K	5.17	1.84	1.48
EP+ K+ C	5.26	2.04	1.72
EP+ G+ K	5.22	1.75	1.37
EP+ G+ K+ C	5.2	1.9	1.57

Table (4) Values of creep Activation energy (Q) (KJ. mol) for epoxy and unsaturated polyester composites

Samples	Q (KJ. mol)	
	UP	EP
+ G	13.02	9.79
+ K	14.62	11.04
+ K + C	15.1	11.38
+ G + K	13.62	10.47
+ G + K + C	16.12	12.2

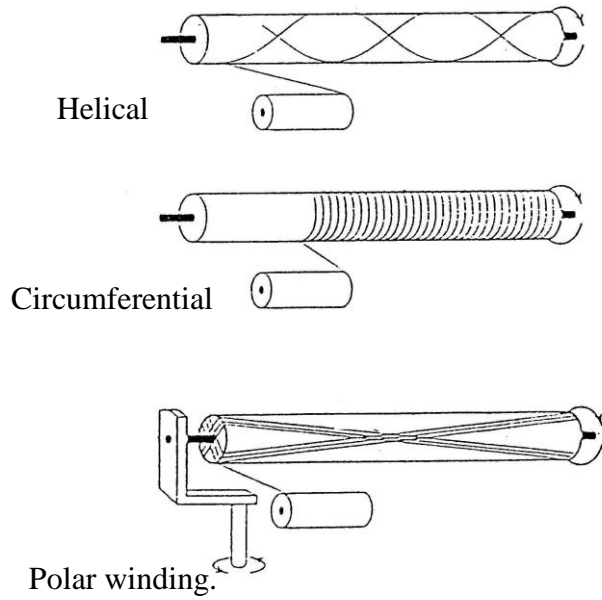

Fig. (1) Schematic representation of helical, circumferential and polar filament winding technique. [3]

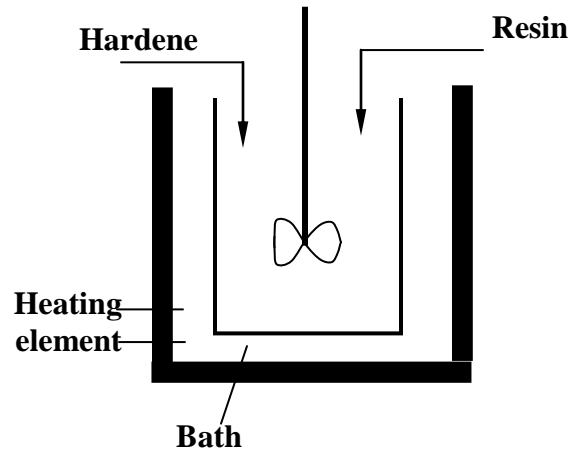

Fig. (3) Resin Bath

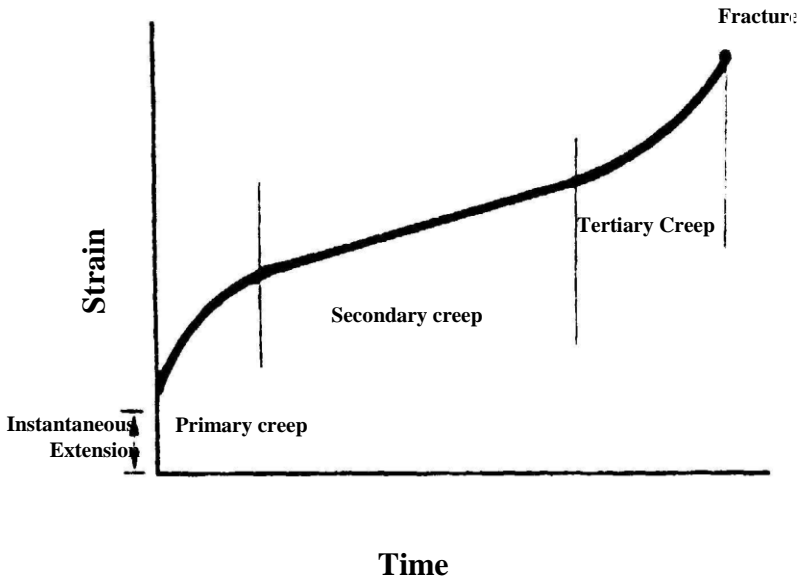

Fig. (2) Conventional creep curve, showing the stages of creep [5]

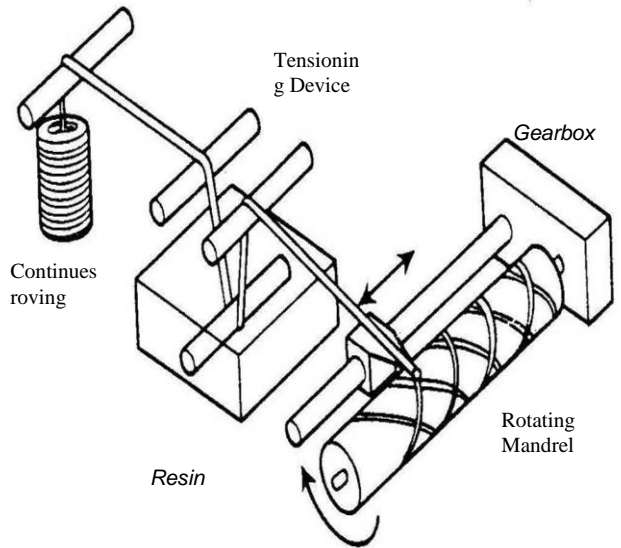

Fig.(4) Schematic of Modified Winding Machine

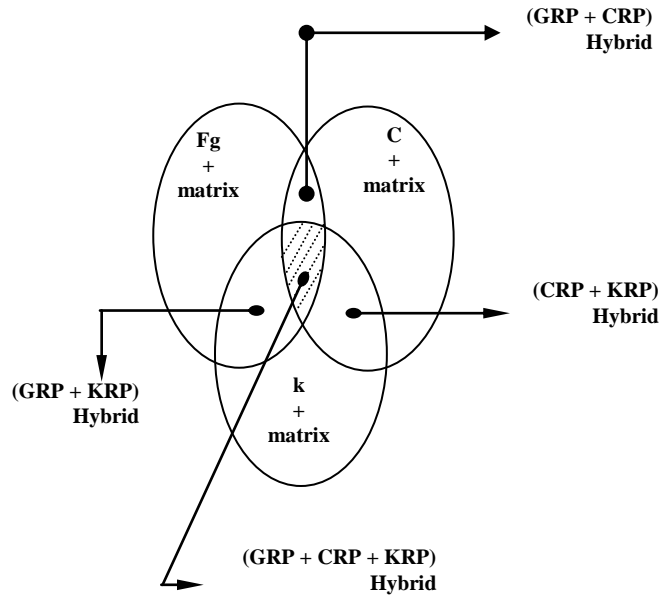

Fig. (5) Schematic shown the possibility of making hybrid composites

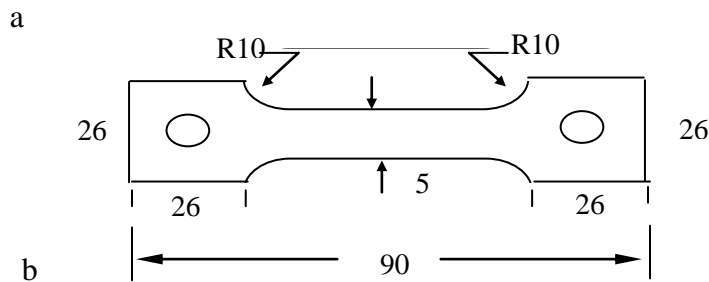
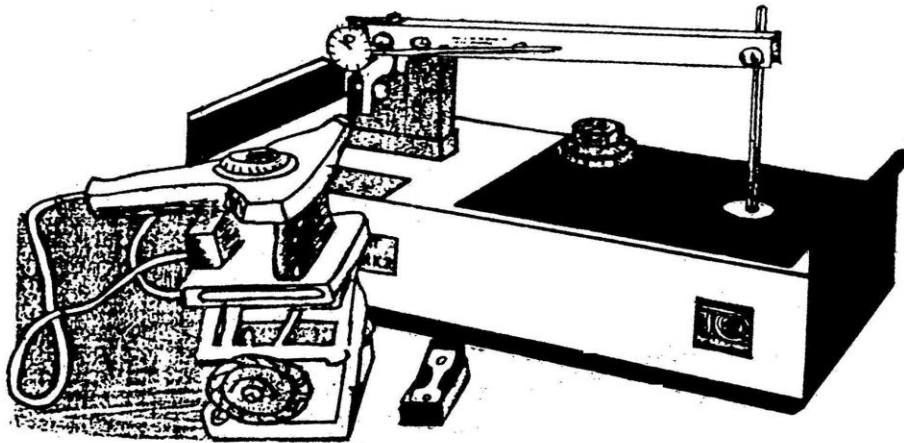

Fig. (6) Creep Test a-Creep tester, .a-Creep tester, b-samples used in creep test.

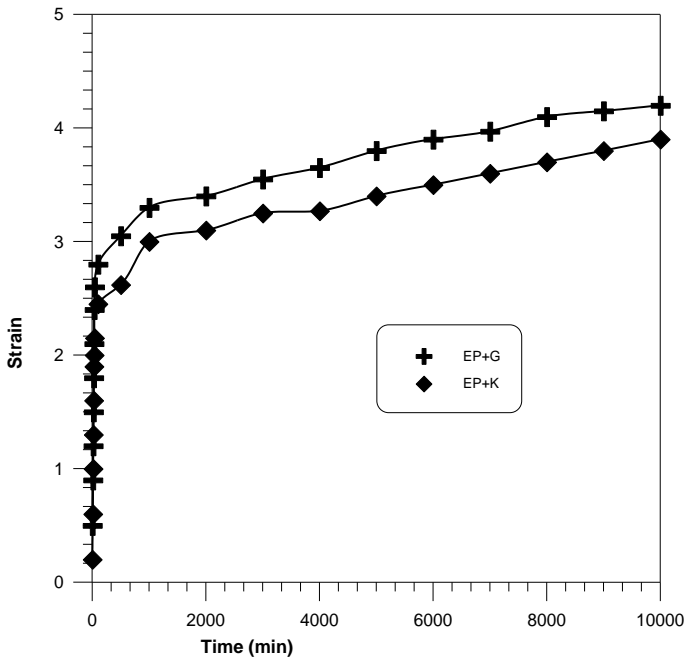

Fig (7) the variation of creep strain with time for EP composites (T = 25°C, single)

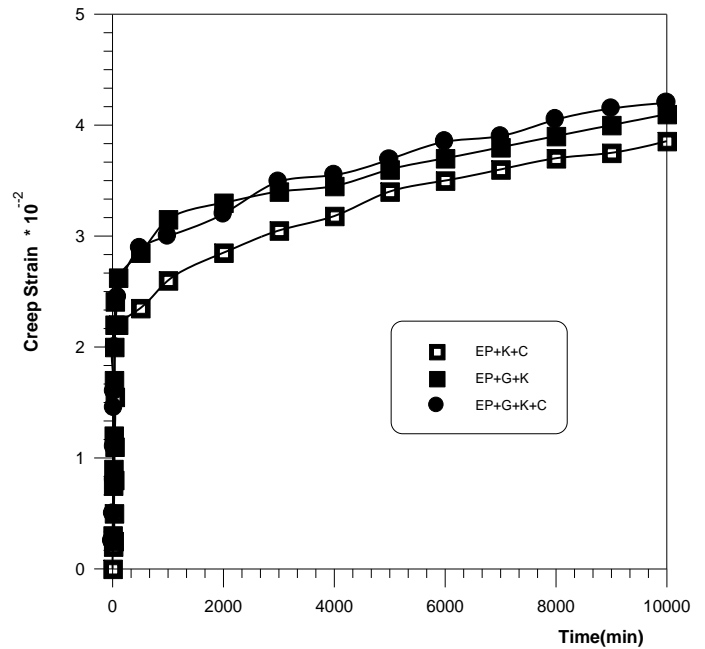

Fig (8) the variation of creep strain with time for EP composites (T = 25°C, hybrid)

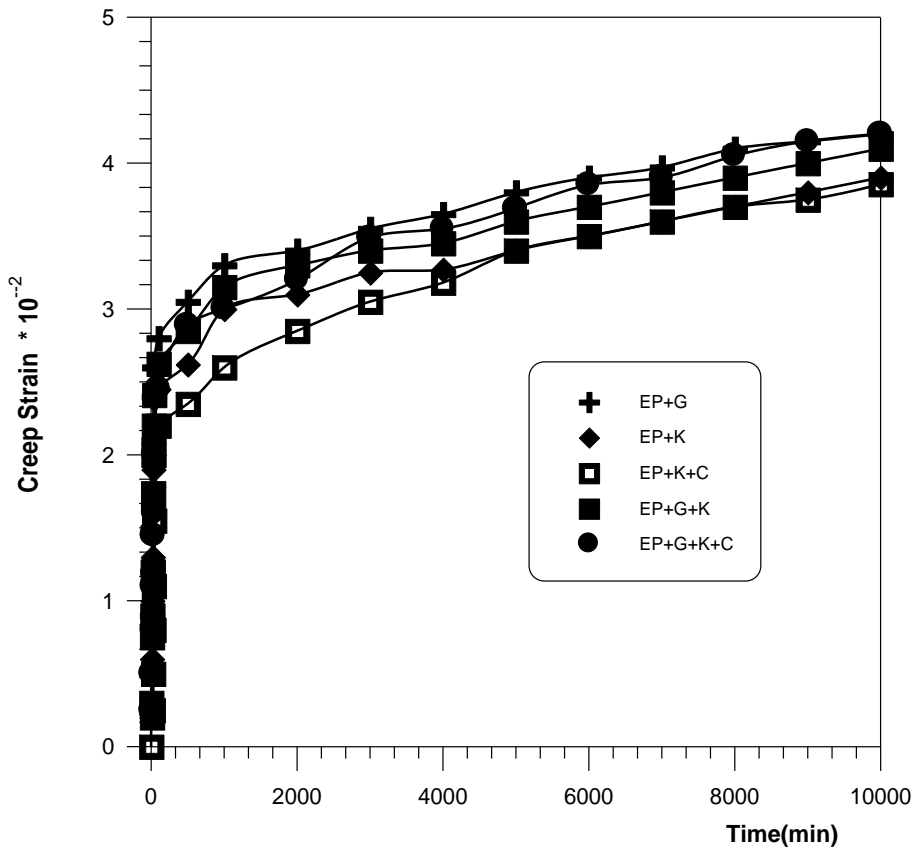

Fig (9) the variation of creep strain with time for EP composites (T = 25°C, single, hybrid)

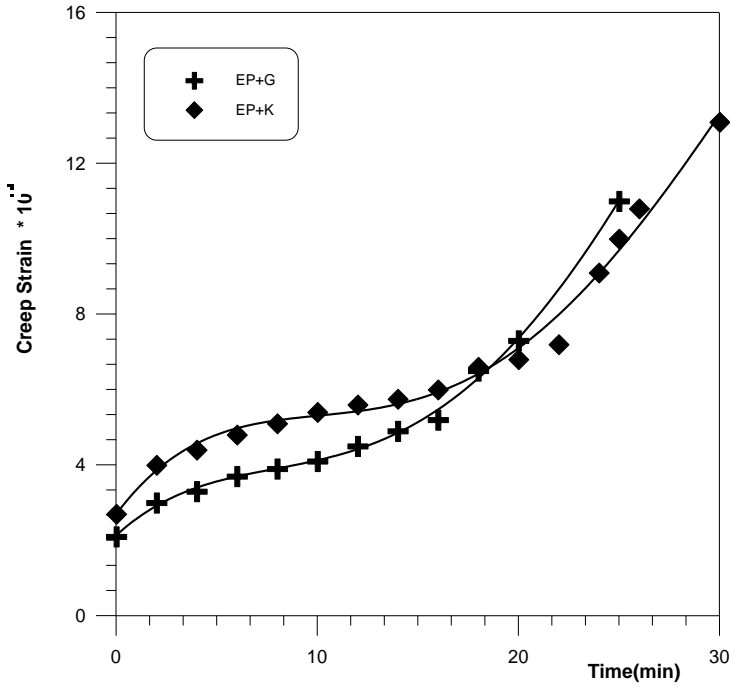

Fig (10) the variation of creep strain with time for EP composites (T = 40°C, single)

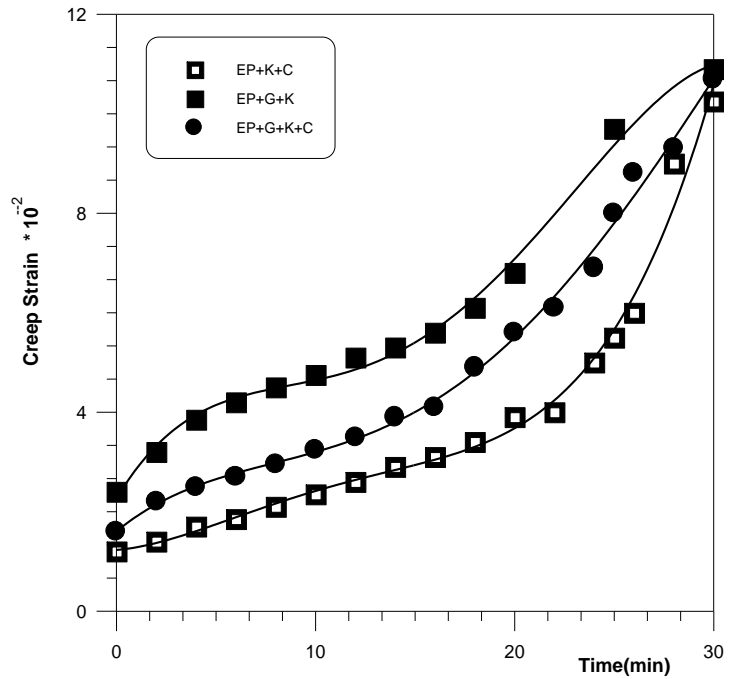

Fig (11) the variation of creep strain with time for EP composites (T = 40°C, hybrid)

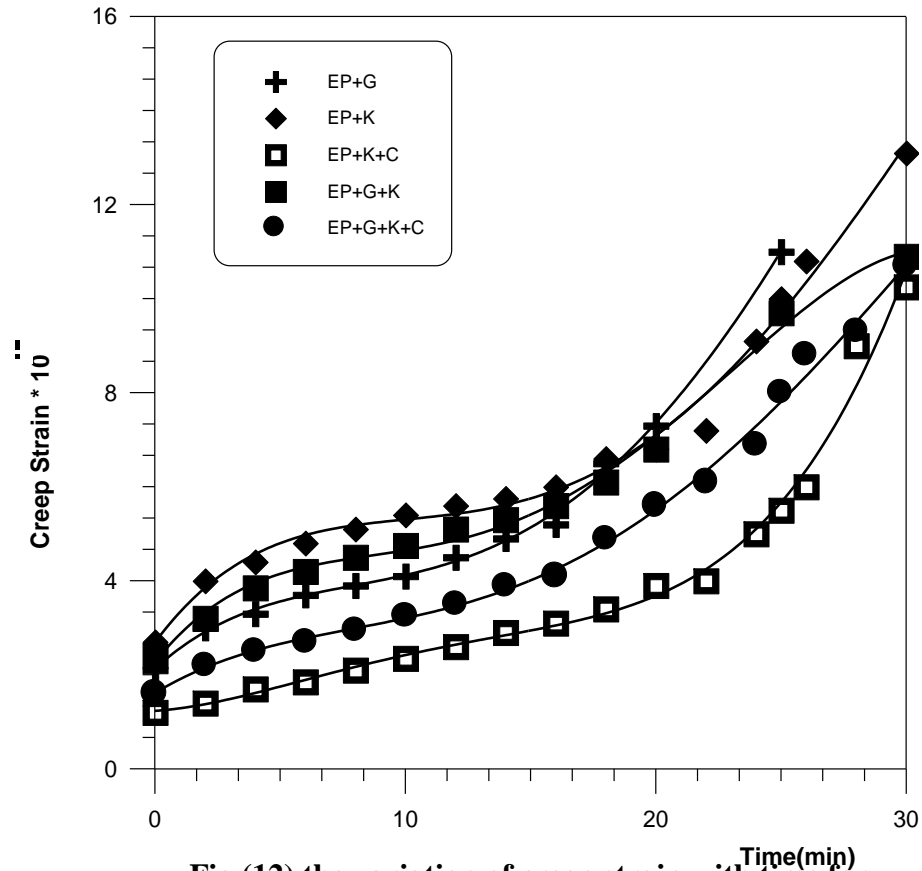

Fig (12) the variation of creep strain with time for EP composites (T = 40°C, single, hybrid)

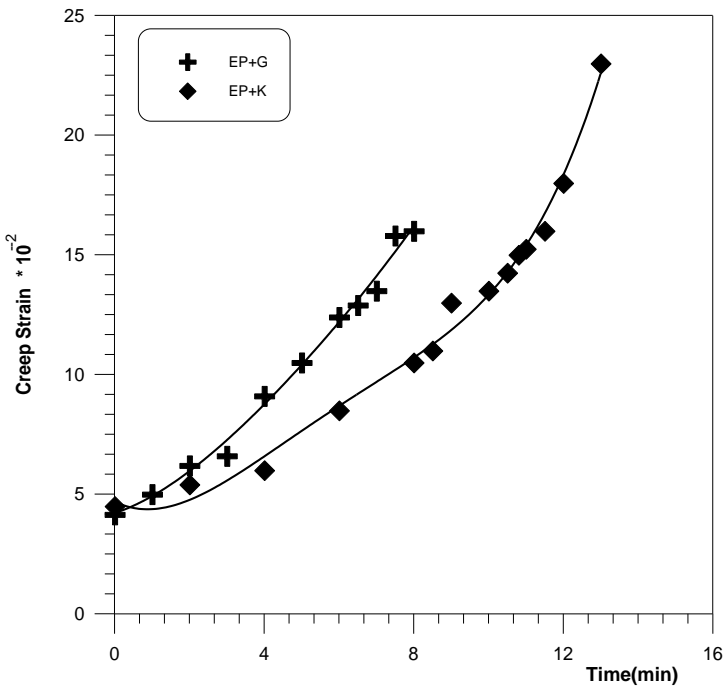

Fig (13) the variation of creep strain with time for EP composites (T = 70°C, single, hybrid)

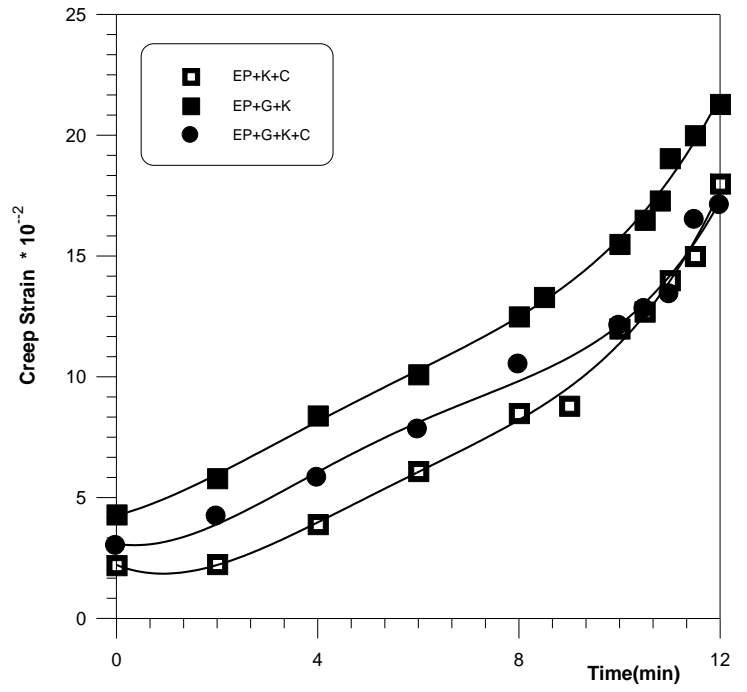

Fig (14) the variation of creep strain with time for EP composites (T = 70°C, hybrid)

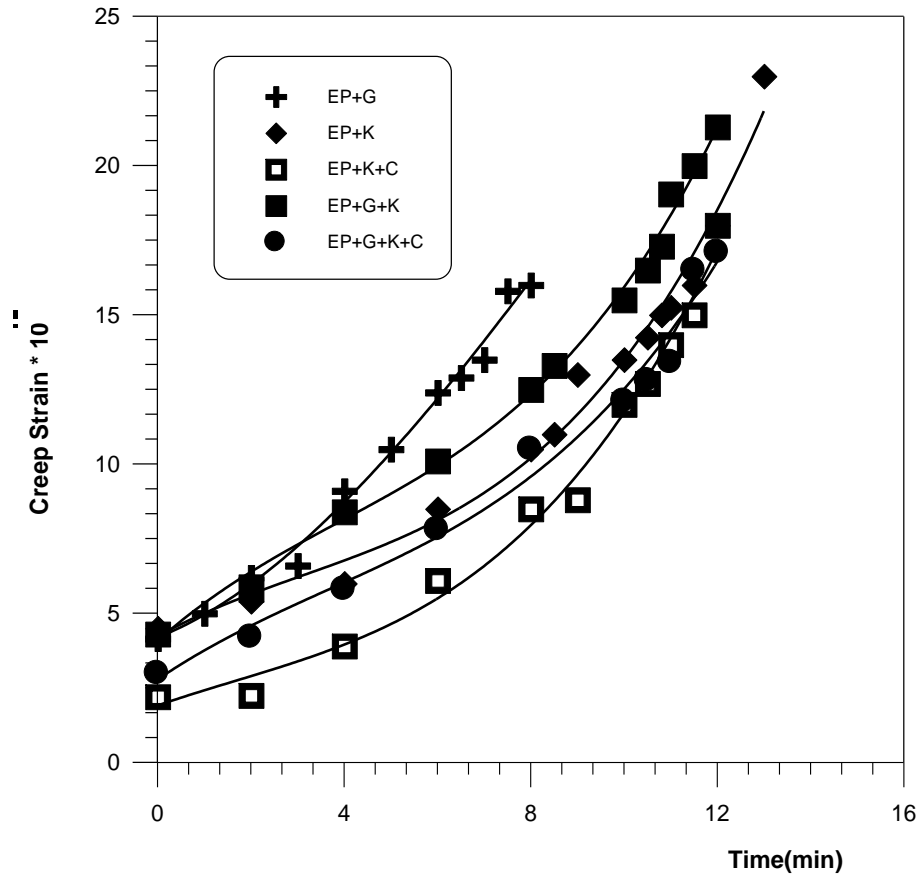

Fig (15) the variation of creep strain with time for EP composites (T = 70°C, single, hybrid)

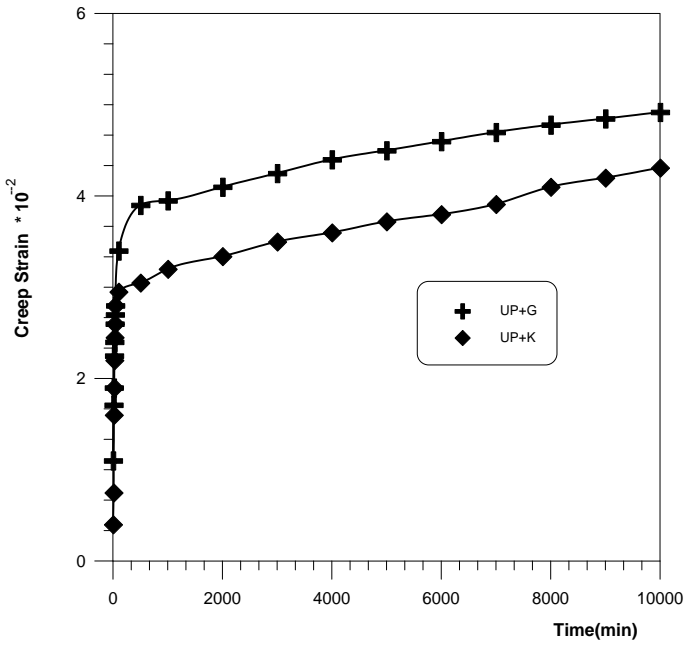

Fig (16) the variation of creep strain with time for UP composites (T = 25°C, single)

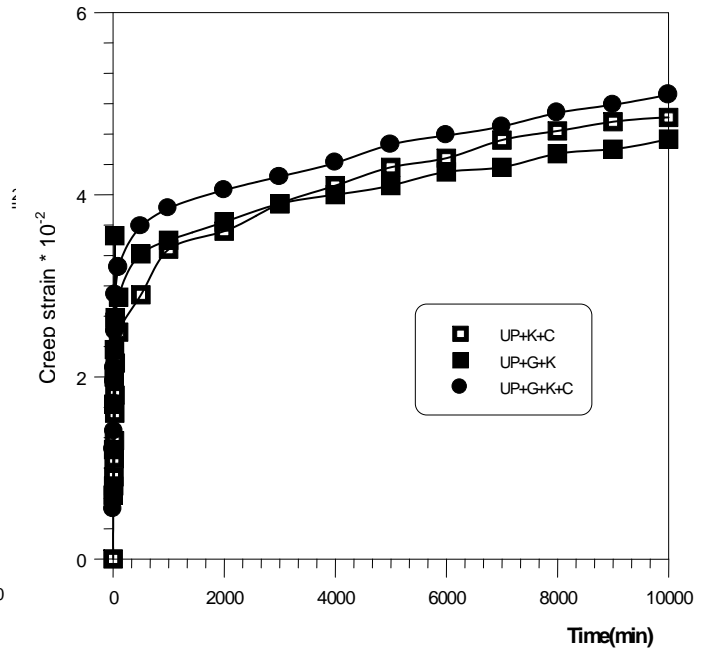

Fig (17) the variation of creep strain with time for UP composites (T = 25°C, hybrid)

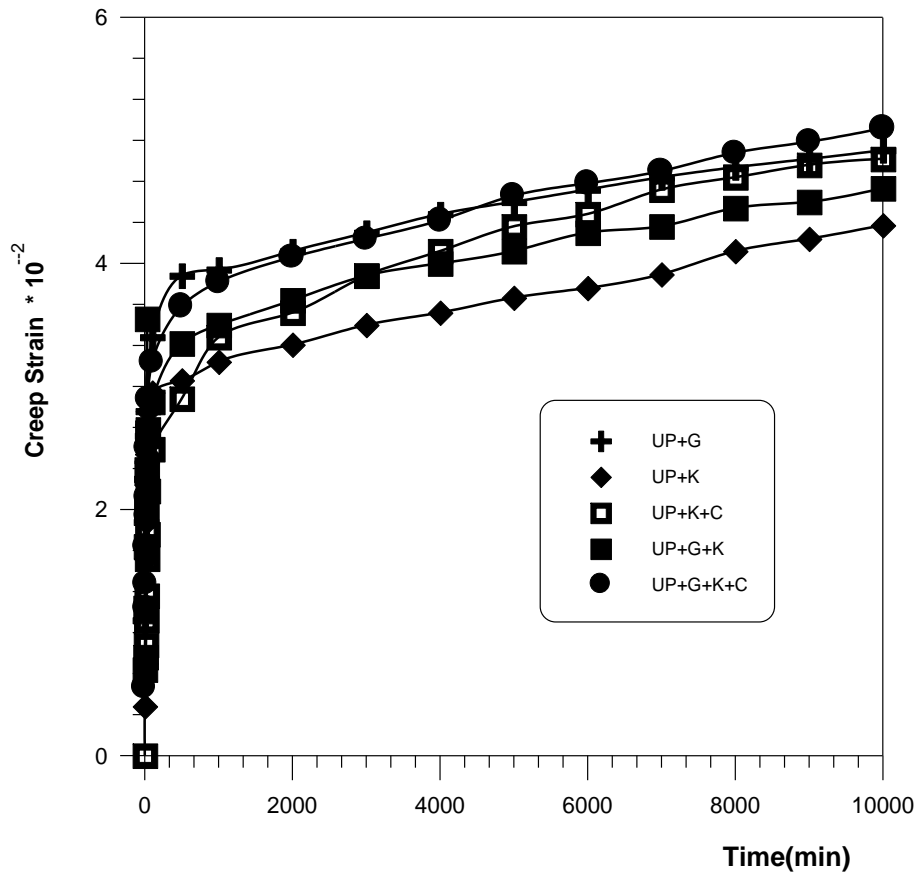

Fig (18) the variation of creep strain with time for UP composites (T = 25°C, single, hybrid)

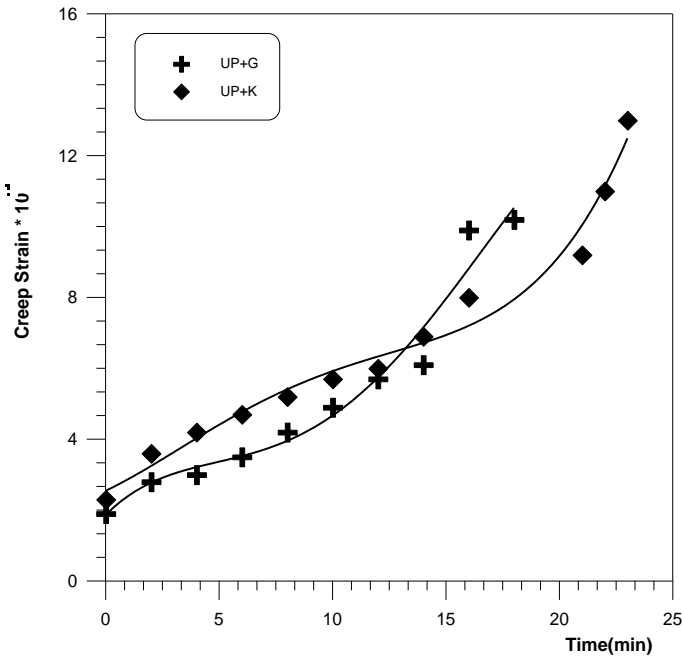

Fig (19) the variation of creep strain with time for UP composites (T = 40°C, single)

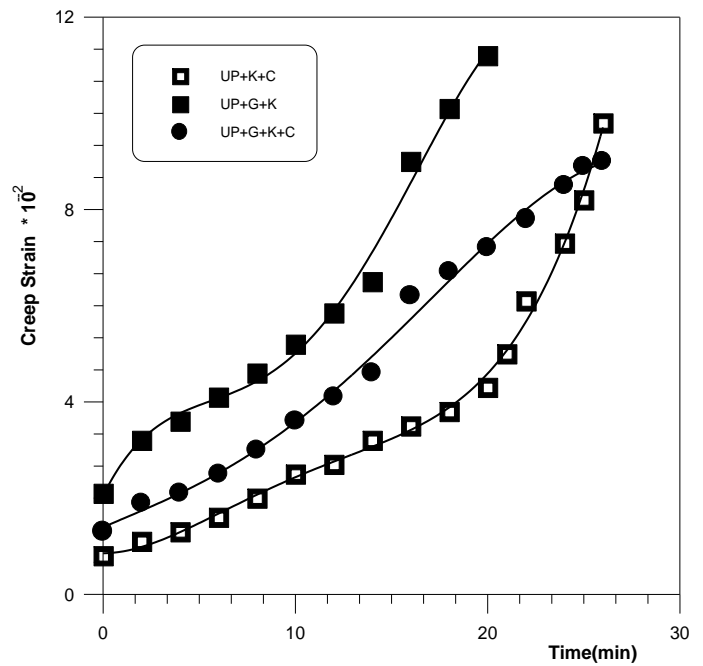

Fig (20) the variation of creep strain with time for UP composites (T = 40°C, hybrid)

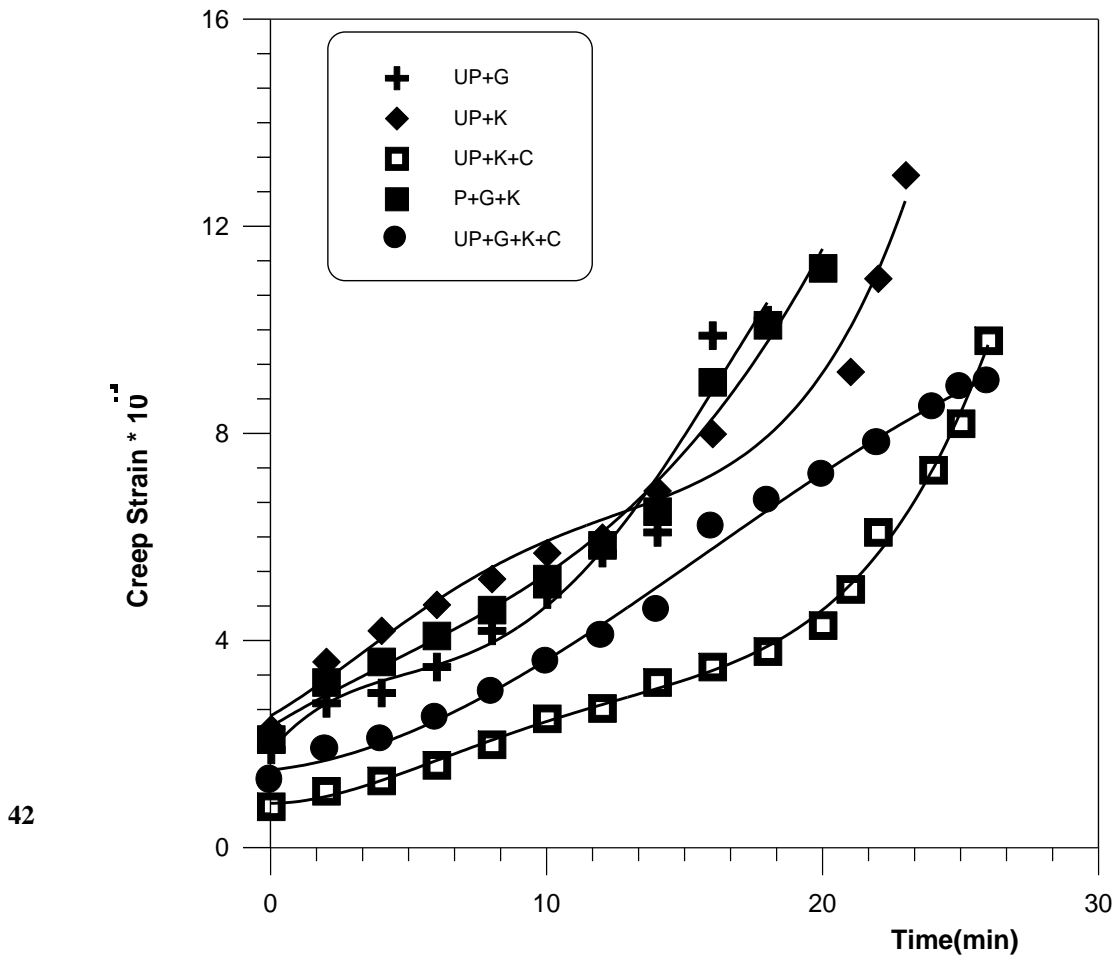

Fig (21) the variation of creep strain with time for UP composites (T = 40°C, single, hybrid)

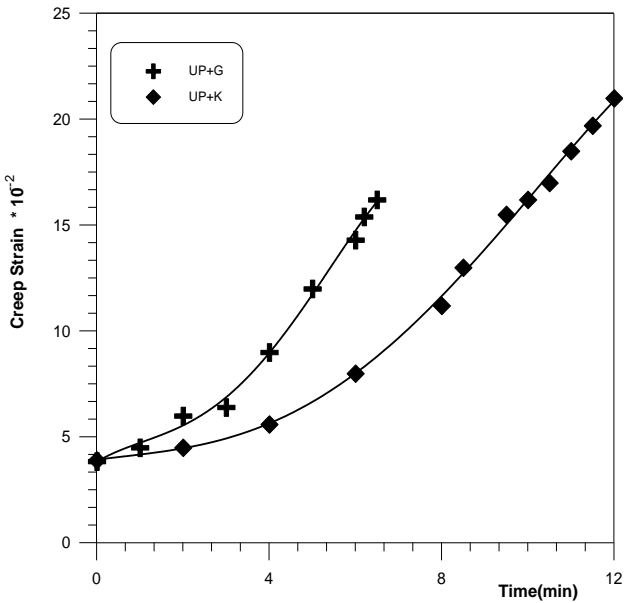

Fig (22) the variation of creep strain with time for UP composites (T = 70°C, single)

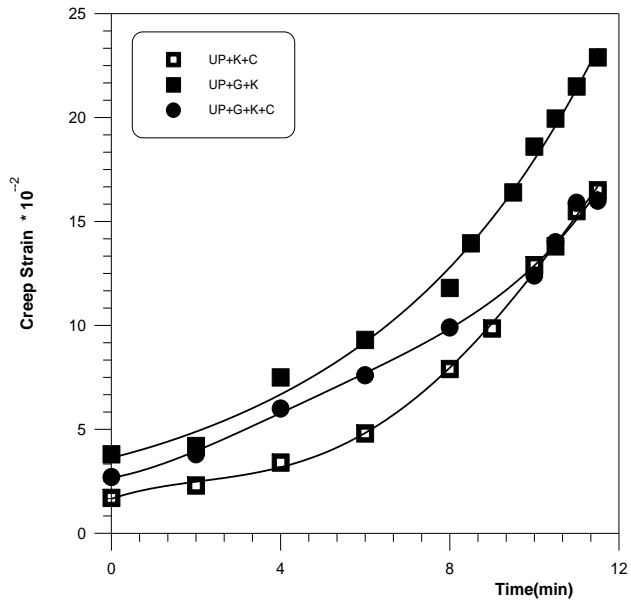

Fig (23) the variation of creep strain with time for EP composites (T =70°C, hybrid)

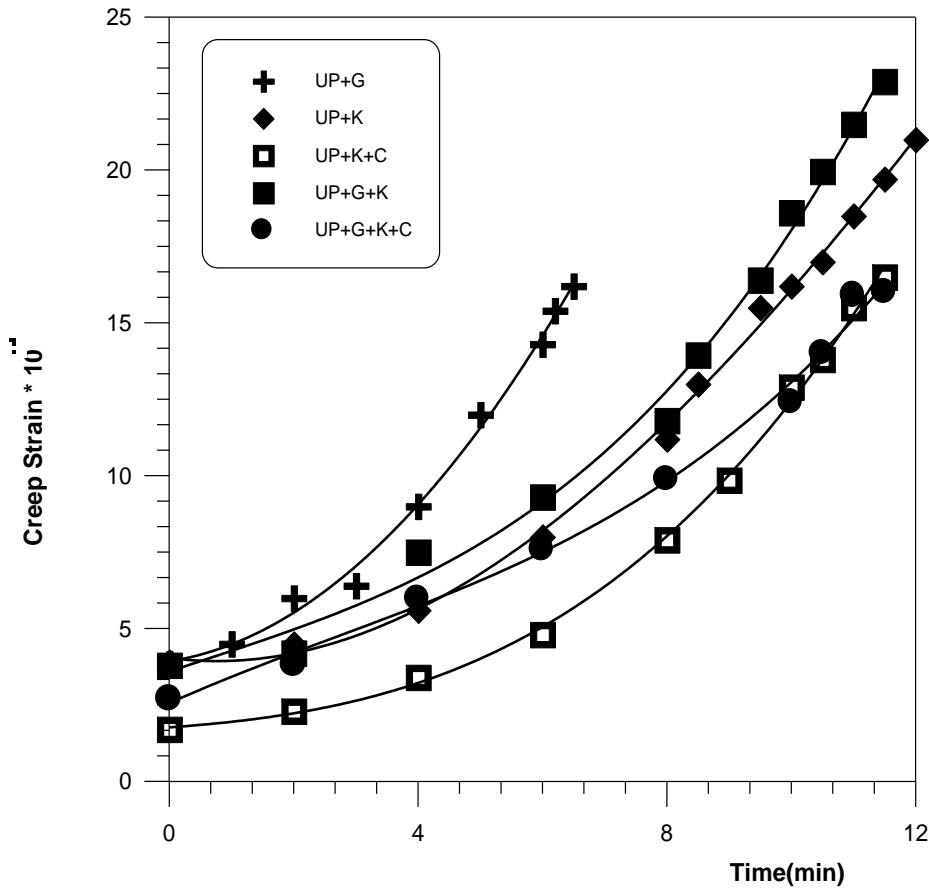

Fig (24) the variation of creep strain with time for UP composites (T = 70°C, single, hybrid)

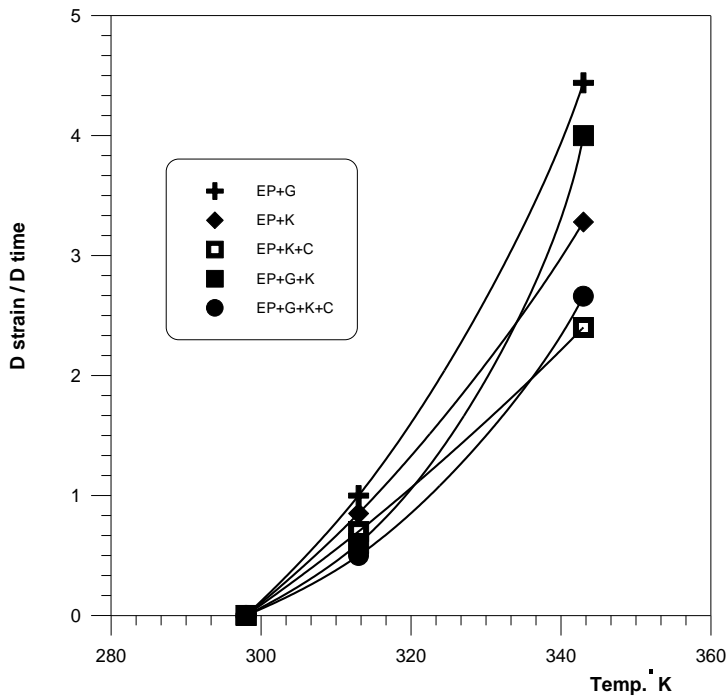

Fig (25) D strain / D time versus Temperature plot for EP composites

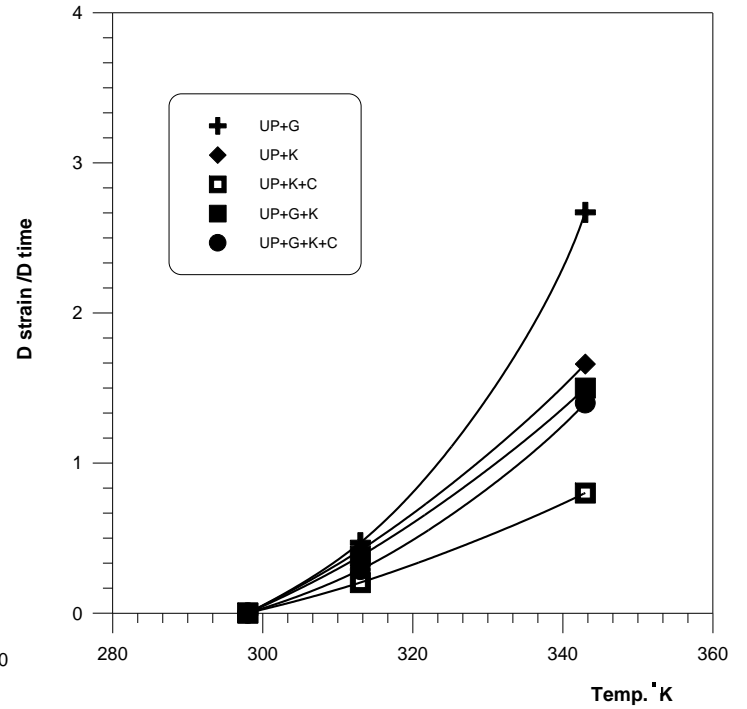
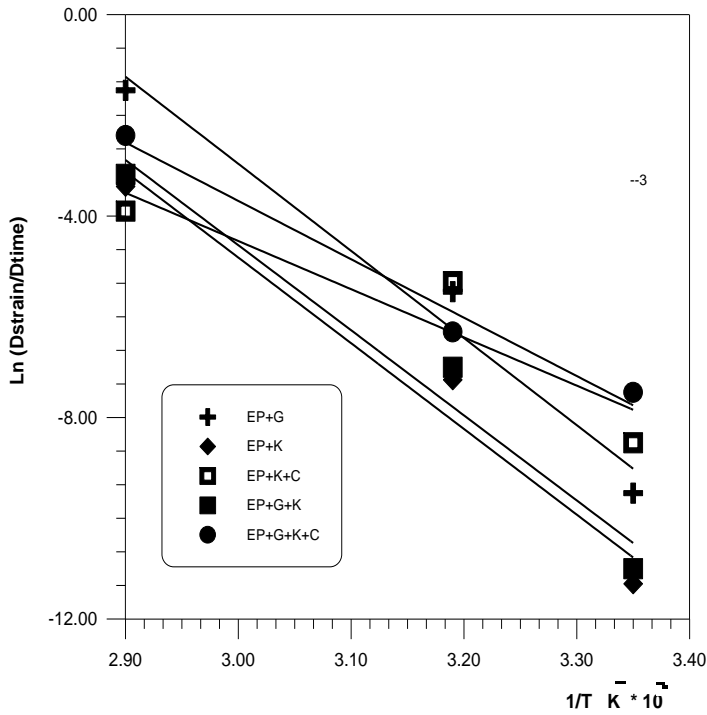

Fig (26) D strain / D time versus Temperature plot for UP composites



44 g (27) Ln (D strain / D time) versus 1/T plot for EP composites

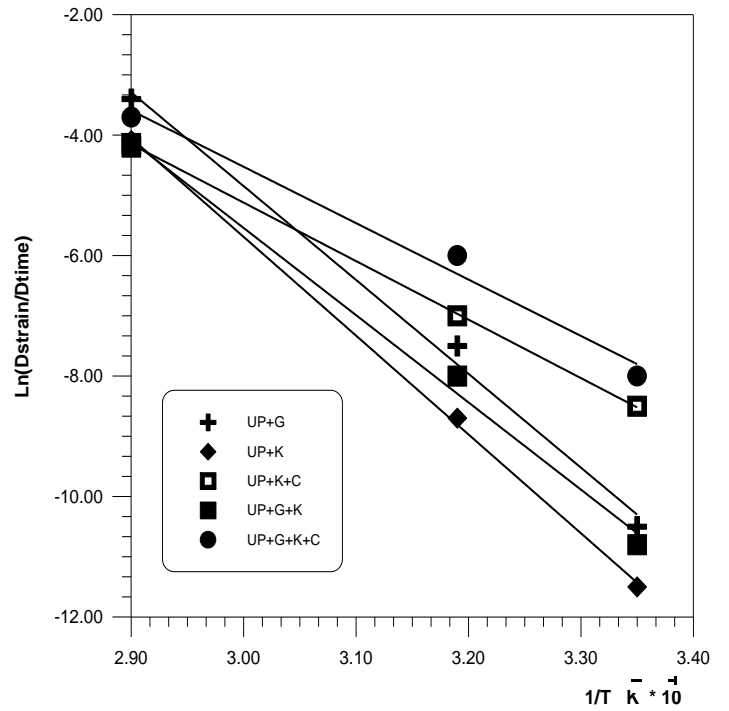

Fig (28) Ln (D strain / D time) versus 1/T plot for UP composites

دراسة تزحف متراكبات أنبوية الشكل مدعمة الألياف

د.عدنان عبد الجبار عبد الرزاق

مدرس

قسم الهندسة الكيماوية- الجامعة التكنولوجية

د.حسن شاكر مجدي

مدرس

د. نجاته جمعه صالح

استاذ مساعد

د. حسين علي حميد

مدرس

وزارة العلوم و التكنولوجيا

الخلاصة

في البحث الحالي تم تصنيع مواد متراكبة أنبوية باستخدام نوعين من الراتجات وهي الايبوكسي و البولي استر غير المشبع وتم تسليح هذه الراتجات بالألياف بصورة منفردة حيث استخدمت ألياف الزجاج، الكاربون و الكفلر 49 (بشكل خيوط أو حصيره محاكه) كما تم استعمال هجين من هذه الألياف لاجل تسليح الراتجات أيضا. تشمل عملية تصنيع المتراكبات الانبوية بطريقه اللف الخيطي، تصميم و تصنيع قالب معدني للحصول على هذه الأشكال و بعدها تتم عملية ترطيب الألياف أولا بأمرأها خلال محلول الراتنج ثم لفها على قالب التشكيل باستخدام مخرطة حورت لهذا الغرض للحصول على الأشكال الانبوية المطلوبة و بزوايه لف 55 درجة للألياف . أظهرت اختبارات الزحف بان الانفعال في درجات الحراره العاليه اسرع بكثير عند مقارنته بتلك التي يظهرها بدرجة حراره الغرفه ، وهذا يحصل بصوره أساسيه بسبب ان جزيئات ماده البولميرييه تكون أكثر حريه في الحركه في درجات الحراره العاليه واتي تودي الى سرعه حصول التشوهات في النماذج . ووجد كذلك ان معامل الزحف يعتمد على نوع الالياف ، نوع الراتنج وكذلك نوع التأصر بين الليف و الراتنج ، أعلى قيمه لطاقه الزحف المحسوبه من التجارب العمليه ظهرت عند استخدام النماذج الهجينه .

الكلمات الدالة

التزحف، الشكل الانبوي، المواد المتراكبة