

Palmprint Recognition Using Contourlet Feature Extraction and Backpropagation Neural Network Classifier

Dr. laheeb M. Alzoubiady*

Ibrahim A. Saleh**

Abstract

Palm print biometrics technology is highest used for human identity verification in most of security application. In this research the automated biometric system based palmprint biometric technique is used. The procedure of implementation is divided into two Stages (Enrollment stage and Verification stage). Each stage is divide into three parts ,the first part is pre-processing techniques based on image requirement and cropping to achieve the better image for palmprint. The second part is feature extraction based on countourlet to obtain a good coaffiention and KL transform to have eign values that reduce the input .The third part is a classifier using backpropagation neural network to authentication. The automated biometric system is feasible, easiest to use, and effective in personal authentication using palmprint features with high detection rate (97%)

تميز الاشخاص باستخدام طبعة اليد بالاعتماد على التحويل الكنتولي في استخلاص الخواص
واستخدام الشبكات العصبية ذات الانتشار خلفا في عملية التصنيف

الخلاصة

تعتبر التقنية البايومترية (طبعة اليد) واحدة من اهم الطرائق المستخدمه في المقاييس الحيوية التي تستخدم في عملية التحقق من وثوقية هوية الشخص التي تستعمل في معظم تطبيقات الحماية والامن. في هذا البحث استخدمت طبعة اليد في عملية التحقق الالي للاشخاص ، إذ ان هذا التطبيق (الطريقة) يقسم الى مرحلتين اساسيتين (مرحلة تحقّق و مرحلة تسجيل) . كل مرحلة من هاتان المرحلتين تمر بثلاث عمليات برمجية الاولى عملية معالجة الصورة وقطع الجزء المطلوب والثانية عملية استخلاص خواص الصورة باستخدام التحويل الكنتولي الذي يساعد على الحصول على افضل معاملات للصورة ومن ثم استخدام تحويل (KL) الذي يساعد على الحصول على القيم المميزة لتلك الصورة والعملية الاخيرة هي عملية

- Assist. Prof. \ College of Computers Sciences and Math.\ University of Mosul
- Lecturer\ College of Computers Sciences and Math.\ University of Mosul

تصنيف باستخدام الشبكات العصبية ذات الانتشار خلفا للقيام بعملية التحقيق. .تمتاز هذه الطريقة في عملية التحقق بكونها عملية وسهلة الاستخدام ،كما تمتاز هذه الطريقة في عملية التحقق بكونها ذات فاعلية عالية في عملية لتحقُّق الشخصي التي تقدر عملية بنسبة 97 % .

1. INTRODUCTION

Biometric technologies for human identity verification is growing rapidly and showing its advancement towards usability of biometric security artifacts [1]. Biometric characteristics, including fingerprint, facial features, iris, voice, signature, and palmprint, etc. are now widely used in security applications. Each biometric characteristic has its own advantages and limitations. Among various biometric techniques, palmprint recognition is getting popular in personal authentication because it provides robust features from a large palm area and the palmprint image can be captured with a cost-effective device [2].

Accurate and robust personal authentication become a crucial issue in the modern electronic world, and biometric techniques are promising solutions to this problem. Palmprint is an important member of biometric characteristics because it contains a rich amount of stable texture features, which lead to very high recognition accuracy. Meanwhile, the merits such as low-cost, user friendliness and high matching speed make it practicable to use in a large scale [3].

Palmprint based biometric technology is composed of three main steps :(namely or data requirement, feature extraction and recognition). Image features are extracted and collected as input vector while the remaining step is to recognize or classify that vector into the suitable class to identify people [4].

In this research, the automated biometrics system designed to identify individuals depended on a palmprint is proposed. The palmprint in the research obtained from digital camera with different size images. A normalization step is done before feature extraction depending on a contourlet feature extraction method to obtain the global attributes of a palm and using KL transform to obtain the eigenvalues and backpropagation neural network to identify the individual.

The rest of this paper is organized as follows : Section 2 obtained the related works Section 3 gives our proposed method in extracting principle lines of palmprint. In Sections 4 and 5, the experimental results and discussion are presented, respectively. Finally, the conclusion and the future work are provided in Section 6.

2. RELATED WORKS

In recent survey, Kumar et al. [4] introduces bimodal personal authentication system by integrating hand-shape and palmprint features, simultaneously acquired from the single hand image. The research combination features from hand-shape and palmprint image segmentation to be useful in achieving higher performance, probabilistic classifier (naive Bayes).The experimental results usefulness of shape properties (e.g., perimeter, extent, convex area) which can be effectively used to enhance the performance in hand-shape recognition. [4]

Li Shang et al. [5] propose a novel and successful method for recognizing palmprint based on Radial Basis Probabilistic Neural Network (RBPNN). The RBPNN is trained by the Orthogonal Least Square (OLS) algorithm and its structure is optimized by the recursive, the algorithm (ROLSA), which is pre-processed by a fast fixed-point algorithm for Independent Component Analysis (fastICA) .The experimental results show that the

RBPNN achieves higher recognition rate and better classification efficiency than other usual classifiers.

Sakdanupab et al. [6] have proposed and implemented a palmprint classification method based on principle lines. The phase of principle line extraction is based on profiles of gray values within a window of size 3x3 in four directions (0, 45, 90, and 135 degrees). The principle lines consisting of heart line, head line and life line are extracted and used for recognizing people afterwards.

Tunkpien et al. [7] have proposed and implemented methods to extract the principle lines of palmprint. The methods are based on applying a cascade of consecutive filters. Smoothing filter is used as the preprocessing step to discard noise. First derivative filter and closing filter are applied for finding the location of principle lines. The thresholding filter is subsequently applied. In addition, connected component labeling is finally used as the post processing step to remove the noise generated in between the process. The results are acceptable with 86.18 % of accuracy.,

Kekre, et al. [8] presents a performance comparison of palm print recognition techniques based on fractional coefficients of transformed palmprint image using six different transforms like Sine, Cosine, Walsh, Slant, Hartley and Haar. In transform domain, the energy of image gets accumulated towards high frequency region . The experimental results in Sine, Walsh, Haar, Cosine transform have shown performance improvement in palm print identification using fractional coefficients of transformed images. In all Cosine transform at fractional coefficients of 0.78% gives best performance as indicated by higher GAR value. Thus the task of speeding up the process of palmprint

Ajay, at el.[9] investigates a new approach for the personal recognition using nonlinear rank level combination of multiple palmprint representations which are used in multibiometric . The comparative experimental results from the realhand biometrics data to evaluate/ascertain the rank level combination using (i) Borda count, (ii) Logistic regression/Weighted Borda count, (iii) highest rank method and(iv) Bucklin Method are showed. The experimental results presented that significant performance improvement in the recognition accuracy can be achieved as compared to those from individual palmprint representations.

The drawbacks for the above researches are in below

1. Kumar et al., of this method use a hand shape ,that does not give adopted property because the shape for any person's hand varies with age ,as also used cosine transformation which is based on small coefficients that do not give the accuracy for biometric.
2. Li Shang et al, based on fastICA algorithm to obtains the coefficients from image ,the drawback of this algorithm depends on random variable and observations .It doesn't give accurate result .
3. Sakdanupab et al. , The drawback of this method is that noise is not completely eliminated by the proposed noise reduction process. In addition, their algorithms take too much processing time.
4. Tunkpien et al, The accuracy is not the highest when compared with the other existing methods .
5. Kekre et al, the drawback of this method is that it used six transfers ,It is inappropriate in real time application .
6. Kumar at el.the disadvantage of this method is that it used alarge number of coefficients inspite of giving high accuracy but the implementation is oftion slow.

In our research we used the countourlet transform to give a good coefficients and to show the edge ,and use of the KL transform to reduce the input data

3. PROPOSED BIOMETRIC SYSTEM

In a proposed biometric system, figure 1, there are two stages, enrollment and verification stages. During **Enrollment stage** a sample of the biometric trait is captured, processed and stored for later comparison. A system can also be used in **Verification stage**, where the biometric system authenticates a person's claimed identity from the imperviously enrolled pattern.

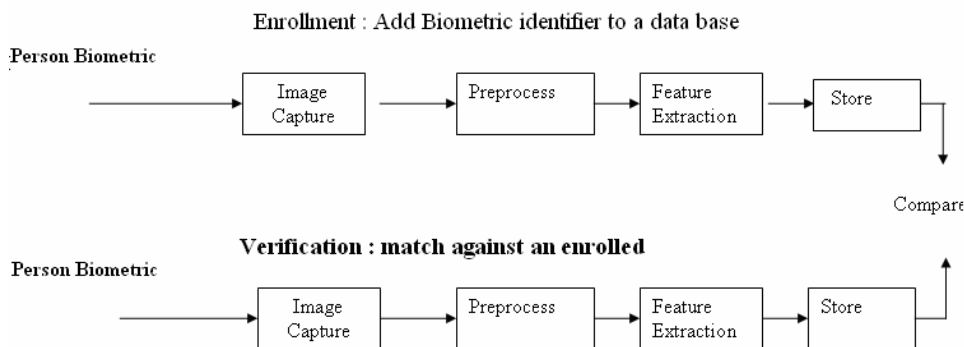

Figure 1 Biometric system stages

3.1 ENROLLMENT STAGE

In Enrollment stage, digital camera is used to acquire the biometric data from an individual. In this stage, many hand images of an individual are collected as the training samples. These samples should be processed by the pre-processing module; feature extraction module to generate the matching templates, these modules are done in the following steps:

STEP 1: IMAGE REQUERMENT AND CONVERTED INTO GRAY SCALE :

The hand images size 574*539 RGB are acquired from digital camera(figure 2a).Its normalization is in the size (256* 256) and converted to gray levels(figure 2b),To converted in to grayscale using equation (1) that is forming Weighted (X) of the color compound(red, green, and blue) and summation of these weighted rates.

$$Gray = 0.2989X * R + 0.7870X * G + 0.1140X * B.....(1)$$

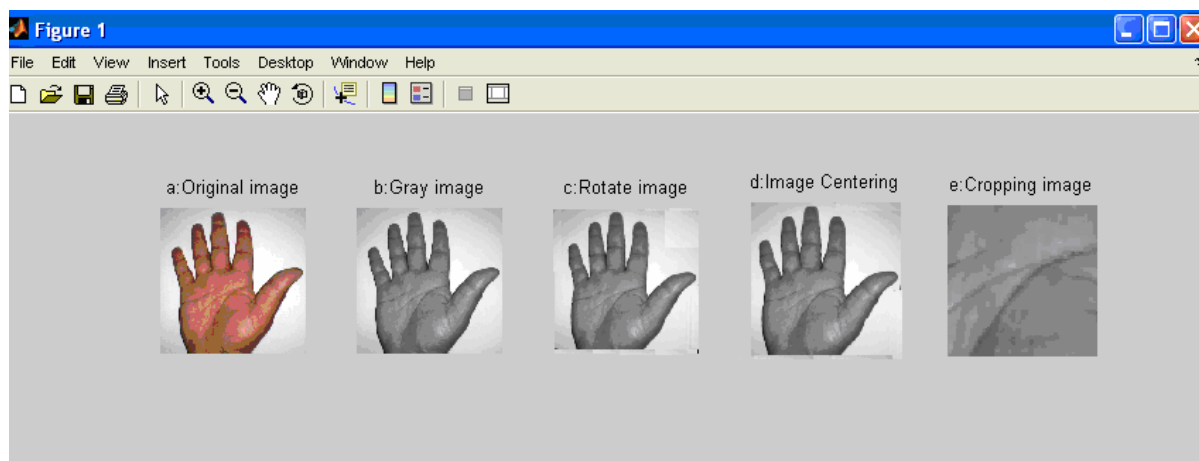

Figure 2 Preprocessing for hand images

STEP 2: IMAGE ROTATE: after the image-converted step, the images are traced to obtain the contours of hand shape by rotating the hand image through angle ALPHA

counter clockwise direction around an axis described by the 2-element direction vector [THETA, PHI], spherical coordinates shown in figure2c.

STEP 3: IMAGE CENTROID: The purpose of this step is to put the image output from image rotate step in the center of the frame by eliminating all blank pixels in left and right of the image ,by means of the centroid of the area occupied by the image from a frame, figure 2d.

STEP 4: IMAGE CROPE: Cropping means removing unnecessary borders of hand image , the image to crop and the rectangle to crop out .The next thing done is to create a Bitmap of the image. This is done by cloning the useful part from original image taking a rectangle of the original. , figure 2e.

Discrete Contourlet Transform(CT) and KL transform methods are used as feature extraction to cropp the boundary of a palmprint image, because CT is designed to capture the high frequency content like smooth contours and directional edges, see figure 3 [10].

Contourlet Transform (CT) addresses feature extraction by providing two additional properties, directionality and anisotropy. Contourlet Transform (CT) provides more efficient representation of an object because most natural images contain diverse orientation. The contourlet is mainly based on the Laplacian pyramid and the directional filter banks, as shown in Figure 3, In the Laplacian pyramid, the spectrum of the input image will be divided into the low pass, sub band and the high pass sub band. Then, the low pass sub band will be down sampled by two both in the horizontal and vertical direction and passed to the next stage. The high pass sub band will be further separated into several directions by the directional filter banks we will introduce the main flow of the contourlet, and the performance of the contourlet will be compared with the conventional separable 2D wavelet by the image compression and image denoising applications.[10, 11].

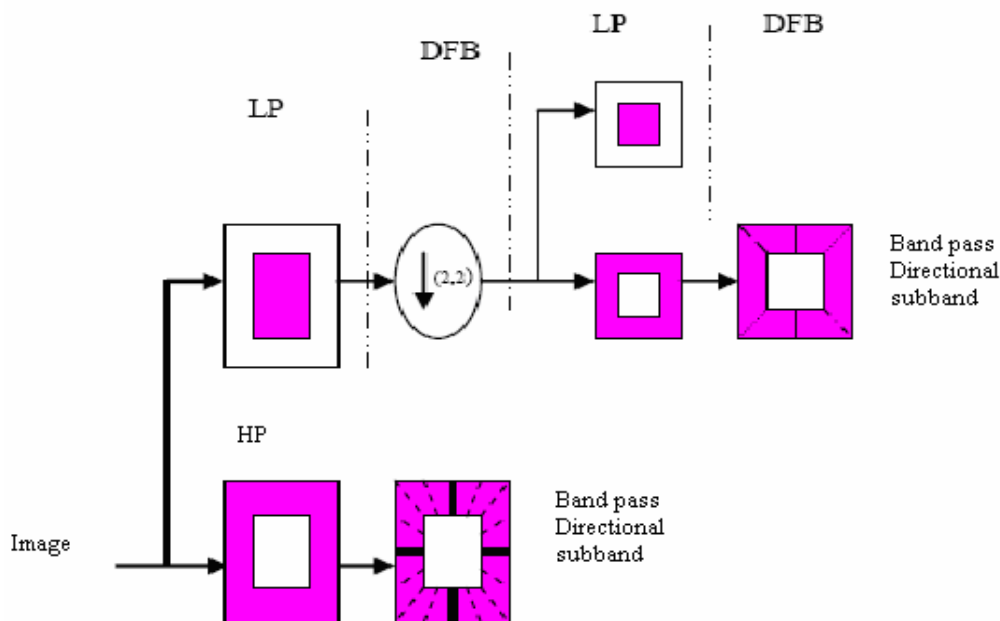

Figure 3 Double filter bank decomposition contourlet transform bands by the Laplacian pyramid is computed, and then a direction filter bank [10]

In the double filter bank structure, Laplacian Pyramid (LP) is used to capture the point discontinuities and then followed by a Directional Filter Bank (DFB), which is used to link these point discontinuities into linear structures.

One way to obtain a multiscale decomposition is to use the **Laplacian Pyramid frames(LP)**.The LP decomposition at each level generates a down sampled low pass

version of the original and the difference between the original and the prediction, resulting in a band pass image. The LP decomposition is shown in Figure 3. Here, the band pass image obtained in LP decomposition is then processed by the DFB stage. LP with orthogonal filters provides a tight frame with frame bounds equal to 1.[10]

The Iterated **Directional Filter Banks (DFB)** are used to derive of the high frequency subbands with diverse directionality. It is designed to capture the high frequency content like smooth contours and directional edges. The DFB is implemented by using a k -level binary tree decomposition that leads to 2^k directional sub- bands with wedge shaped frequency partitioning as shown in figure 4. But, the DFB used in this work is a simplified DFB which is constructed from two building blocks. The first is a two-channel quincunx filter bank with fan filters. It divides a 2-D spectrum into two directions, horizontal and vertical. The second is a shearing operator, which amounts to the reordering of image pixels. Due to these two operations, directional information is preserved. This is the desirable characteristic in CBIR system to improve retrieval efficiency. Combination of a LP and DFB gives a double filter bank structure known as Contourlet filter bank. Band pass images from the LP are fed to DFB so that directional information can be captured. The scheme can be iterated on the coarse image. This combination of LP and DFB stages result in a double iterated filter bank structure known as Contourlet filter bank. The Contourlet filter bank decomposes the given image into directional sub-bands at multiple scal. Decomposition of image using Contourlet Transform (2-level and filter for pyramid and directional filter) [11].

Following a similar procedure outlined in , for an l -level DFB we have 2^l directional subbands with G_k^l , $0 \leq k < 2^l$ equivalent synthesis filters and the overall down sampling matrices of $(S_k^{(l)})$, $0 \leq k < 2^l$ defined as[11]:

$$S_k^{(l)} = \begin{cases} \begin{bmatrix} 2^{l-1} & 0 \\ 0 & 2 \end{bmatrix}, & \text{if } 0 \leq k < 2^{l-1} \\ \begin{bmatrix} 2 & 0 \\ 0 & 2^{l-1} \end{bmatrix}, & \text{if } 2^{l-1} \leq k < 2^l \end{cases} .$$

The DFB is implemented by using a k -level binary tree decomposition that leads to 2^k directional sub- bands with wedge shaped frequency partitioning ,when applying CT to the palm print for two levels the coefficients of image appeared briefly in figure 4[11]

To apply the contourlet for palm print image for two level: in first stage **Laplacian Pyramid** that decomposes the image in two sub bands(cells) one for lowpass filter and other high pass filter to detect the edge ,and the next stage for **directional filter banks (DFB)** we apply the bank of filter to multi direction for the image of HPF and apply this process to the image LL to obtain coefficient for palm print that appears in the high left angle in figure(4)

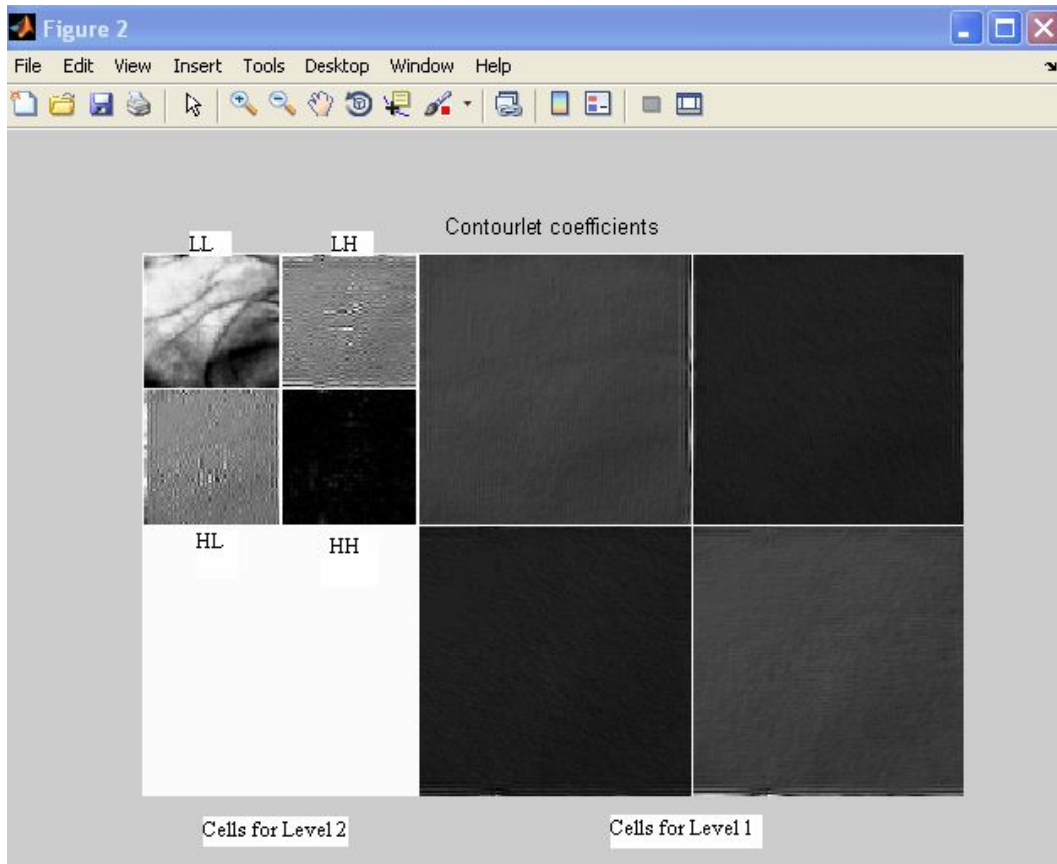

Figure 4 Two level contourlet decompose palmprint image

The image as a result from CT is used as an input to KL transform to obtain the eigenvalues. The KL transformation is also known as the principal component transformation, the eigenvector transformation which deals with information extraction. In Mathematics a two-dimension image can be represented as one dimension vector by concatenating each row (or column) into a long thin vector. The covariance matrix of the input data is calculated starting from the algorithmic mean of all vectors I_1, I_2, \dots, I_i . [12]

$$\psi = \frac{1}{M} \sum_{i=0}^M I_i \dots \dots \dots (2)$$

The difference image vector I_i and mean is called with

$$\Phi_i = I_i - \psi \dots \dots \dots (3)$$

The theoretical Covariance matrix C of all i is

$$C = \frac{1}{M} \sum_{i=0}^M \Phi_i \Phi_i^T \dots \dots \dots (4)$$

All Eigenvectors v_i and Eigen values λ_i of this covariance matrix are derived from the relationship.

$$\lambda_i = \frac{1}{M} \sum_{i=0}^M (v_i^T \Phi_i^T)^2 \dots \dots \dots (5)$$

The collection of M eigenvectors V_i can be seen as the reduced dimension representation of the original input image. This set of eigenvectors will have a corresponding Eigenvalues associated with it, which indicates the distribution of this eigenvector in representing whole dataset. The small set of eigenvectors with top Eigenvalues is enough to build up the whole image characteristic.

$$\varepsilon = \sum_{i=0}^P v_i \dots \dots \dots (6)$$

Applying KL transform to the image is obtained from Contourlet transform of the palm images. This transformation used KL method to reduce the original dimension of the image, thus the dimensions are greatly reduced and the most representative features of the whole dataset still remain within only Eigen features(16 eigen values).

3.2 VERIFICATION STAGE

In the verification stage, a query sample is also processed by the preprocessing and feature extraction modules, and is then matched with the templates to decide whether it is a genuine sample or not. Backpropagation (BP) neural network used as verification modules

Backpropagation is used in this research first, because of the advantages of Bp Neural networks, with their remarkable ability to derive meaning from complicated or imprecise data, can be used to extract patterns and detect trends that are too complex to be noticed by either humans or other computer techniques[13]

One of the techniques used for the verification is correlation factors in addition to the Mean Square Error(MSE) equations(7) (8)required these verification

$$corr. fac = r_{xy} = \frac{\sum_{i=1}^n (x_i - x_j)(y_i - y_j)}{(n-1)S_x S_y} \dots \dots \dots (7)$$

where x_j and y_j are the sample means of x and y , and s_x and s_y are the sample standard deviations of x and y

$$MSE(t) = \frac{1}{n} \sum_{i=1}^k f_i(x_i - t)^2 \dots \dots \dots (8)$$

Algorithm of BP is described briefly by Srinivasa [13], For training BP Neural Network, weight matrix of Training Dataset obtained from the Contourlet and KL – transform (16 eigen values) are used as the input nodes to the Neural Network. When a new image from the test set is considered for recognition, the image is mapped to Contourlet, eigen value subspace and weights are calculated for the particular image. The number of output nodes is equal to the number of total images (**10-one for each person**), to be classified. A threshold value represents the classification matching to the target and 0 represents the classification far away from the target. Weight vector is used to feed the respective neural network and the object recognition results will be obtained. . The unit functions for input layer and hidden layer were logarithmic sigmoid transfer function. Back propagation training is implemented with Gradient descent with momentum

4. EXPERIMENTAL RESULTS

In this section, some experimental results are demonstrated to verify the validity of our approach, in environment stage, digital camera is used to capture the hand images. 8 hand images of each individual are obtained to ten persons (80 hand images) for training group (enrollment stage) and (40 hand images) for testing group (Verification stage) (4 images for each individual).

In the enrollment stage, the 80 images are used to train the verification model. The verification system is programmed by using Matlab ver.10. The experimental results verified by BP neural network algorithms are reported. After execute proposed biometric system, the best architecture of BP neural network is 16 input nodes for each image, nine hidden nodes , 10 output nodes with learning rate equal to 0.005 ,and activation function

is sigmoid activation function, see figure 5, and 400 epochs, the detection rate in enrollment stage equal to 98% .

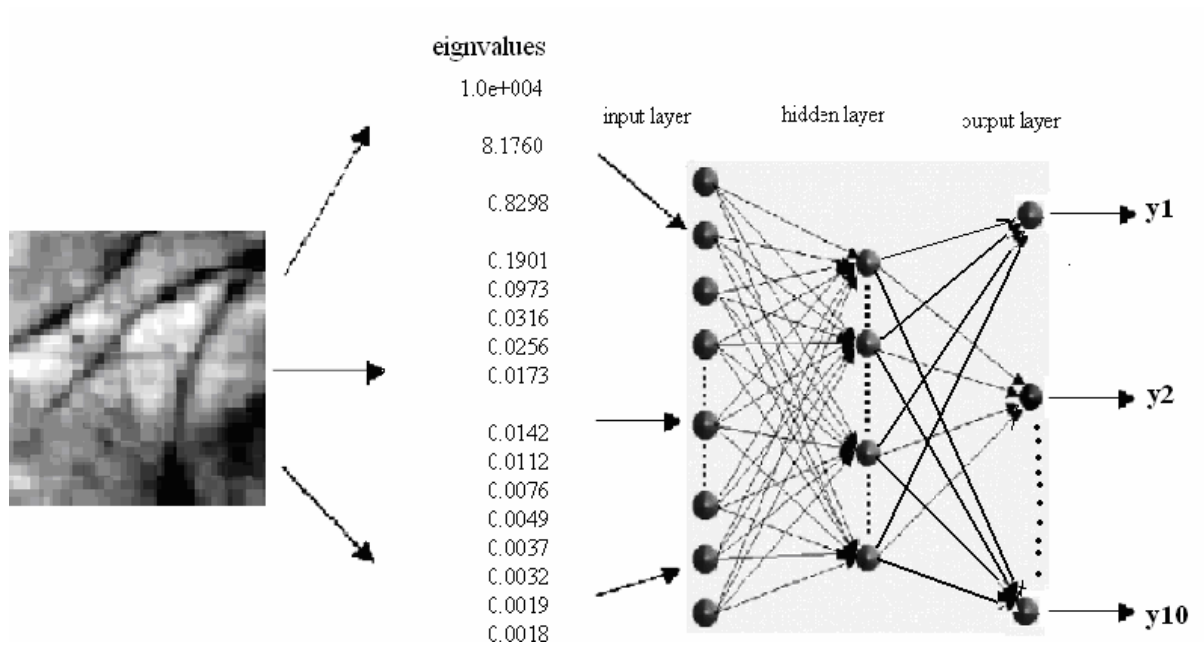

Figure 5 Backpropagation neural network (sigmoid activation function)

In the testing phase, the average accuracy rates are above 96 % and morphological features. Besides, both FAR(False Acceptance Rate) and FRR(False Rejection Rate) values are below 4%.

We explain these two terms:[

FAR large number of fraud attempts have to be undertaken to get statistical reliable results. The fraud trial can be successful or unsuccessful. The probability for success (FAR(n)) against a certain enrolled person n is measured[14]

$$FAR = \frac{1}{N} \sum_{n=1}^N FAR(n) \dots \dots \dots (7)$$

FRR a large number of verification attempts has to be undertaken to get statistical reliable results. The verification can be successful or unsuccessful. In determining the FRR, only fingerprints from successfully enrolled users are considered. The probability for lack of success (FRR(n)) for a certain person is measured[14]

$$FRR = \frac{1}{N} \sum_n FRR(n) \dots \dots \dots (8)$$

Our proposed testing results in comparisons to others are depicted in table 1. We can find that our biometric automated is system greatly competitive with other and Fig. 6 indicates that our system can achieve a high detection rate.

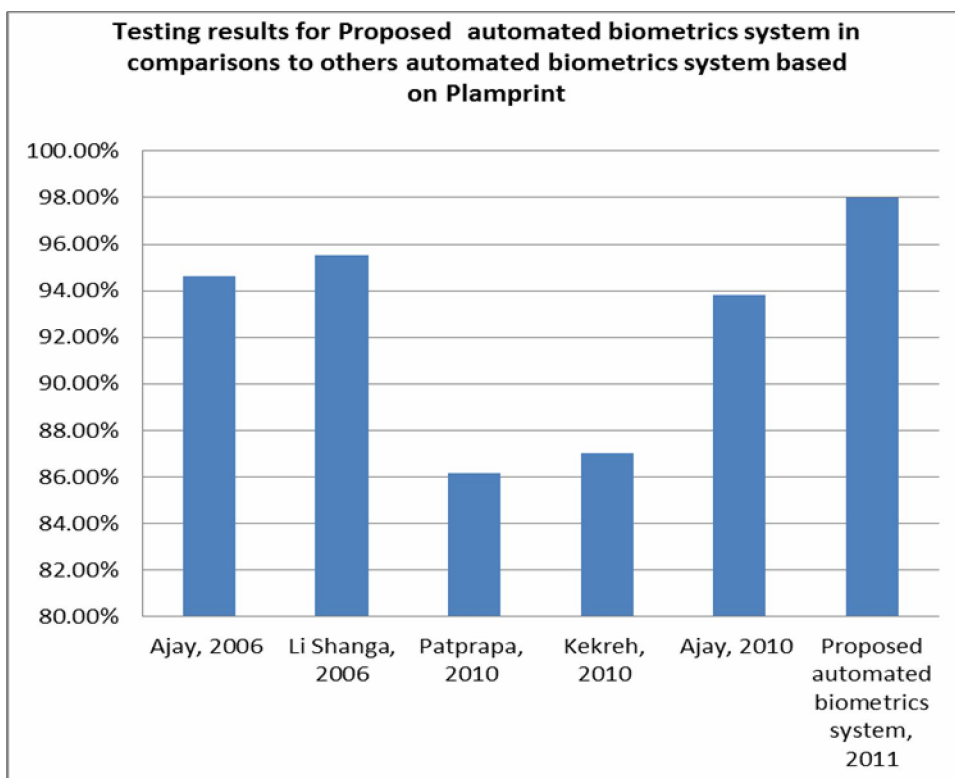

Figure 6 Testing results for Proposed automated biometrics system in comparisons with other automated biometrics system based on Plamprint

Table 1. Testing results for Proposed automated biometrics system in comparisons with other automated biometrics system based on Plamprint

Research	Recognition method	Database	(PSC) for test dataset
Kumar et al, 2006 [4]	Hand shape and discrete cosine transform coefficients and decision tree classifier	The dataset consisted of 1000 images, ten images per subject, which were obtained from digital camera .	94.6%
Li Shanga, 2006 [5]	palmprint based on radial basis probabilistic neural network(RBPNN)	The database includes 600 palmprint images from 100 individuals, with 6 images from each individual.	95.53%
Sakdanupab,2010 [6]	The phase of principle line extraction is based on profiles of gray values within a window of size 3x3 in four directions (0, 45, 90, and 135 degrees)	It contains 7,752 grayscale images corresponding to 386 different persons with 20-21 images for each in bitmap file format. Only 193 images are selected to test at random	The results achieve 86.18%.
Tunkpien ,2010 [7]	Extract the principle lines of palmprint by using consecutive filtering	The database consists of image 7,752 grayscale images corresponding to 386 different	86.18 %

	operations related to gradient and morphological operators.	persons with 20-21 images for each in bitmap file format. Only 193 images are selected to test at random in this research	
Kekreh, 2010 [8]	It used methods for transformation (Sine, Cosine, Walsh, Slant, Hartley and Haar.	The database of 2350 palmprint images is used as a test dataset	78%.
Ajay, 2010 [9]	personal recognition using non linear rank level combination of multiple palmprint representations.	- 234 and 100 subjects palmprint image database - We have also investigated approach on NIST BSSR1 dataset (both on 517 subject and 6000 subject sets)	Eign palm feature 93.8%
Proposed automated biometrics system, 2011	Feature extracted using contourlet and KL transforms ,to recognition with BPANN	80 images for training 40 images for testing	96%

6. Conclusions

In this research, a novel approach is presented to authenticate individuals by using their palmprint features. The hand images are captured from a digital camera, then preprocessed images to appear suitable and comfortable for all users, and extracted features using contourlet transform and then used KL transform to reduce to the input values for the back propagation network. Besides, we propose verification mechanisms based on backpropagation neural network to verify the palmprint images. We can obtain above 96% accuracy rate. Experimental results reveal that our proposed approach is feasible and effective in personal authentication using palmprint features.

In our experiments, the samples are verified by backpropagation neural network algorithms. In this experiment, the average accuracy rates are above 96 % . Besides, both FAR and FRR values are below 4%. Experimental results verify the validity of our proposed approaches in personal authentication. Therefore automated biometrics system designed to identify individuals from such pieces of multiple evidences, *i.e.*, multibiometrics, can effectively achieve higher performance.

For future work, the researchers suggest the design of an automated biometrics system based on 3D Palmprint Matching, and using dynamic leaning rate values for Bp neural network to compare to have a best recognition rate.

References

- [1] Dakshina R., Phalguni G., JamunaKanta Sing, "Offline Signature Identification by Fusion of Multiple Classifiers using Statistical Learning Theory" International Journal of Security and Its Applications, Vol. 4, No. 3, July, 2010, 35-45.
- [2] David Zhang , Zhenhua Guo, Guangming Lu, Lei Zhang, Yahui Liu, Wangmeng Zuo, "Online Joint Palmprint and Palmvein Verification, Expert Systems with Applications" ESWA 5101 No. of Pages 11, Model 5G 3 September 2010.
- [3] Wei Li1, 2, Lei Zhang, David Zhang, Guangming Lu, Jingqi Yan, "Efficient Joint 2D and 3D Palmprint Matching with Alignment Refinement" , IEEE, 978-1-4244-6983-3/10, 2010.

- [4] Ajay Kumar, and David Zhan,” Personal Recognition using Hand Shape and Texture”, IEEE TRANSACTIONS ON IMAGE PROCESSING, VOL. 15, NO. 8, AUGUST 2006.
- [5] Li Shanga,b, De-ShuangHuangb,_, Ji-Xiang Dua,b, Chun-HouZhenga,b, “Palmpoint Recognition using FastICA Algorithm and Radial Basis Probabilistic Neural Network, Neurocomputing” , (2006), 1782–1786 www.elsevier.com/locate/neucom.
- [6] PatprapaTunkpien, Sasipa Pandu wadeethorn, Suphakant Phimoltares, “Compact Extraction of Principle Lines in PalmpointUsing Consecutive Filtering Operations”, Proceedings of the Second International Conference on Knowledge and Smart Technologies 2010 (July, 24-25, 2010).
- [7] Tunkpien , Patprapa et al, “Compact Extraction of Principle Lines in Palmpoint Using Consecutive Filtering Operations”Advanced Virtual and Intelligent Computing (AVIC) research centerDepartment of Mathematics, Faculty of Science, Chulalongkorn University, (July, 24-25, 2010)
- [8] KekreH.B., Sudeep D. Thepade, AshishVarun, Nikhil Kamat, Arvind Viswanathan , “Performance Comparison of Image Transforms for Palm Print Recognition with Fractional Coefficients of Transformed Palm Print Images”, International Journal of Engineering Science and Technology, Vol. 2 (12), 2010, 7372-7379.
- [9] Ajay Kumar1, SumitShekhar, ” Palmpoint Recognition using Rank Level Fusion”, Proceedings of 2010 IEEE 17th International Conference on Image Processing September 26-29, 2010, Hong Kong.
- [10] Bin Yang, Shutao Li, Fengmei Sun,” “Image Fusion using Non sub Sampled Contourlet Transform”, Proceedings of the4th International Conference on Image and Graphics, ICIG 2007, pp. 719–724.
- [11] EslamRamin i and Radha Hayder “Wavelet-Based Contourlet Transform and its Application to Image Coding” ECE Department, Michigan State University, East Lansing, MI 48824, USA,2004.
- [12] Mario Mastriani, and Juliana Gambini, “Fast Cosine Transform to Increase Speed-up and Efficiency of Karhunen-Loève Transform for Lossy Image Compression” International Journal of Information and Mathematical Sciences 6:2, 2010.
- [13] Srinivasa Kumar Devireddy, Settipalli Apparao, “Hand Written Character Recognition using Backpropagation Network”, Journal of Theoretical and Applied Information
- [14] Karthik Nandakumar “Multibiometric Systems: Fusion Strategies and Template Security” thesis Doctor of Philosophy, Department of Computer Science and Engineering, Michigan State University, 2008