

Transmission System On-Line Fault Location Using Artificial Neural Network

Dr. Adil Hameed Ahmed* & Hatim Ghadhban Abood *

Received on:3/6/2009
Accepted on:7/10/2009

Abstract

In this work, protection systems for overhead transmission lines are investigated and an efficient technique for on-line fault location based on Artificial Neural Network(ANN) is suggested. First, Studying and investigating the power transmission lines short circuit modeling and analysis, and then developing a MATLAB programs to calculate fault currents and voltages for different fault types depending on the location of the fault in the transmission line and finding the location of this fault. The proposed technique for the fault location is the two -end data technique. The pre-fault data plus the fault data construct a training set for the neural network programs which contain two types, one for fault detection and classification, and the other for the fault location. Then, these programs are applied on the Iraqi super grid (400 kV).

Keywords: Artificial Neural Network, Fault location, two-end data, fault detection.

التحديد اللحظي لموقع العطل في منظومة النقل بأستخدام الشبكة العصبية الصناعية

الخلاصة

تم في هذا العمل , بحث نظم الحماية لخطوط النقل الكهربائية لاقتراح تقنية كفوة لتحديد موقع العطل مستندة للشبكات العصبية الصناعية . في البداية تم دراسة وبحث نمذجة وتحليل دائرة القصر لخطوط النقل, ومن ثم تطوير برنامج MATLAB لحساب تيارات و فولتيات العطل لمختلف انواع الاعطال اعتمادا على موقع العطل في خط النقل , بالإضافة الى ايجاد الموقع لهذا العطل وقبلها يتم تهيئة بيانات الشبكة لما قبل العطل (تيارات و فولتيات حالة التشغيل الاعتيادية) . التقنية التي استخدمت لحساب موقع العطل هي تقنية بيانات النهايتين . أن بيانات ما قبل العطل أضافة الى بيانات العطل تشكل مجاميع تدريب لبرامج الشبكات العصبية والتي تحوي نوعين , الأول لكشف العطل و تصنيفه و الآخر لايجاد موقع العطل . تم تطبيق هذه البرامج فيما بعد على الشبكة العراقية الفائقة (400 كيلو فولت).

Introduction

Power systems consist of three main stages: generation stage, power transmission stage, and distribution stage. So, transmission lines are

conjunction parts without them no electrical power would be supplied to the consumers. An important objective of all the power systems is to

*Electrical and Electronic Engineering Department, University of Technology / Baghdad

maintain a very high level of continuity of service, and when abnormal conditions occur, to minimize the outage times. Protection systems are responding to detect the faults or abnormal operation conditions and to initiate corrective action [1]. Each part on the power system has its own protection equipments which differ from the others in one feature or more according to these parts functions. In this work the pilot protection system is the preferred system to achieve the suggested method, because the step distance protection does not offer instantaneous clearing of faults over 100% of the line segment. This system is also called *Unit - protection* because of in this type the transmission line is considered as a one unit protection region. In this system the information regarding the location of the fault is transmitted from each terminal to the other terminal(s). A communication channel is used for this transmission line protection. Four types of communication channels are used for pilot relaying[1]:

Power line carrier, Microwave channels, Fiber-optic cables, and Pilot wire channels. Like differential relays, pilot relays provide primary zone protection without backup.

Overhead transmission lines are exposed to the environment and the possibility of experiencing faults on the lines is generally higher than that on the other components. Line faults are the most common faults, they may be triggered by lightning strokes, trees may fall across lines, fog and salt spray on dirty insulators may cause insulator strings to flash over, and ice and snow loadings may cause insulator strings to fail mechanically

When a fault occurs on a transmission line, it is very important to detect it, determine its type, and find its location in order to make necessary repairs and to restore power as soon as possible. The time needed to determine the fault point along the line will affect the quality of the power delivery. Therefore, an accurate fault location on the line is an important requirement for a permanent fault.

2 Short Circuit Modeling

2.1 Two-End Data Technique for fault location

Present communications technology allows for use of data from both ends of the transmission line. The calculation of fault location using data from two ends is fundamentally similar to the single-ended methods except now a means exists to determine and minimize or eliminate the effect of fault resistance, loading, charging current, and other similar factors that tend to throw off the accuracy of the estimate. The data from both ends must be gathered at one location to be analyzed. The collected data must also be at least roughly synchronized from each end before analysis is performed [2].

The system represented in figure (1) can be used to illustrate the approach used in locating faults based upon information gathered from two terminals

Two-terminal fault location techniques are usually based on the following approach. As shown in figure (2), the fault is at location (F) which has a distance of (m) [per-unit] from the Bus (S), and (1-m) [per unit] from Bus (R). The voltage at the fault is denoted as V_F , and the bus voltages and currents are as indicated in this figure. Use of voltage/current

relationships in all three phases a, b, and c yields the results are[2]:

$$(V_{FS})_{abc} = m (Z_L)_{abc} (I_{FS})_{abc} + V_F \dots(1)$$

$$(V_{FR})_{abc} = (1-m) (Z_L)_{abc} (I_{FR})_{abc} + V_F \dots(2)$$

Subtracting these two equations to eliminate the unknown V_F and write the equation in terms of single phase because the symmetry results:

$$V_{FS} - V_{FR} = m Z_L I_{FS} + (m-1) Z_L I_F \dots(3)$$

$$I_{FS} + I_{FR} = (V_{FS} - V_{FR} + Z_L I_{FR}) / m Z_L \dots(4)$$

This equation can be solved for the real (m), and the phase values can be substituted with the symmetrical components. This equation shows that elimination of the fault resistance effect required to addition the two ends voltages and subtraction the two sides fault currents. This exactly what will be used to perform the proposed method. The two- end data technique will require many equipments such as: microprocessor-based relay to measure three-phase voltages and currents at each end with time code, Modems and other communications equipment, technical personnel or computer equipment at central site for collecting data, performing analysis, and calculating fault location, and Remote communications and Supervisory Control and Data Acquisition (SCADA) system.

There is some suggested protection system to perform the fault location techniques. All of these systems are unit protection systems (pilot protection). To improve the real time operation, the application of synchronized sampling measurements of two –ends is used with the aid of neural networks. This method does not depend on any unknown setting, which makes it very robust, and the results are very accurate [3]. Global

Positioning System (GPS) of satellites can provide time-synchronization signal with higher precision for time reference and global clock to exceed the problem of cascade fault due to that its speed is in micro – seconds[4]. Figure (2) shows the configuration of this protection system. In this figure, CB represents circuit breakers, R/T refers to receiver /transmitter terminal, CT and VT represent current and voltage transformer, and SU refers to sampling unit which may contain IEDs, DFRs or Phasor Measurement Unit (PMU).

3.3 Fault Equations

Unsymmetrical faults are the most commonly fault types that may be occurred in the power system. Therefore, the short circuit modeling will implemented by using the symmetrical component [5,6].

For each fault type there are two sets of calculations: first one for the sending end bus (bus-k) and the other set is for receiving end bus (bus N). This will enable us to apply the two-terminal technique. Generally, the configuration for the fault between bus -K and bus- N (line K-N) is as shown in figure (3), where a bolted fault is considered. From this figure we conclude that:

$$Z_{F1} = m Z_L \text{ and } Z_{F2} = (1-m) Z_L$$

The calculations will be for the sending end (Bus-k) which was determined according to load flow results and the same steps will be repeated for bus-N, but with Z_{F2} instead of Z_{F1} , as well as change the subscript (K) to (N). Here we needed the Kth and Nth elements of Z-Bus which represent Thevenin's impedance for bus-K and bus-N respectively.

Then, the main equations for single-line-ground fault are:

$$I_k^0 = I_k^1 = I_k^2 = 1/3 I_k^a \quad \dots(5)$$

Substituting the values for V_k^0 , V_k^1 , and V_k^2 in Eq. (2.5), we get:

$$I_k^1 = \frac{E}{Z_{KK}^1 + Z_{KK}^2 + Z_{KK}^0 + 3 Z_{F1}} \quad (6)$$

The main equation for line-line fault are:

$$I_k^1 = \frac{E}{Z_{KK}^1 + Z_{KK}^2 + 2 Z_{F1}} = - I_k^2 \quad (7)$$

And the main equations for Double-Line –Ground fault are:

$$I_k^1 = \frac{E \left(Z_{kk}^0 + Z_{kk}^2 + \frac{3}{2} Z_{F1} \right)}{\Delta} \quad (8)$$

$$I_k^2 = \frac{-E \left(Z_{kk}^0 + \frac{3}{2} Z_{F1} \right)}{\Delta} \quad (9)$$

$$I_k^0 = \frac{E Z_{kk}^2}{\Delta} \quad (10)$$

Where:

$$\Delta = \left(Z_{kk}^0 + \frac{3}{2} Z_{F1} \right) Z_{kk}^2 + \left(Z_{kk}^0 + Z_{kk}^2 + \frac{3}{2} Z_{F1} \right) Z_{kk}^1$$

Finally, the equations for Symmetrical fault are:

$$V_k^1 = E - Z_{kk}^1 I_k^1 \quad (11)$$

$$I_k^1 = \frac{E}{Z_{kk}^1 + Z_{F1}} \quad (12)$$

$$I_k^2 = I_k^0 = 0 \quad (13)$$

The other phases currents and voltages are determined by using the symmetrical components.

Then, the same calculations are repeated for bus-N with Z_{F2} , and the ground fault current for single-line-ground fault will be:

$$I_{Fg} = I_K^a + I_N^a \quad \dots(14)$$

While the ground current for double-line-ground fault will be:

$$I_{Fg} = (I_K^a + I_N^a) + (I_K^b + I_N^b) \quad \dots(15)$$

While there is no ground fault current will flow in the ground link for the symmetrical fault because the phases currents will be equal in magnitude but, out-of-phase by 120° which leads to eliminate the ground current because $(1+a+a^2)=0$. The following equations give the ground fault current for symmetrical fault from bus-K [2, 6].

$$I_k^a + I_k^b + I_k^c = I_k^1 + a I_k^1 + a^2 I_k^1 = 0 \quad (20)$$

4 Software Implementation Procedure

The proposed programs was carried out primarily, as *off-line* implementation. The function of software part is to prepare the required program to be run *on-line* later. Software implementation contains two stages:

1. mathematical programs

stage: It contains the programs that prepare the required data to the second stage such as: Normal operation data, which results from by Load flow program which gives us the normal operation currents and voltages. Also, Z-Bus matrices must be built in this stage. As well as short circuit programs which contain four programs for the different fault type's.

2. Neural Network (NNs)

programs stage: which contain two types: Neural Network for fault Detection and Type Classification

(NNDT), in it the NNs are constructed and trained to detect and classify the faults type according to input data sets from the first stage. The next programs are the Neural Networks for fault Location (NNL). It consists of one program for each fault type and gets its input data from the short circuit programs in the first stage. These programs are carried out using MATLAB-7 package.

5 Programs Run and Output Files

The main fault types that are taken into consideration in this work are:

1. Single –Line – Ground fault program (S-L-G), which will produce output set-A-.
2. Line -Line fault program (L-L), which will produce output set-B-.
3. Double –Line –ground fault program (D-L-G), which will produce output set-C-.
4. Symmetrical fault program (SYMMT). which will produce output set-D-.

Short circuit programs supply the neural networks with four data sets are needed for learning and training the NNTs. The output matrix dimension will be (8×k), where: k= (11* No. of bus-bars), where the number (11) represents the eleven location on the line from (m=0) to (m=1) with a step of (0.1 p.u). The distance (0) per-unit represents fault on the sending end bus-bar which is marked as bus-bar (S), while (1) refers that the fault occurs at the receiving end bus which is marked as bus-bar

(R). Fault programs depend on the previous short circuit equations. The output data file for fault programs is shown below:

Line No. / Val / Vbl / Vcl / Ifa / Ifb / Ifc / Ifg

In addition to these fault sets there is a normal operation data set which called set-N.

6 Artificial Neural Network

Artificial intelligence (AI) is the science of making machines to do things that would require intelligence if done by humans. The Artificial Neural Networks (ANNs) have established themselves as a promising tool in power system control and analysis. They have been valued especially in problems where there are too many combinatorial possibilities, leading to large solution times, in tasks of statistical character or in identification and modeling of parts of the system [7].

The Back Propagation (BP) Algorithm is used to train the NNs programs. The Back Propagation (BP) method is the most effective and most widely used learning method for the training of multilayered neural networks (MLNN) that uses differentiable activation functions and supervised training [8]. One of the most common activation functions used in BP is the sigmoid function and it's defined as[8]:

$$f(x) = \frac{1}{1 + \exp(-\lambda x)} \quad (21)$$

$$f'(x) = f(x)[1 - f(x)] \quad (22)$$

Where: f (x) is the activation function and the constant (λ)

determine the steepness of the rise. Like the delta rule, the BP is an optimization procedure based on gradient descent that adjusts weights to reduce the system error. The name back propagation arises from the method in which corrections are made to the weights. In the learning phase, input patterns are represented to the network in some sequence. Each training pattern is propagated forward layer by layer until an output is computed. The computed output is then compared to a desired or target output (supervised training) and an error value is determined. The errors are used as input to feedback connections from which adjustments are made to the synaptic weights in a backward direction [7]. Therefore the BP is an iterative gradient algorithm designed to minimize the mean square error between the output of the multilayer neural network and the desired output.

6 Neural Network Programs

It was referred that neural network programs represent the second stage of software implementation and they consist of: Neural Network for fault Detection and Type classification (NNDT), Neural Network for fault Location (NNL).

NNDT program has cumulated the output files of the first stage programs: set-A, set-B, set-C, set-D, and set-N, to construct the input matrix (p), then building the target matrix (T) which determine the case of operation (healthy or faulty) and the type of faults. Target matrix has the same number of rows of input matrix (p) which has a number of rows equal to $(11 \times \text{No. of lines})$. Target matrix (T) contain (0) and (1) numbers only like a binary digit, first three digit for lines

and the four one for the ground. Table (1) shows sample of target matrix of NNDT for each operation state, while figure (4) shows the configuration of NNDT network, where: (h_n) refers to number of hidden neurons.

NNDT program works as activation stage for NNL Programs which will not to be work if the output of NNDT is [0 0 0 0]. But, if the output of NNDT is equal to one of the second, third, fourth, or fifth row of the previous table, the NNL will be activated to calculate fault location.

NNL programs consist of four NN programs, one program for each fault type. The target matrix for each NNL program will be the same which consists of four binary digits [$2^3 \ 2^2 \ 2^1 \ 2^0$]. Table (2) shows how the target matrix for fault location will be seen. A one set of input data (fault currents and fault voltages) will be given to NNL network. Figure(5) shows the configuration of NNL network, where: (L_n) refers to line index.

These NNs had been carried out by using Multi-Layer Feed Forward Network (MLFFN) and they are trained by the error back propagation algorithm.

7 Iraqi Super Grid Test

The Iraqi national grid was taken to be a real network to test for fault location. Generally, Power transmission system in the national network contain two levels: high-voltage level (132 kV) and extra-high voltage level (400 kV) or a super grid as it is called in Iraq. High-voltage level (132 kV) is a large and complicated network contains (231) bus-bars and (421) lines. So, the short circuit calculations on this level will

be complicated and huge and consequently, the learning time for NNs would be increased extremely, because of the limited capabilities of the personal computers. Therefore, the program was carried out using the super grid (400 kV) which contain (23) substations (or bus-bars) and (38) transmission lines [9].

The required data were supplied by Iraqi National control (Dispatch) Center (NDC). Figure (6) shows the national super grid of (400 kV), where: the prefix (B) refers to bus-bar index and the prefix (L) refers to line index and the black color names refers to abbreviation of substations name. Noting that this information is updated at 1/ 4/ 2009.

The base quantities for the super grid are as follows: base MVA is (100 MVA), base voltage is (400 kV), and the base current is (144.34 Ampere) and the slack –bus is BAJP [9]. To prevent the accumulated error on the training sets to NNs programs which are the more interest section in the proposed technique, we preferred to get the load flow and Z-Bus data from the National Dispatch Centre. As well as, these requested data helps us to separate the (400 kV) level from the entire grid by using bus-bars voltages which resulting from the load flow process as a Thevenin's – voltages and the bus impedance diagonal elements (Z_{KK}) as a Thevenin's –impedances.

In the Iraqi super grid, the significance of fault calculation on the line itself (not on the neighboring bus-bars) will appear, where for the long lines which exceed(150 km), the variances in voltages and currents will be clear and extreme . The longest line is line -5- (BAJP –BGW4) which has a tall of (233 km) [8].

Therefore, fault at point (F) on line-5- is supposed to be occurred with

different values for fault location position (from $m=0$ to $m=1$ p.u.). The four fault programs had carried out and the results are shown in figures (7 and 8). These figures show that the two-end measurements technique is better than the one end measurements to determine the fault types and fault location. As shown in figure (7), the difference in fault currents along the line is great, for example for S-L-G fault, fault current varying between (52.5 p.u.) and (115 p.u.) which is greater than the variation in values of the other fault types. But, this variance still smaller than that of one end calculation.

Figure (8) shows the fault voltages resulting from a fault calculation on line-5- on the Iraqi super grid. Again the wide difference in results with the fault location is appearing in the voltage results. The other observation is that the terminal quantities (at the two ending bus-bars) for both fault currents and fault voltages are not the same, where the shapes are not symmetrical neither on the terminal nor on the mid-point ($m=0.5$ p.u.), where the minimum value point is not on the midpoint exactly. This due to many reasons such as the different load flow values which leads to different pre-fault voltages for the two-ends buses of the line, and because of the terminal buses are from a different types, i.e. the sending end bus which is (BAJP), is considered as generation- bus ,while the receiving bus (BGW4) is a load – bus. Therefore, the contribution on fault quantities from the two ends is not the same.

These short circuit calculations are repeated for each line in the network to obtain four data sets of short circuit results as well as the data set of normal operation state. These results

construct a large matrix which has dimensions of (8×1710) . These sets are used as an input matrix to train NNDT and NNL, where figures (9.a and 9.b) show the learning performance curves for NNDT and NNL respectively.

The time and epochs that required to learn the NNDT are low with a highly accuracy of (10^4) , while The time and epochs that required to learn the NNL increased directly with the size of the network where, for Iraqi super grid, it needed to (1580) epochs and (331) seconds to achieve the learning process (with a little difference for each fault type).

After learning the entire NNs programs and save the final weights, the saved learning information is loaded to the final fault detection, classification and location program where, the comparison and the decisions are taken. Sample sets of measurements are given to test the program and their results are shown in figure (8). The time that is elapsed for each line process is between (0.015 and 0.03 sec.). So, the maximum time required for (38) lines are about (1.14 sec.). This time enable us to distinguish the successive faults. Especially, when the synchronization in time by the GPS system is applied.

8 Conclusions

From the results of application on the Iraqi power grid, we conclude that:

1. The method of fault analysis according to measurements from the two end of the line has verified its efficiency in determination the fault location on the line while, the most previous methods are calculate the fault on the bus-bar itself with ignoring line

impedance therefore, they has been making serious errors in the decisions.

2. Neural network programs have verified its ability for training on the different function which they are designed for them, by using the back propagation algorithm to reduce the error of learning. But these results leads to state that fault detection and classification type program is approximately unaffected with the network size, while the fault location programs will need to computers of high ability to satisfy the requirements of the network expansion.
3. The proposed method is efficient sufficiently to be a software package in service of Iraqi national dispatch centre because, the required time for each line process is between(0.015 and 0.03 sec) which represent a suitable time for on-line control.

References

- [1]. Horowitz S. H. , Phadke A. G., "Power system relaying ", Research Studies Press LTD. 1996.
- [2]. Power System Relaying Committee "IEEE Guide for Determining Fault Location on AC Transmission and Distribution Lines ", IEEE Power Engineering Society, IEEE Std C37.114™-2005.
- [3]. Kezunovic M., Knezev M., "Selection of Optimal Fault Location Algorithm", PSERC Publishing, 2008.

- [4]. Kezunovic M., Zheng C., "Monitoring Power System Dynamic Performance Using Synchronized Sampling ", International Conference on Advances in Power System Control, Operation and Management (APSCOM), Saint Petersburg, 2008.
- [5]. Saadat H., " Power System Analysis", McGraw-Hill, 1999.
- [6]. Grainger J. J. , Stevenson W. D., "Power System Analysis", McGraw-Hill, 1994.
- [7]. J. M. Zurada, "Introduction to Artificial Neural Systems ", JAICO House, 1996.
- [8]. S. Haykin, " Neural Network A Comprehensive Foundation", Prentice- Hall International, Inc., 1999.
- [9]. National Dispatch Centre (NDC), Baghdad, Iraq, April 2009.

Table (1) Target matrix elements of NNDT

| Operation case | | L | L | L | G |
|-----------------------|-----------|---|---|---|---|
| Normal operation | | 0 | 0 | 0 | 0 |
| F A U L T | L - G | 1 | 0 | 0 | 1 |
| | L - L | 0 | 1 | 1 | 0 |
| | L - L - G | 0 | 1 | 1 | 1 |
| | SYMMT. | 1 | 1 | 1 | 0 |

Table (2) Target matrix for NNL

| Fault Location | Output | | | |
|----------------|--------|---|---|---|
| 0% | 0 | 0 | 0 | 0 |
| 10% | 0 | 0 | 0 | 1 |
| 20% | 0 | 0 | 1 | 0 |
| 30% | 0 | 0 | 1 | 1 |
| 40% | 0 | 1 | 0 | 0 |
| 50% | 0 | 1 | 0 | 1 |
| 60% | 0 | 1 | 1 | 0 |
| 70% | 0 | 1 | 1 | 1 |
| 80% | 1 | 0 | 0 | 0 |
| 90% | 1 | 0 | 0 | 1 |
| 100% | 1 | 0 | 1 | 0 |

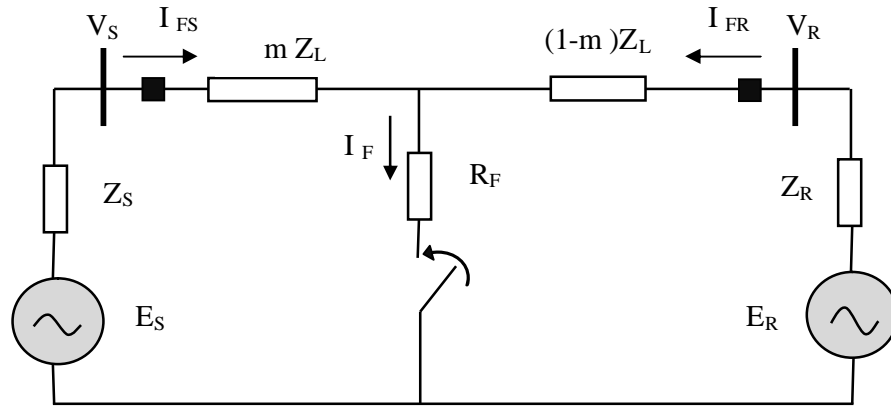

Figure (1) Equivalent circuit for a fault with two source[2].

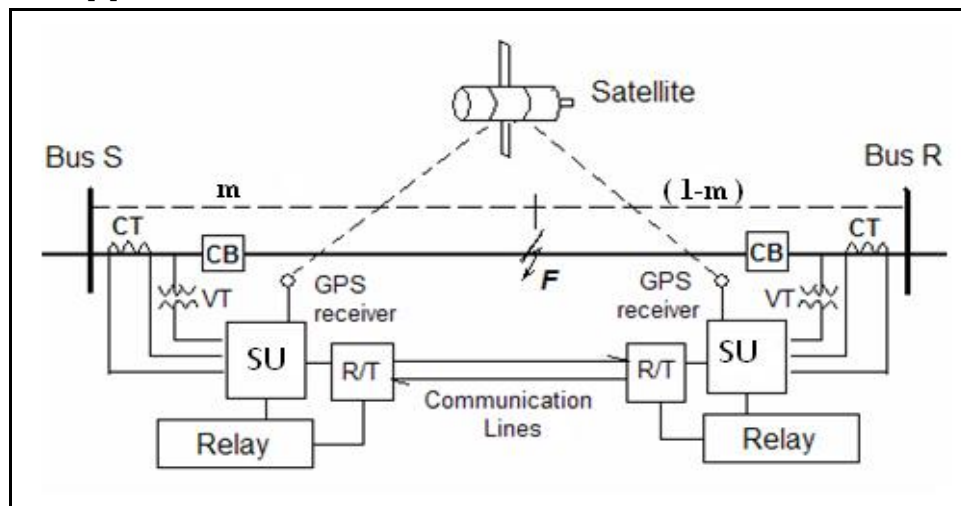

Figure (2) GPS- based fault location system [4].

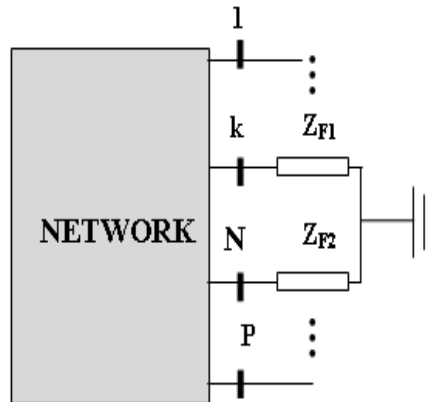

Figure (3) General configuration for faulted line (K-N).

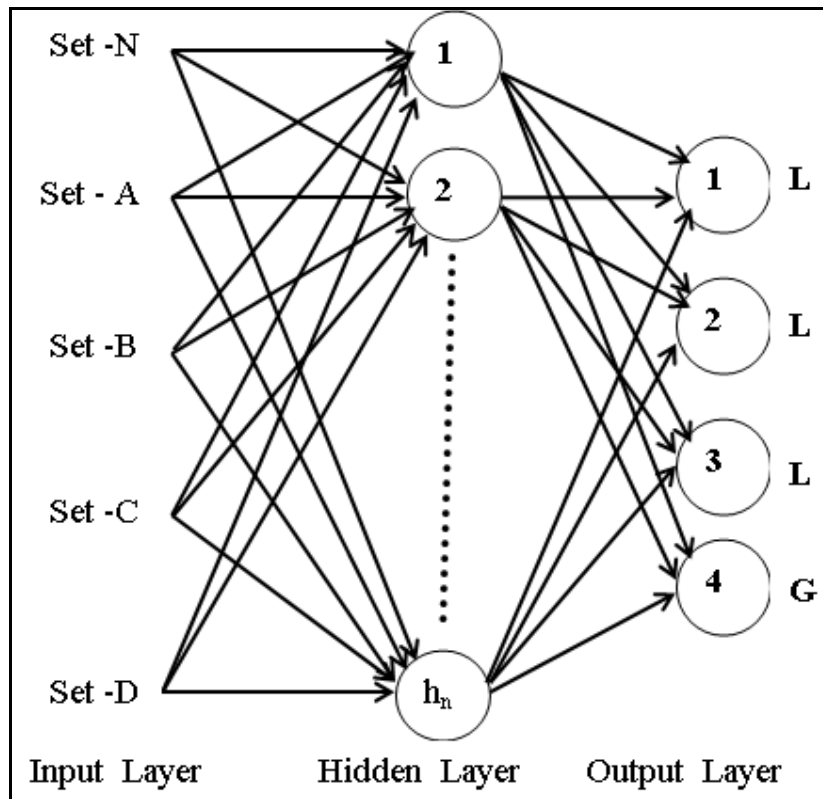

Figure (4) Configuration of NNDT network .

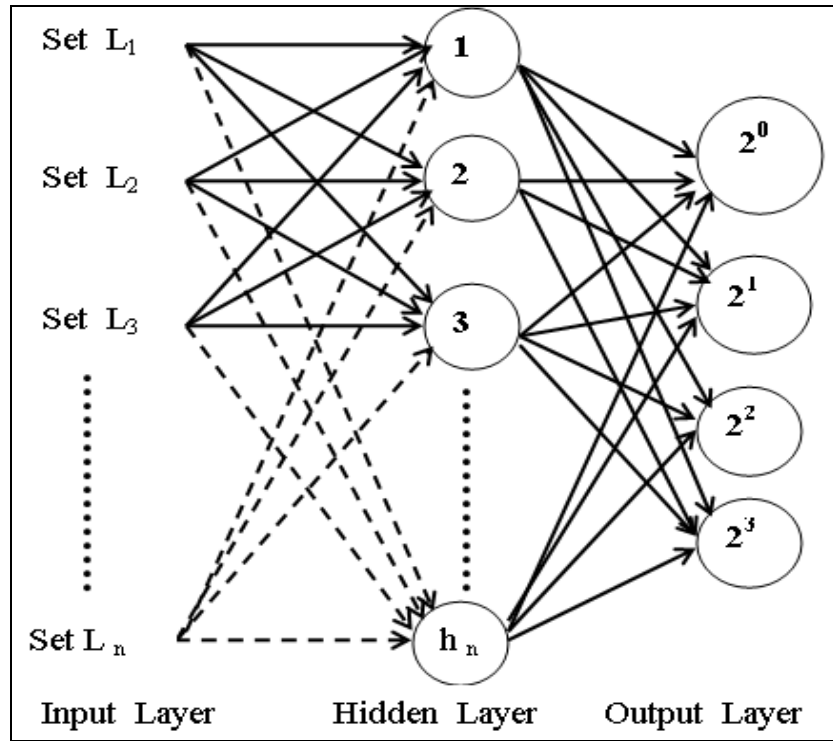

Figure (5) Configuration of NNL network.

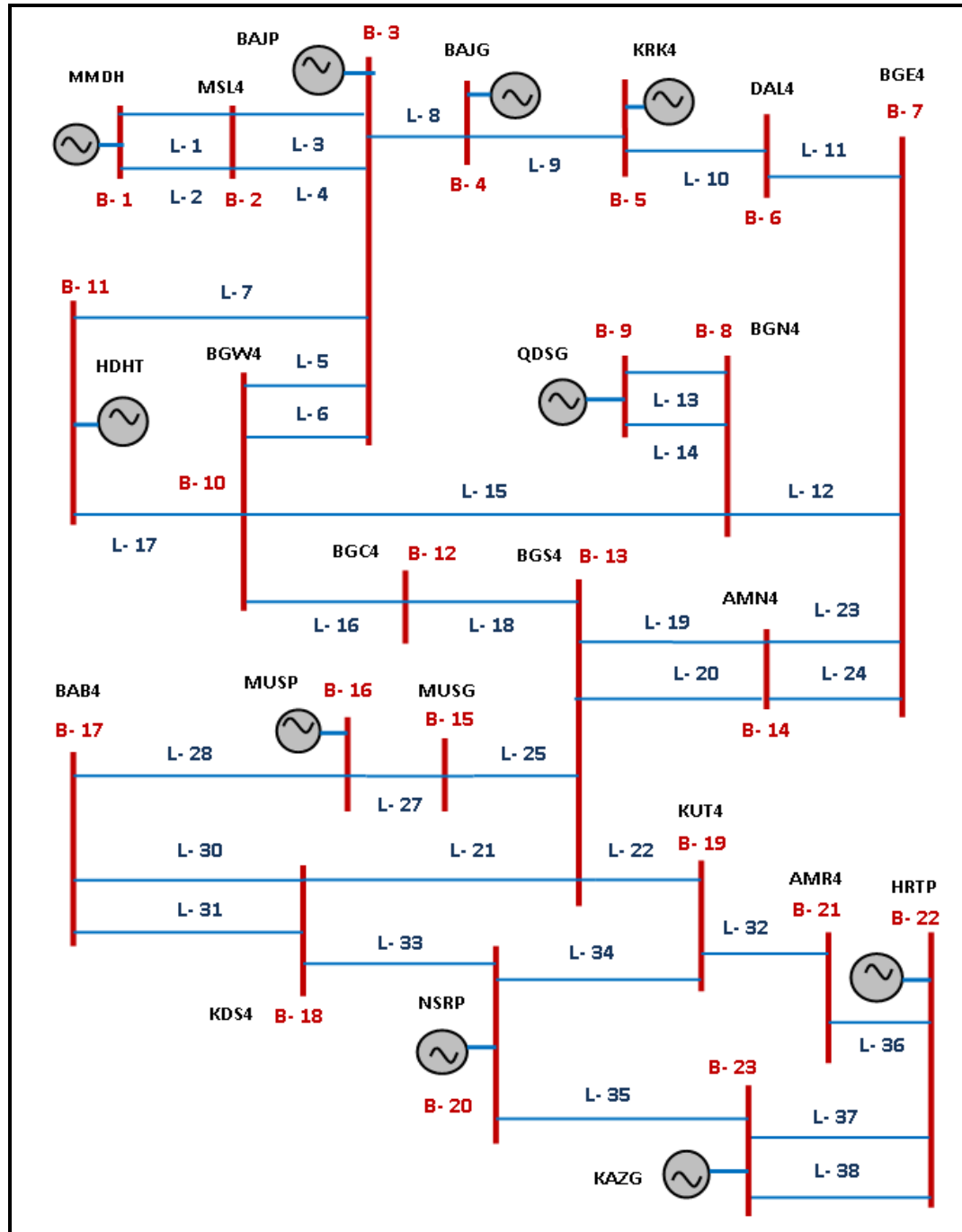

Figure (6) Iraqi super grid (400 kV) [9]

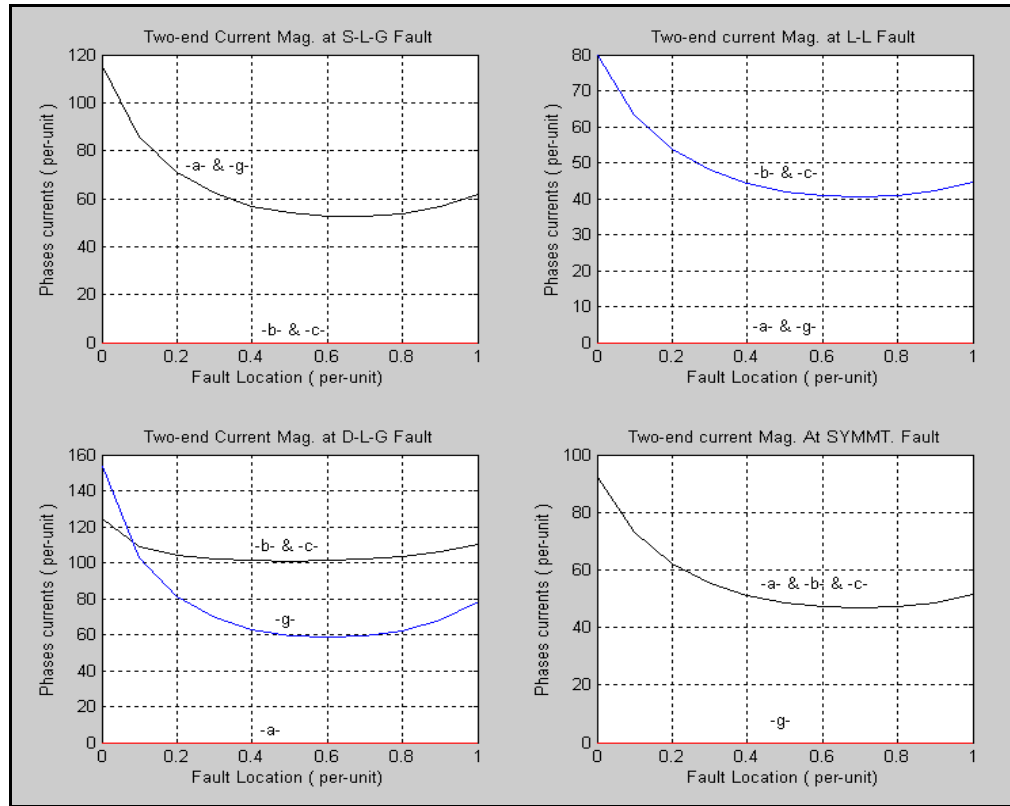

Figure (7) Currents for different faults on line-5- in Iraqi super grid.

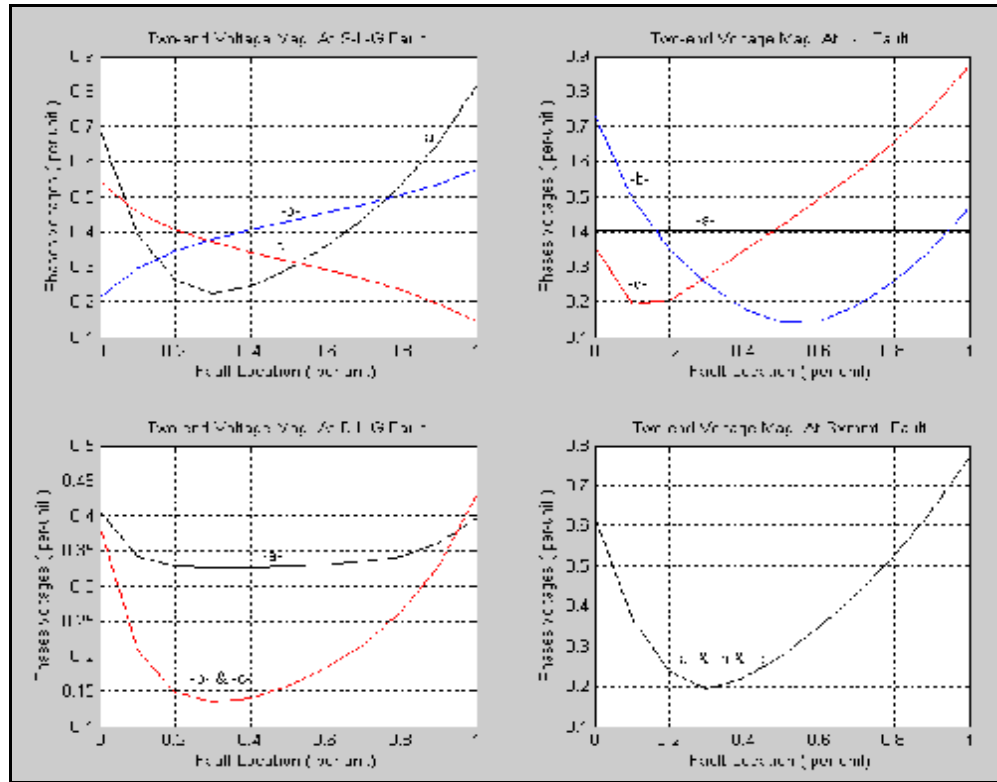

Figure (8) Voltages for different faults on line-5- in Iraqi super grid.

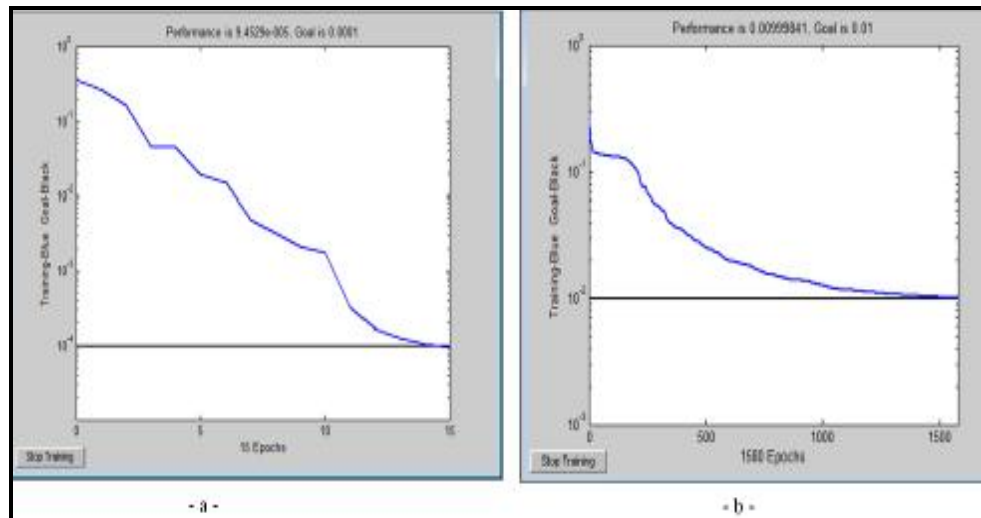

Figure (9) Learning performance curve for : - a- NNDT, -b- NNL.