

## **Ferrocement Structural Elements in Building/Housing Applications**

**Wail N. Al-Rifaie, Ph.D.  
Professor of Structural Engineering  
Building & Construction Engineering Dept.  
University of Technology, Baghdad-Iraq**

### **ABSTRACT**

The use of ferrocement in pre-fabrication of building/housing offers numerous advantages in terms of lightness of weight and ease of handling, low labour cost and a durable material requiring little maintenance.

A considerable amount of laboratory testing research and prototype constructions have been completed at the Building and Construction Eng. Dept. of University of Technology for the production of ferrocement members that would be used in the roof/floor/wall of building/housing.

The present paper describes the applications of ferrocement to housing/building constructions.

## 1. INTRODUCTION

The development of a suitable construction materials for low-cost building/housing and accelerated construction method are some of the different measures that will effect a greater economy in the cost of construction.

In the last two decades ferrocement has been used in the construction of different structures which include housing, roofing, water and grain storage, agricultural, irrigation, water supply and sanitary construction.

Ferrocement is considered a new type of construction composites in which the bonding material composed of cement and sand is reinforced with a fine wire mesh layers uniformly distributed within the matrix of the bonding material. It can also be regarded as a type of reinforced concrete but because its production, performance, resistance, and potentialities, we have to consider it as a completely separate material.<sup>(1,2,3,4)</sup>

The use of ferrocement in pre-fabricated buildings provides many advantages in terms of lightness of weight and ease of handling and low labour cost (skilled and non-skilled) involved in its production. Evidently, for these reasons ferrocement has gained advantage over other reinforced concrete and steel structures. It is durable and requires little maintenance.

## 2. CONSTRUCTION ELEMENTS MADE OF FERROCEMENT

A number of researchers has been carried out to find out the structural members which can be made of ferrocement and used in the construction of

roofs/floors and walls in building/housing. These structural members include:

- a. Structural member in the form of a beam having channel or box like cross-section or a beam having a cross-section of two channels jointed back-to-back by means of screws. These members are subjected to flexural moments (one-dimensional slab). These slabs are in various forms to match the space to be spanned resting at the shortest dimension on load bearing walls.
- b. Shell roof units.
- c. Structural member with angle, channel or box-like sections to construct load-bearing wall.
- d. Structural member with composite section of ferrocement and brick to construct wall/column.

## 3. Design and selection of Ferrocement Structural members

A great deal of research and experiments have been carried out on the fore-mentioned ferrocement structural members. Prototypes varying in the physical properties as well as in composition were cast and tested for flexural strength, cracking moments, ultimate moments, and deflections and methods have been proposed to estimate these quantities. Ferrocement columns/wall elements have been cast and tested under uniaxial loading and their load-carrying capacity studied. The experimental prototype constructions were compared with their counterparts made in traditional methods.

Standardized dimensions of beams, column/wall unit, composite columns and shell roof unit are listed in Figure 1, while Figure 2 gives the order of constructing these members of the suggested panel system for a roof and their relative

positions. Figure 3 shows the method to be used in constructing roofs, the way to distribute the ferrocement beams during roofing within the standardized dimensions between centers, and how to place these beams on the supporting walls. When juck arching is used to cover a small area, beam with composite sections as shown in Figure 1.c can be used as a substitute to I-shaped steel joists.

Ferrocement structural members are placed adjacent to one another to form load-bearing walls in buildings as shown in Figure 4 as a substitute to those made of brick and cement mortar or reinforced concrete walls.

#### **4. CONSTRUCTION OF BUILDING/HOUSING USING FERROCEMENT STRUCTURAL MEMBERS**

Using structural members in the construction of building/ housing involves pre-casting and pre-fabrication. The study is divided into four parts: construction method, architectural design, structural analysis of the members, their design and fabrication.

The construction method deals with such matters as transportation, erection and assembling on the site and cost estimation. Architectural design is concerned with the development of a structural system using ferrocement for industrialized purpose which ends up in being a panel system which gives the structure aesthetical properties, weight, length and at the time transportations are taken into consideration.

Structural analysis, on other hand, involves analysis and design of structural members. all aspects of analysis and design of panel system as well as the structure as a hole.

The fabrication part covers all production processes.

Figures (5,6,7,8,9) show some structures, which can be made by using ferrocement as structural members. Figure 5 shows a house and how a roof can be made by using the panel system. Figure 6 shows Kiosks<sup>(9)</sup> in which the main structural members of walls and roofs are made of ferrocement. These members have channel form. The panels were designed to be used as bearing walls as well as roofs and should be joined together by means of screws. Figure 7 shows the steps have been taken for installing the structural members of the Kiosk and how the walls joined to the concrete foundations. Plate (1) shows a photograph of a Kiosk with structural member made of ferrocement. Figure (8) illustrates a bus-stop shed in which structural members can be made from ferrocement. Figure (9) shows a public telephone Kiosk in which ferrocement structural members can be used.

#### **5. CONCLUSIONS**

The application of ferrocement to the construction of building/housing has been described in this paper.

The application of ferrocement to the construction of long span shell and dome structures has already been successfully completed.

**REFERENCES**

1. Al-Rifaie, W.N., and Trikha, D.N. (1987). Experimental Investigation of Secondary Strength of Ferrocement Reinforced with Hexagonal Mesh. *Journal of Ferrocement*, Vol.17, No.17, No.3, July.
  2. Al-Rifaie, W.N., and Trikha, D.N. (1988). Effect of Arrangement and Orientation of Hexagonal Mesh on the Behavior of Two-Way Ferrocement Slabs. *Ferrocement Applications and Progress, Proceedings of the Third International Symposium on Ferrocement, University of Roorkee, India, December.*
  3. Al-Rifaie, W.N., and Trikha, D.N. (1988). Assessment of Quality of Ferrocement Structures by Ultra-Sonic Test. *Ferrocement Applications and Progress, Proceedings of the Third International Symposium on Ferrocement, University of Roorkee, India, December.*
  4. Al-Rifaie, W.N. (1993). Ferrocement as a new Construction Materials. *Proceedings of the First International Conference on Implementing Local material in Industrial Application. Jordan, September.*
  5. Al-Rifaie, W.N., and Hassan, Arsalan, H. (1994). Structural Behaviour of Thin Ferrocement One-Way Bending Elements. *Journal of Ferrocement*, Vol.24, No.2, April.
  6. Al-Rifaie, W.N., and Nimmim, H.T. Structural Behaviour of Ferrocement Box Beams. To be Published.
  7. Al-Rifaie, W.N., and Aziz, A.A. (1995). Thin Ferrocement Bearing Walls. *Journal of Ferrocement*, July.
  8. Al-Rifaie, W.N., and Al-Hmedawi, A.N. Thin Ferrocement Shell Structures. Accepted for Publication, *Journal of Ferrocement.*
- Al-Rifaie, W.N., and Gabriel, S.H. (1994).  
Kiosk Guide. Baghdad Municipality, Iraq.

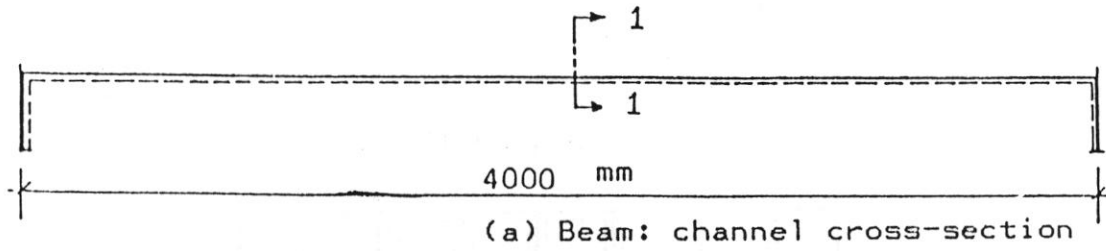

Section 1-1

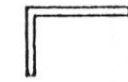
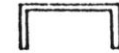

(e) Cross-sections of column/wall unit

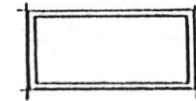
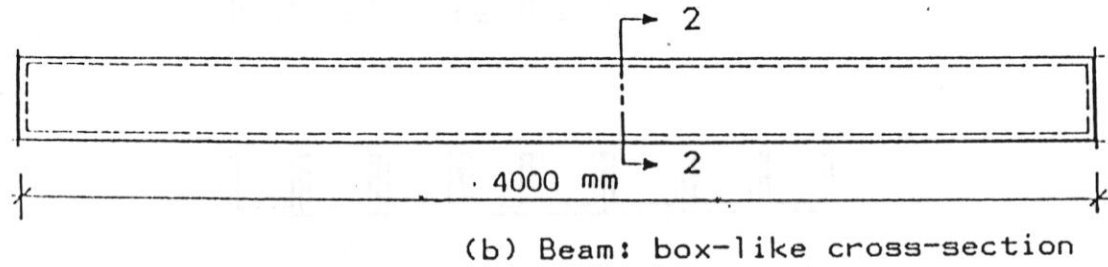

Section 2-2

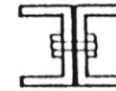
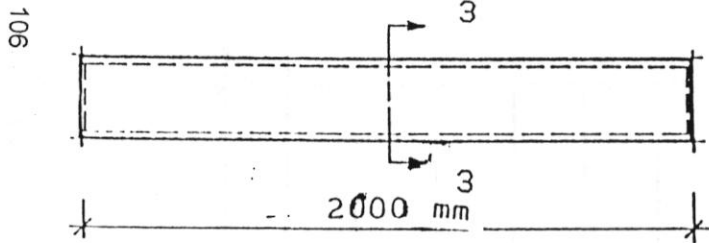

Section 3-3

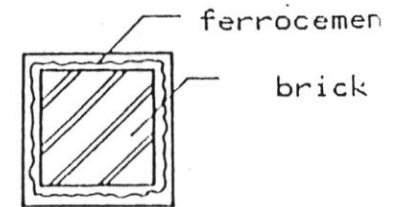

(f) Ferrocement-brick composite

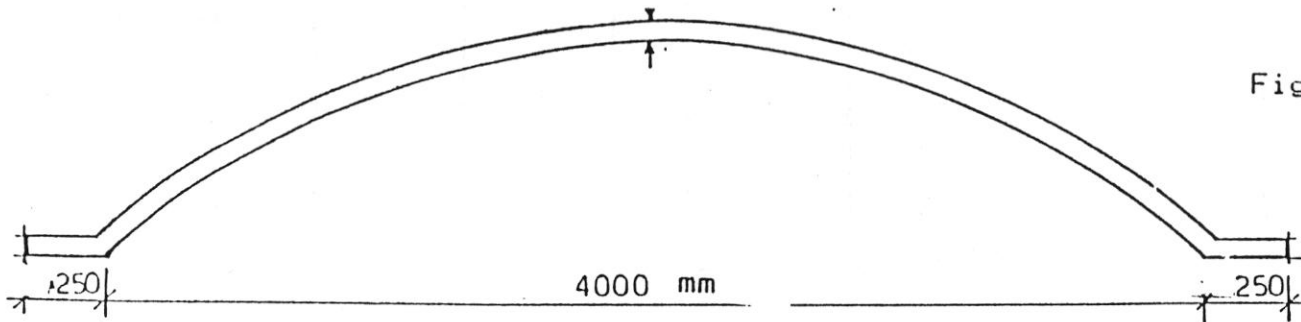
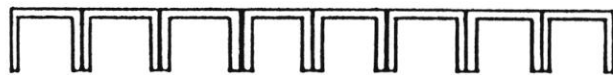
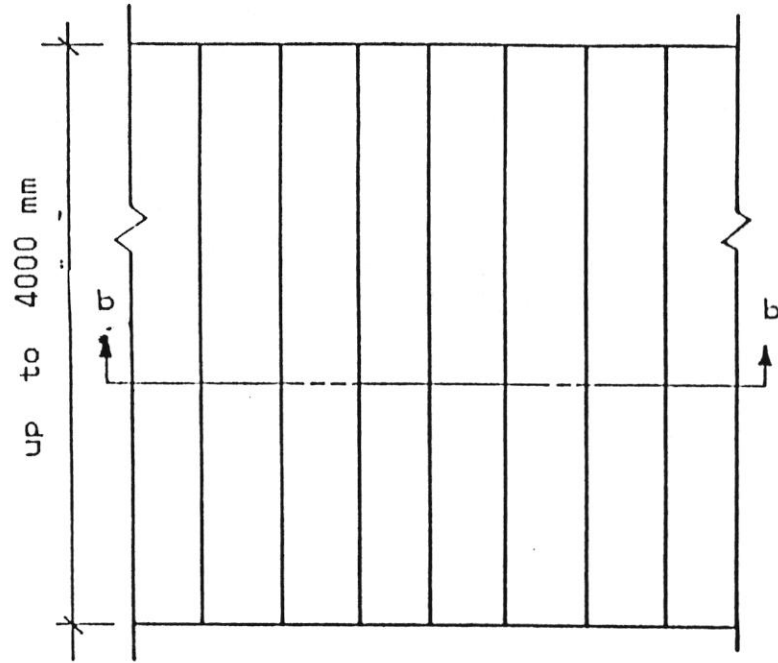
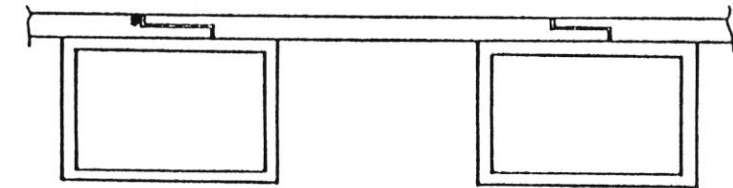
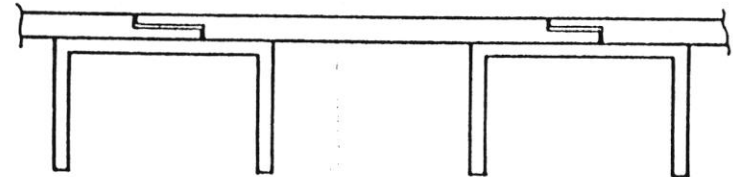
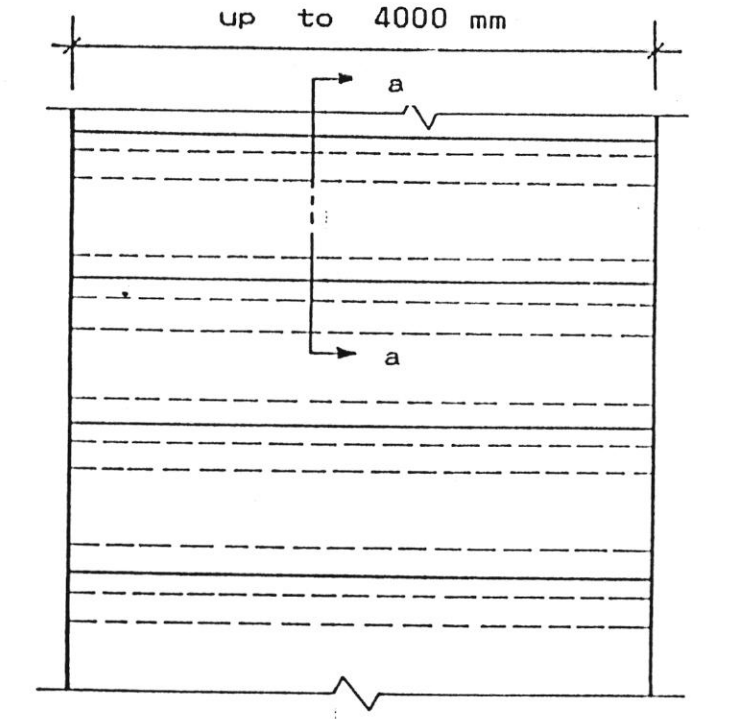

Figure (1) Standardized dimensions of beams, column/wall unit, composite column and shell roof unit.



Section b-b



Section a-a

Figure (2) Panel system for roofing

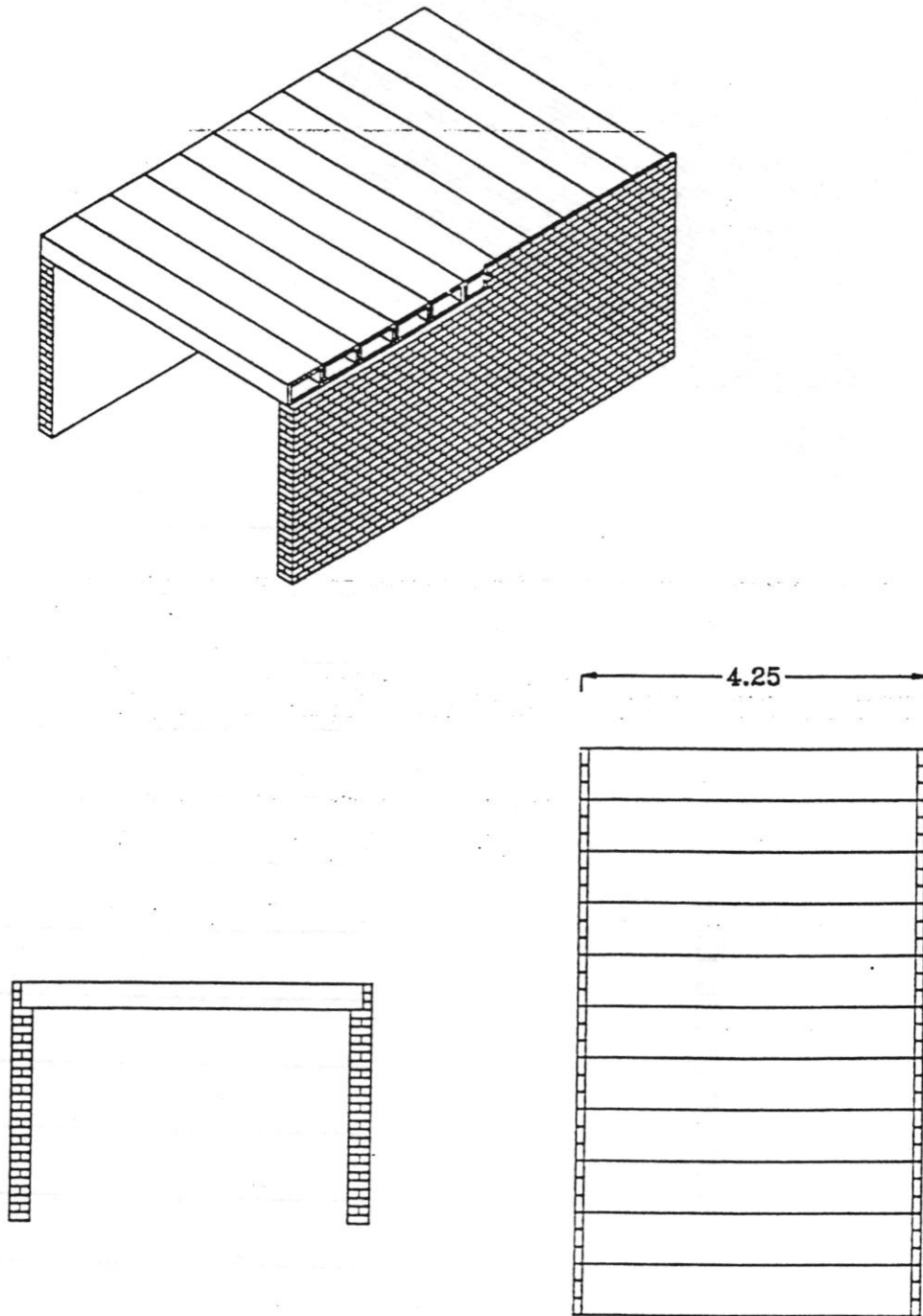

Figure (3) Ferrocement beams for roofing

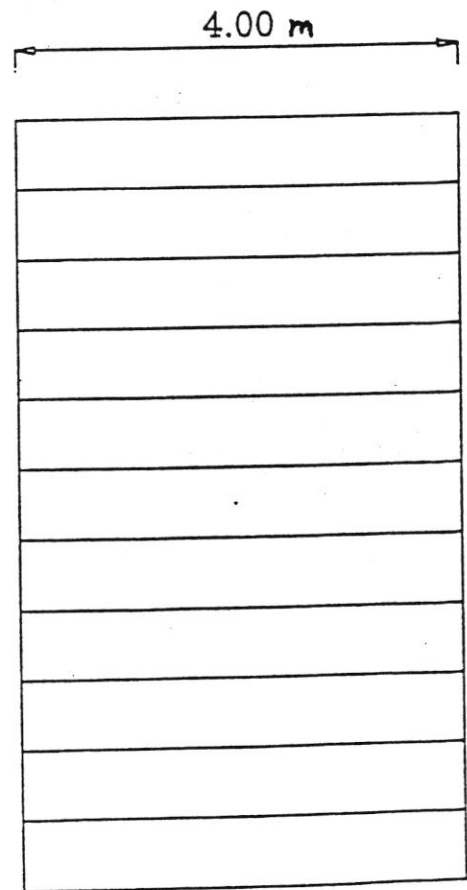
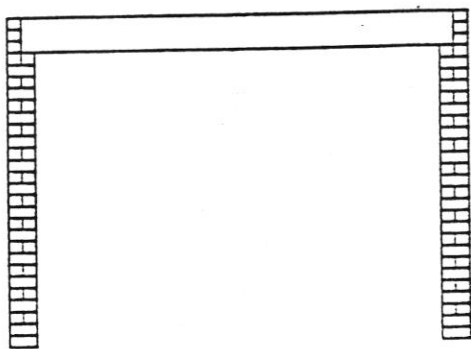
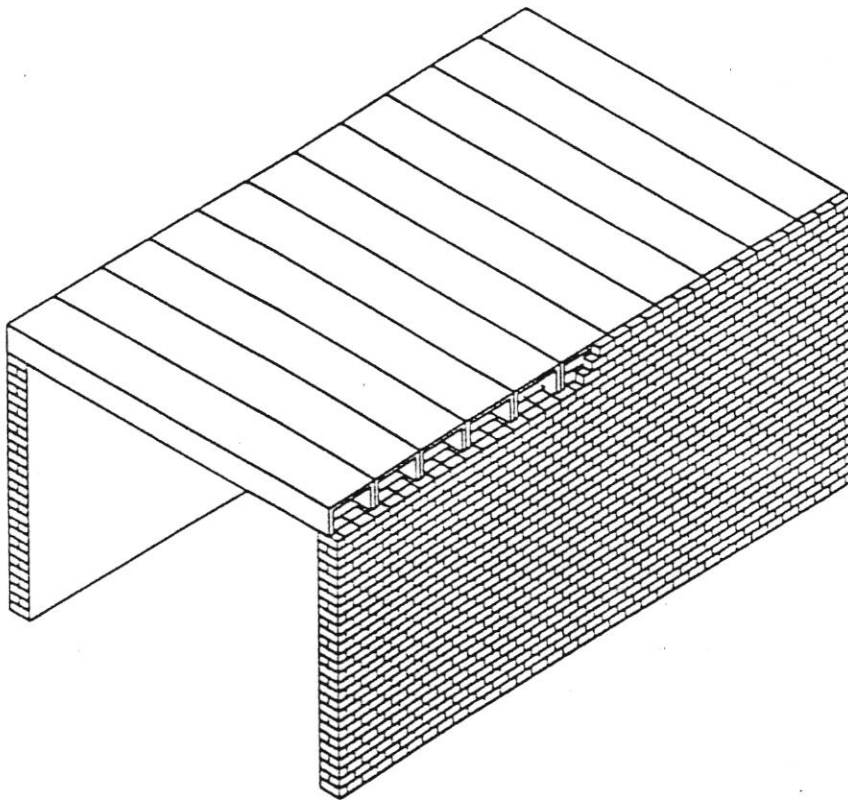

Figure (3) Cont.



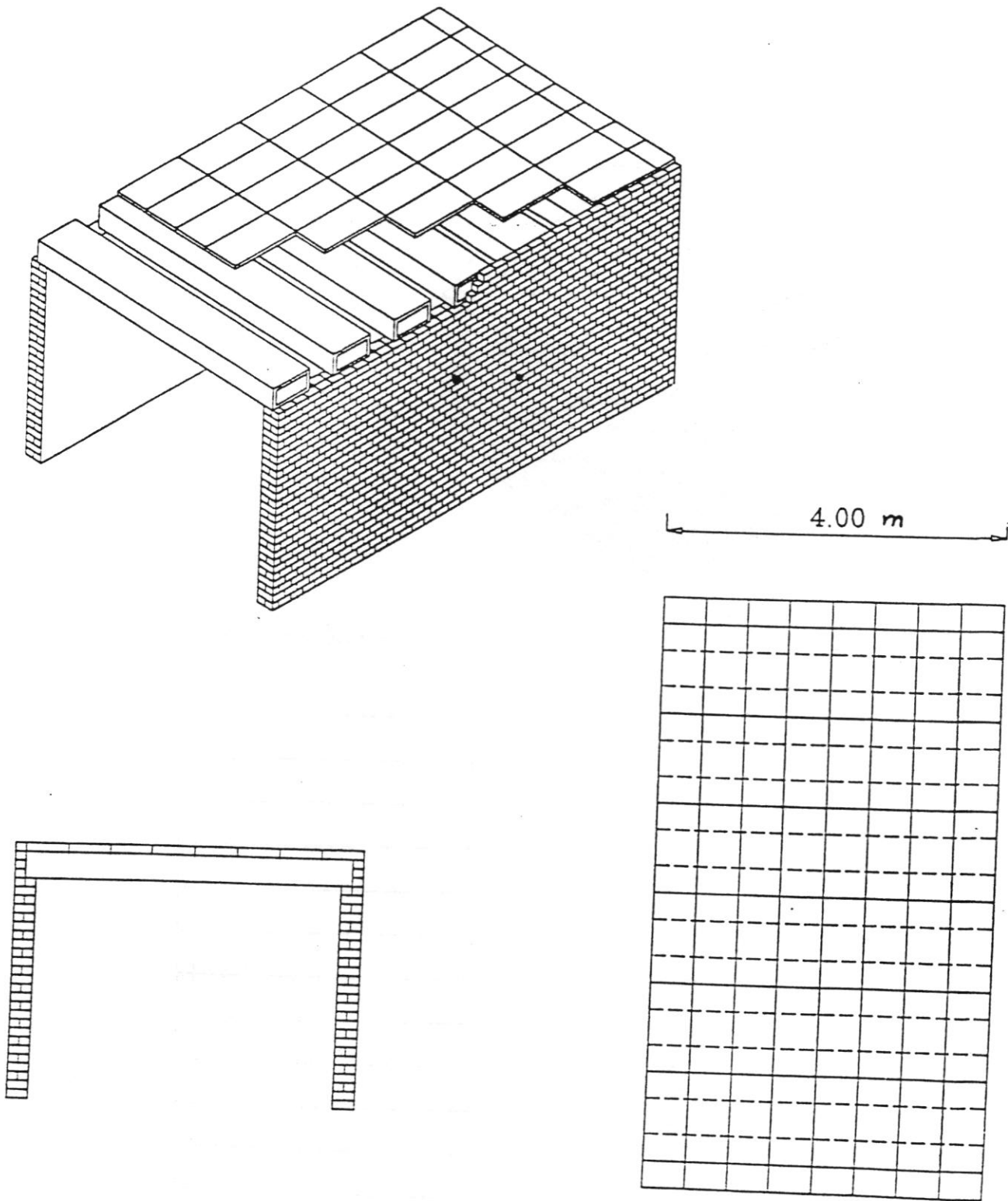
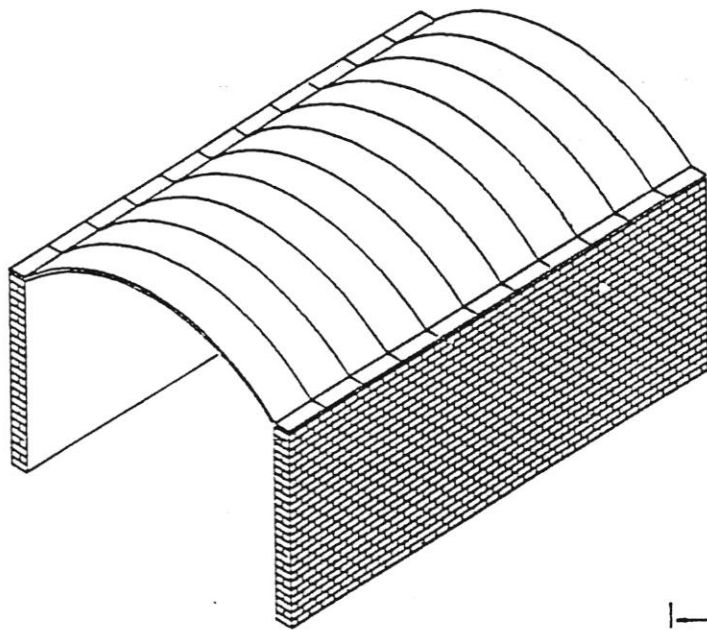

Figure (3) Cont.



4.00 m

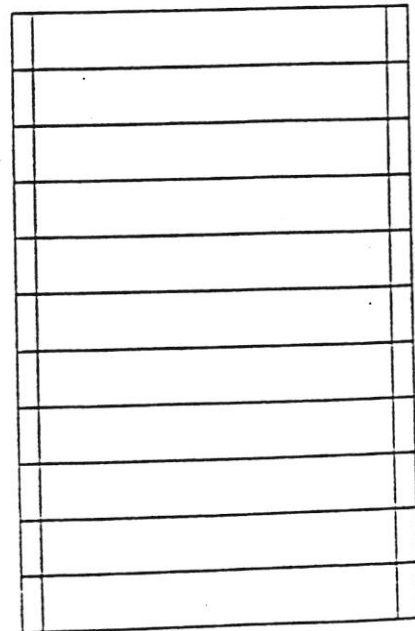
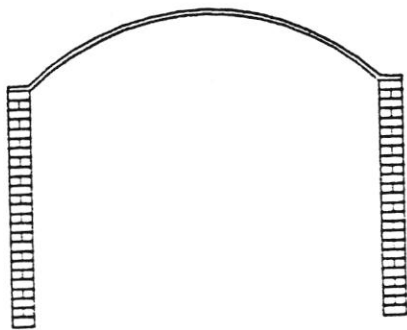

Figure (3) Cont.

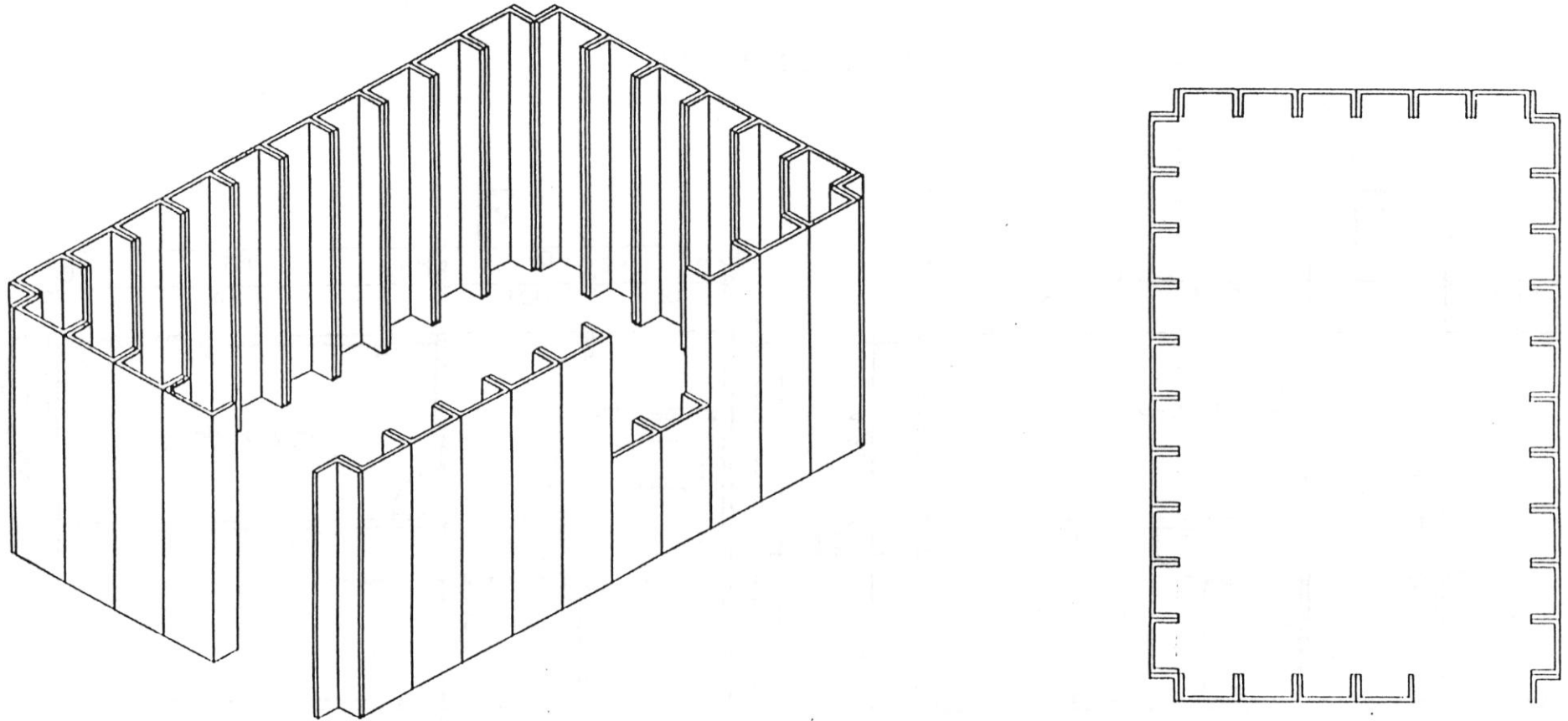

Figure (4) Load-Bearing walls

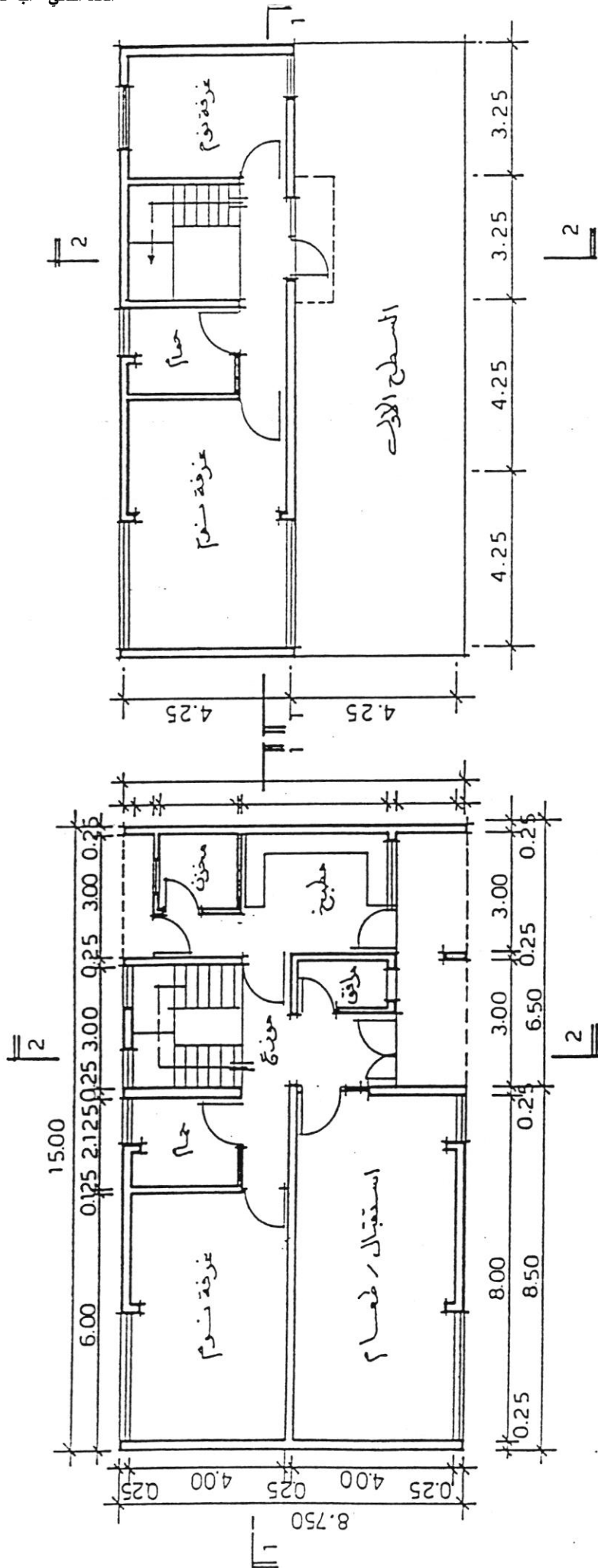

Figure (5) A typical house

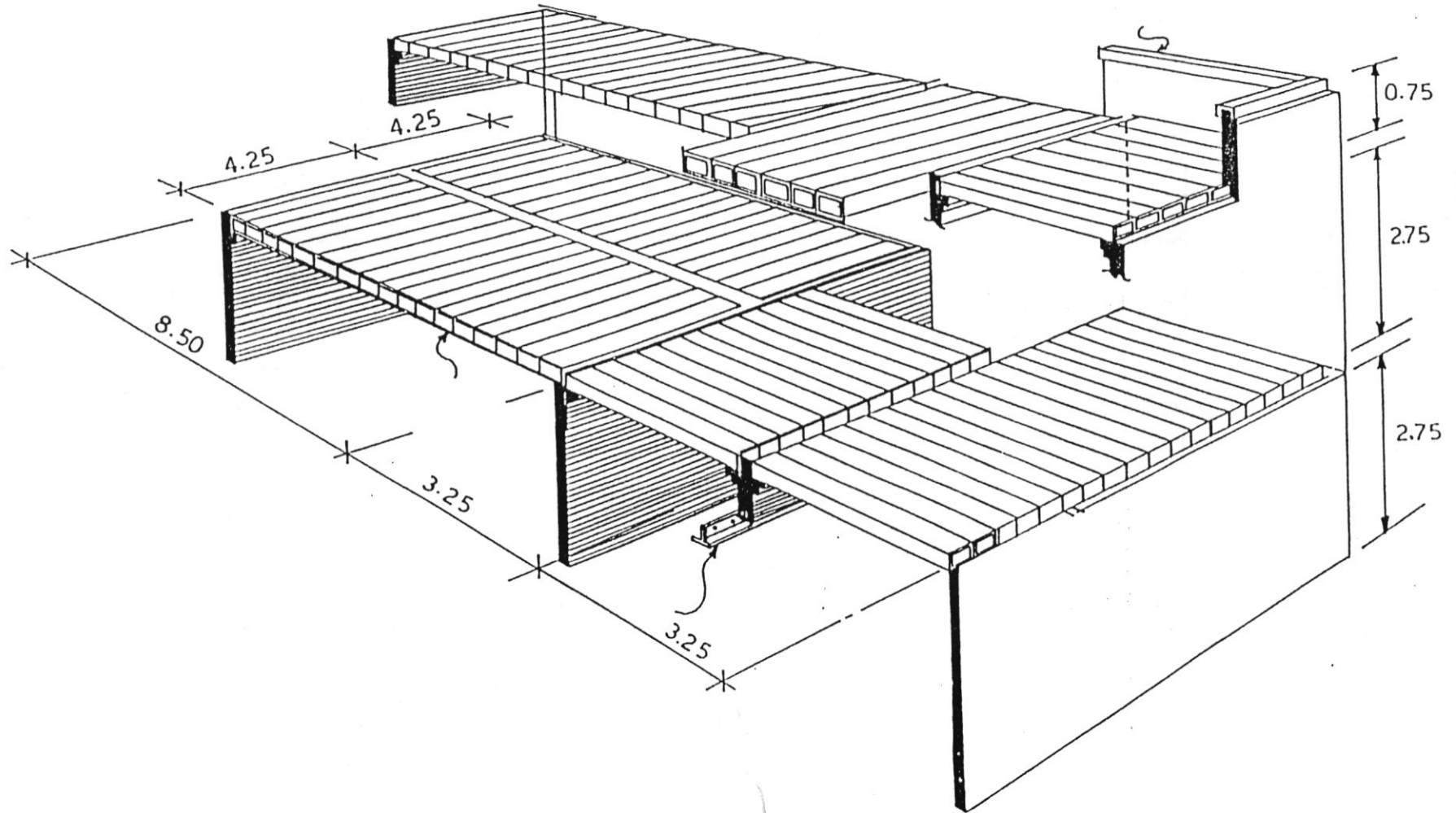

Figure (5) Cont.  
Panel System for Roofing.

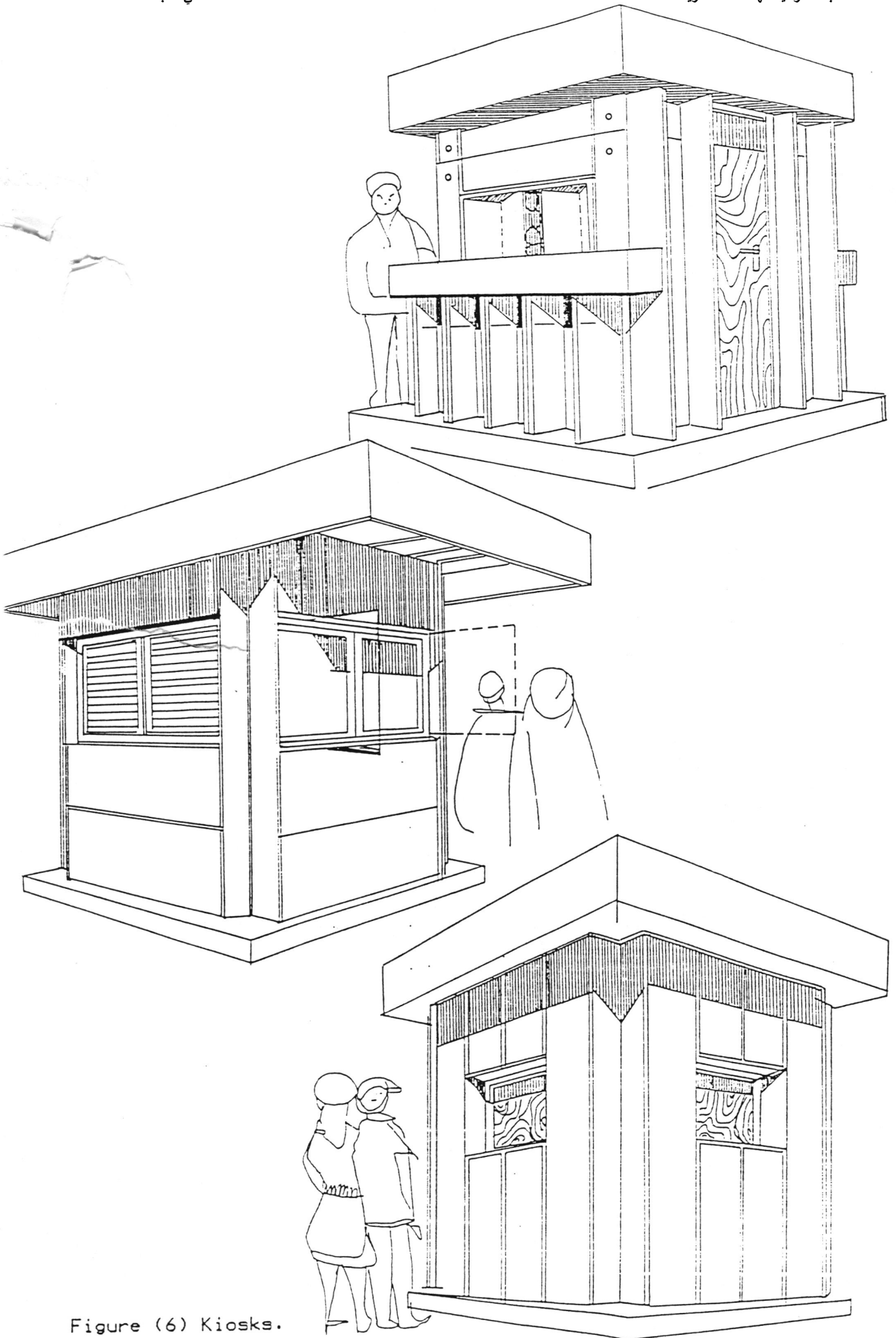

Figure (6) Kiosks.

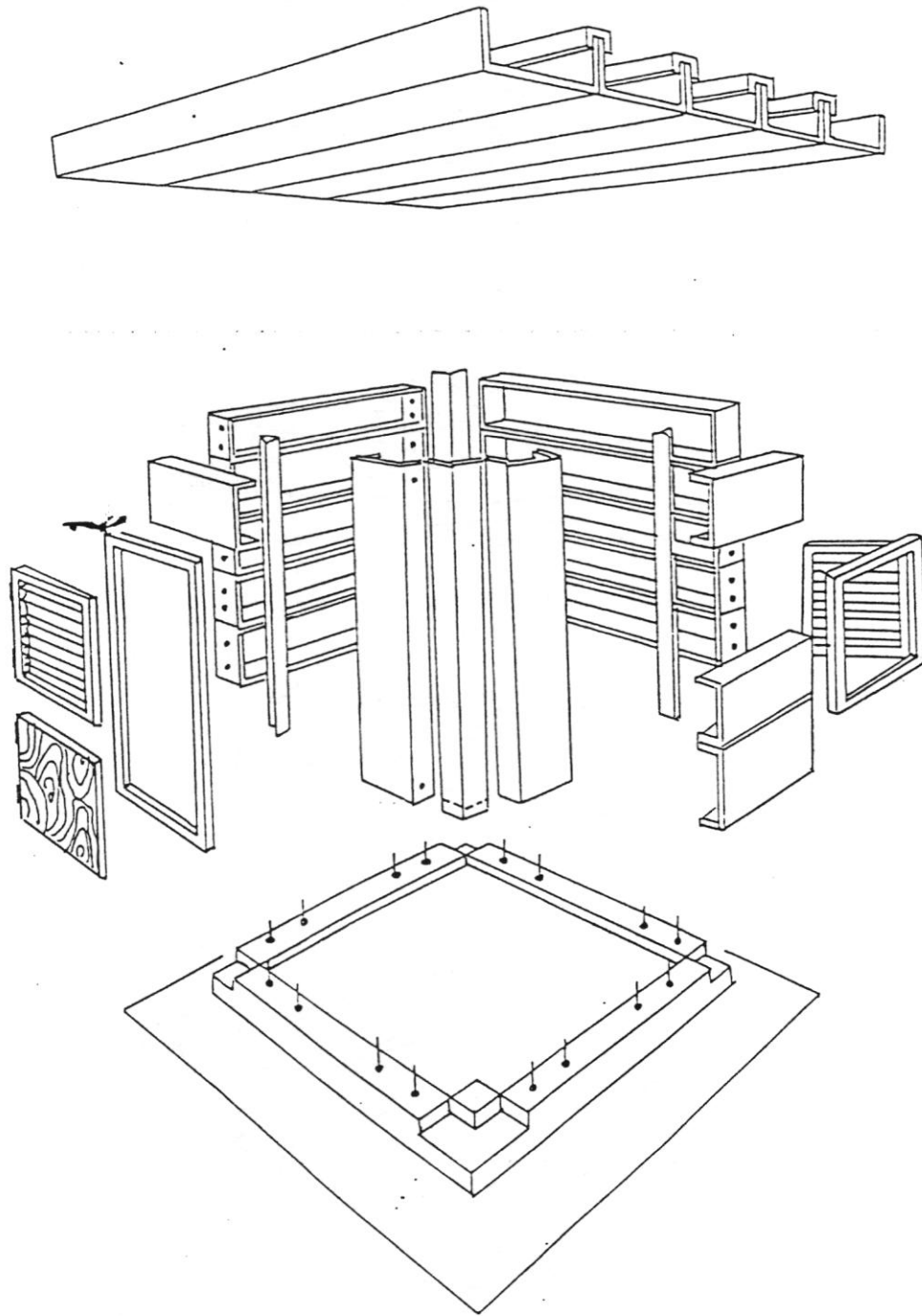

Figure (7) Steps of the Installing the Structural Members During the Construction of a Kiosk.

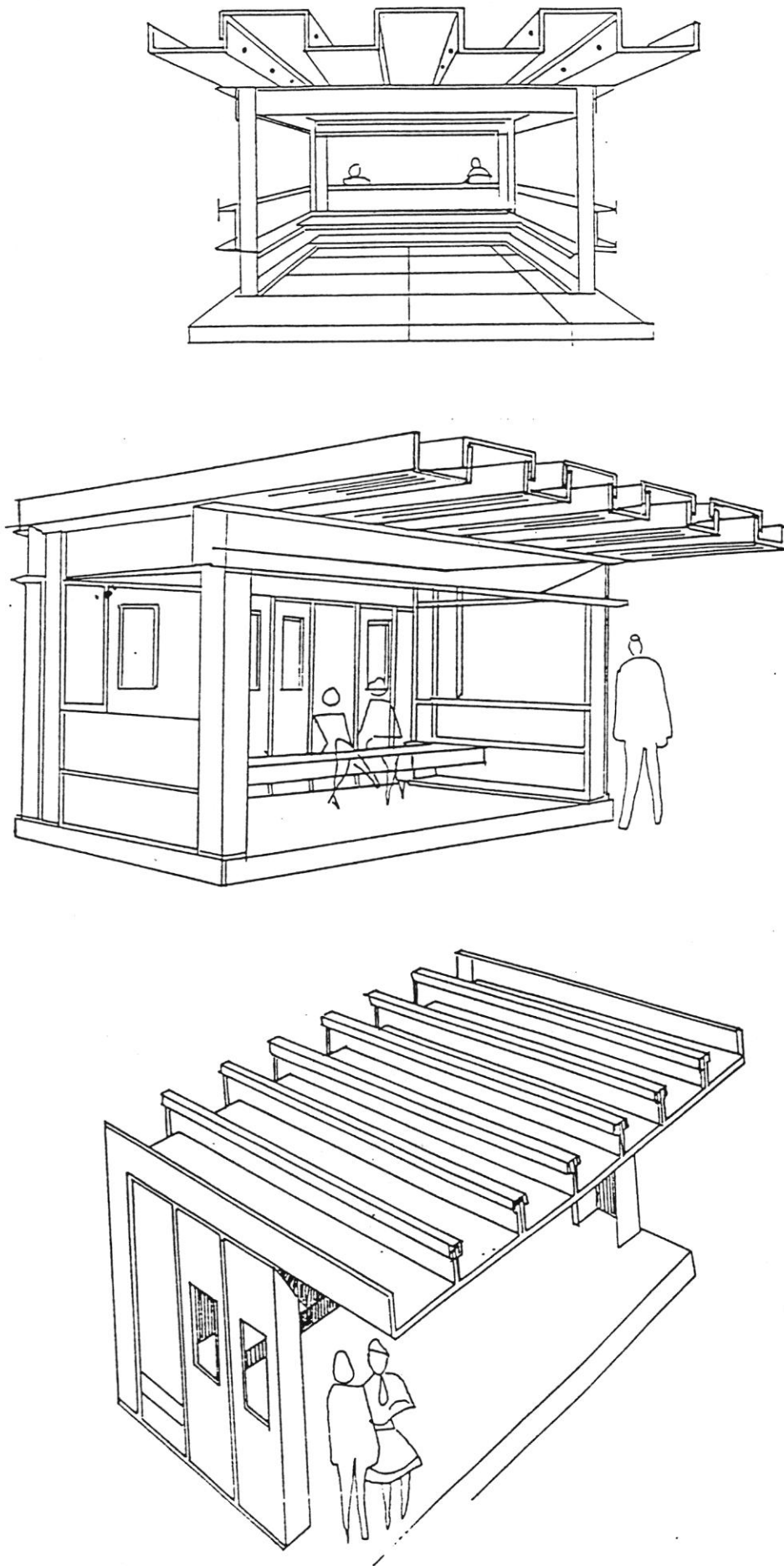

Figure (8) Bus Stop Sheds 117



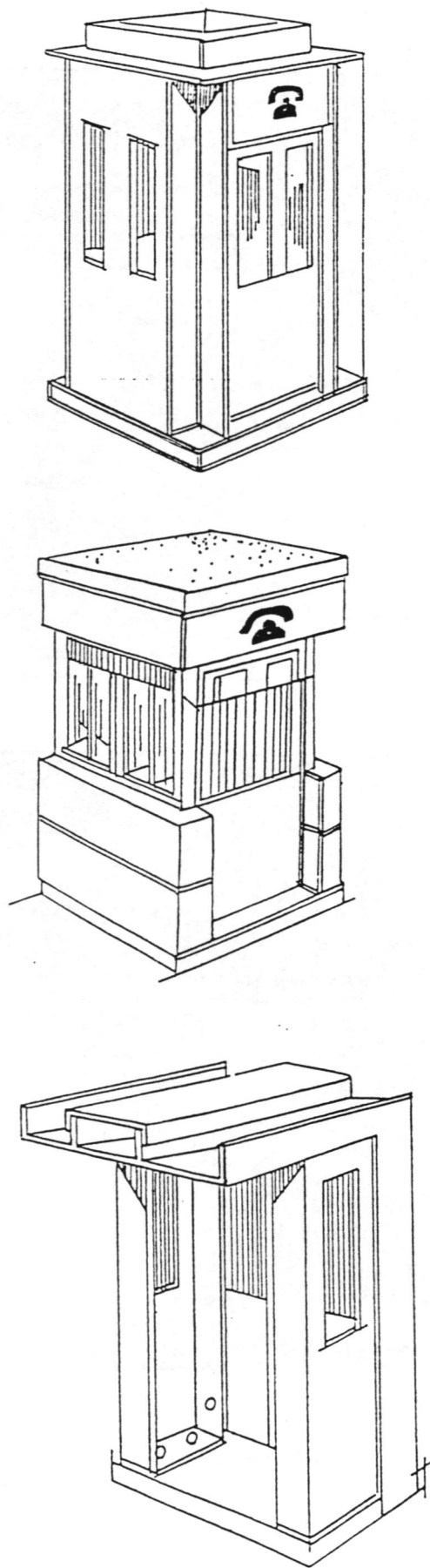

Figure (9) Public Telephone Boxes

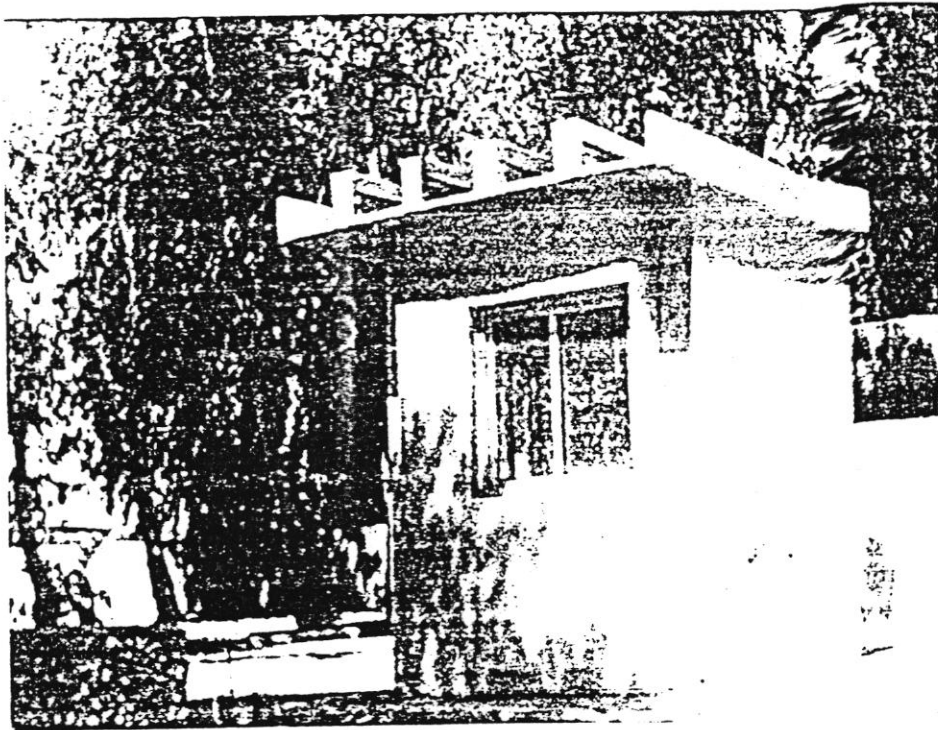
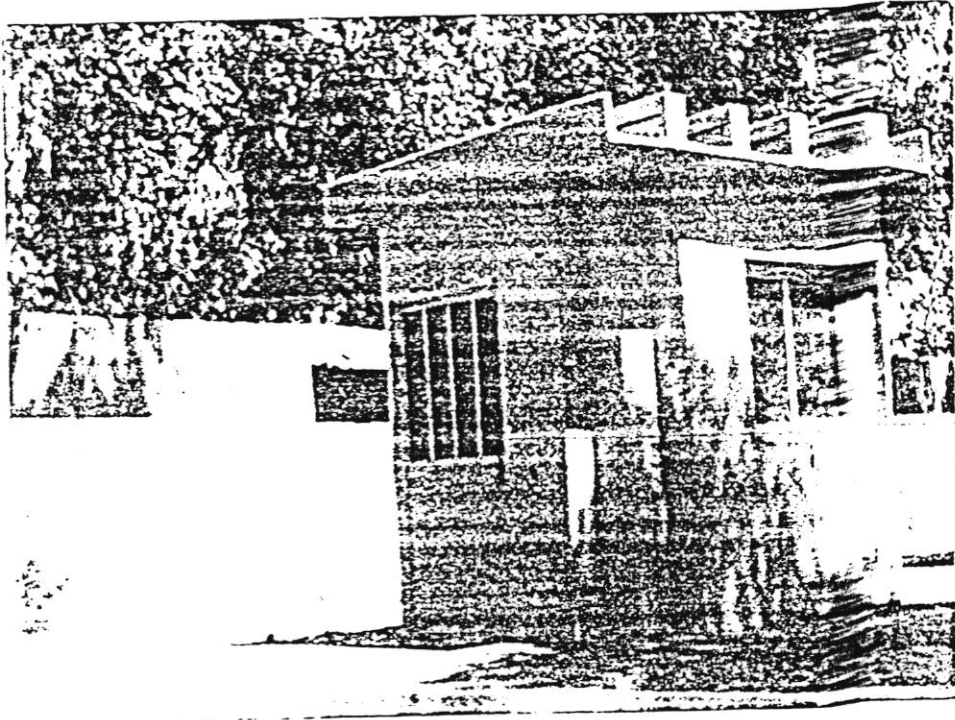

Plate (1)